

CC200 Case Controller

TABLE OF CONTENTS

<ul style="list-style-type: none"> 1. Introduction 3 2. CC200 Overview of Capabilities 3 3. CC200 Hardware Overview 3 4. Expansion Module Overview 4 5. Control Logic Overview 4 <ul style="list-style-type: none"> 5.1. Temperature Regulation 4 5.2. Superheat Regulation 4 5.3. Dual Temperature Cases 4 5.4. Case Lineup Management 5 5.5. Defrost Control 5 <ul style="list-style-type: none"> 5.5.1. Manual Defrost 5 5.5.2. Pump Down 5 5.5.3. Termination 5 5.6. Fan Control 5 <ul style="list-style-type: none"> 5.7.1. Pressure Mode 6 5.7.2. Floating SST Algorithm 6 5.7.3. Sensor Redundancy 6 5.8. Lighting Control 7 5.9. Door Switch 7 5.10. Service Shutdown 7 5.11. Refrigerant Leak Shutdown 7 5.12. Analog Inputs 7 5.13. Digital Inputs 8 5.14. Relay Outputs 9 5.15. Alarms 9 <ul style="list-style-type: none"> 5.15.1. Analog Input Alarms 9 5.15.2. Fan Proof Alarm 9 5.15.3. Defrost Proof Alarm 9 5.15.4. Case Temperature Alarm 9 5.15.5. Communication Offline Alarms 10 5.15.6. Refrigerant Leak Alarm 10 	<ul style="list-style-type: none"> 6. CC200 Display 11 <ul style="list-style-type: none"> 6.1. Display Overview 11 6.2. Unlock and Parameter edits 11 6.3. Action Icons 12 6.4. Status Icons 13 7. The BACnet Network 13 <ul style="list-style-type: none"> 7.1. BACnet MS/TP 14 7.2. BACnet Settings on CC200 Case Display 14 8. E2 Setup 16 <ul style="list-style-type: none"> 8.1. Network Ports and BACnet Settings 16 8.2. Configure E2E BACnet Settings 17 8.3. Add and Connect Case Controllers 18 8.4. Commissioning the Device in E2E 18 9. Cold Chain Connect™ Mobile Application... 20 10. Configuring CC200 Parameters 32 11. Technical Specs and Part Numbers 45 <ul style="list-style-type: none"> 11.1. CC200 Case Controller Specs 45 11.2. CC200 Power Supply Specifications 46 11.3. Expansion Module Specifications 46 11.4. CC200 Case Display Specifications 46 11.5. Part Numbers for Ordering 47 12. CC200 Installing the Update Package 48 <ul style="list-style-type: none"> 12.1. CC200 Application 48 12.2. CC200 PIC Firmware 49 Appendix A: CC200 Case Controller Hardware and Wiring Quick Start Guide 50 Appendix B: CC200 Parameters 66
---	---



FIGURES

<ul style="list-style-type: none"> Figure 1 Controller Image 76 Figure 2 Case Display Overview 76 Figure 3 CC200 Wiring and Connections 77 	<ul style="list-style-type: none"> Figure 4 Network Topology Overview 78 Figure 5 RS485 BACnet MSTP Network Wiring 78
---	---

TABLES

<ul style="list-style-type: none"> Table 1 CC200 Hardware Platform Parts 78 Table 2 Expansion Module Hardware Platform Parts 80 	<ul style="list-style-type: none"> Table 3 Case Display Icons and Description 80
---	---

Instructions Pertaining to Risk of Electrical Shock, Fire, or Injury to Persons

	<p>PLEASE READ BEFORE USING THIS MANUAL</p> <ul style="list-style-type: none"> • This manual is part of the product and should be kept near the instrument for easy and quick reference. • The instrument shall not be used for purposes different from those described hereunder. It cannot be used as a safety device. • Check the application limits before proceeding. • Emerson reserves the right to change the composition of its products, even without notice, ensuring the same and unchanged functionality.
	<p>SAFETY PRECAUTIONS</p> <ul style="list-style-type: none"> • Verify that the supply voltage is correct before connecting the instrument. • Do not expose the gateway to water or moisture: use the devices only within the operating limits avoiding sudden temperature changes with high atmospheric humidity to prevent formation of condensation. • Warning: disconnect all electrical connections before any kind of maintenance. • Fit the transmitter where it is accessible by the End User for troubleshooting and replacement. The instrument must not be opened. • In case of failure or faulty operation send the instrument back to the distributor or to “Emerson” (see address) with a detailed description of the fault.



1. Introduction

The Case Controller 200 (CC200) is a microprocessor-based controller for use in controlling temperature and Superheat in refrigerated fixtures and walk-in boxes. The controller is suitable for medium and low temperature applications and can control all loads in a refrigerated box or fixture for up to three evaporator coils. These include lighting, fans, defrost heaters, solenoid valves, stepper valves, and pulse width modulation valves. The CC200 control system consists of at least one CC200, and one CC200 Case Display and optionally up to three CC200 Expansion Modules (CEM) depending on the case installation. When more than one case or fixture is used within the refrigeration circuit, the Case Controller can communicate critical information between other peer controllers in the lineup. This peer communication allows CC200 to efficiently coordinate defrost, monitor temperatures, collect data, and offer sensor redundancy to keep the system running at all times. The controller can be integrated into a supervisory controller and is currently integrated into the Emerson E2E supervisory controller using BACnet. While integrated with E2E, the CC200 runs completely stand-alone and requires no supervisory controller instructions or commands..

2. CC200 Overview of Capabilities

- Seamless coordination of refrigeration case lineups with support for up to 8 cases in a lineup
- Manages all loads in a refrigerated case: lighting, fans, defrost heaters, LLSV, expansion valve, EEPR.
- EEPR control based on air temperature or suction pressure
- Precise control of evaporator superheat using Stepper EEV or PWM EEV.
- Patent pending floating evaporator SST setpoint management automatically adjusts evaporator SST to the optimum setpoint for discharge air
- Modular design allows up to three (3) evaporator coils per case
- Low, medium, and dual temperature case types.
- Built-in sensor redundancy algorithms keep the system running
- Single power supply for CC200. Expansion modules and display simplify wiring and reduce labor cost
- Form C relays allow direct control of case loads and allow simplified wiring
- Bluetooth connectivity for easy controller status and service
- Communicates with a Supervisory controller via BACnet or Modbus

3. CC200 Hardware Overview

CC200 is built with the necessary onboard IO to perform precise control of a refrigerated case or walk in a box in many different system configurations

- One Triac for control of PWM (pulse width modulation) EEV valve or one stepper motor control for EEPR stepper or EEV stepper
- Five form C relays for controlling fan, defrost, lights and LLSV
 - Fan relay utilizes onboard amperage monitoring for low amperage ECM fan motors
- Two RS485 ports for integration to Supervisor Controllers
- Two RJ45 ports for BACnet IP daisy chain network
- Four digital inputs: user-configurable purpose
- Two analog outputs 0-10VDC or 4-20mA: user configurable purpose.
- One pressure input for suction pressure transducer
- Three color-coded temperature inputs for discharge air, return air, defrost termination, plus coil out temperature

- One defrost current transducer input for heater amperage monitoring
- Two auxiliary analog inputs: user-configurable purpose
- Expansion port connector for easily adding additional IO via CC200 Expansion Module

4. Expansion Module Overview

CC200 Expansion module is built with the necessary onboard IO to add additional IO for modular coil case designs or multi evaporator walk-in boxes

- One TRIAC for control of PWM (pulse width modulation) EEV valve or one stepper motor control for EEPR stepper or EEV stepper
- One digital input: user-configurable purposes
- One pressure input for suction pressure transducer
- Three color-coded temperature inputs for discharge air, return air, and defrost termination plus coil out temperature
- Expansion port connector for easy connection to CC200 Main controller or an additional Expansion module

5. Control Logic Overview

5.1. Temperature Regulation

CC200 precisely controls air temperature to setpoint using either the discharge air or return air sensor as the control sensor. For multi-coil cases with more than one air temperature, a combination method is applied to calculate the final control value. The primary method of regulating air temperature is by regulating an Electric Evaporator Pressure Regulator valve (EEPR) to bring air temperature to setpoint. The EEPR can also be put in a pressure-based control mode where air temperature is still regulated to setpoint. For systems that have a liquid line solenoid (LLSV) installed, the parameter selection **LLSV Present** must be set to **On**. For systems requiring a cut in/cut out method on the liquid line solenoid (LLSV), the parameter **Continuous Refr** can be set to **No**. Setting Continuous Refr to Yes will disable

LLSV cycling when air temperature is below the cut-out band.

5.2. Superheat Regulation

CC200 precisely controls evaporator superheat (SH) for up to three coils in a single refrigerated case or walk-in box. When the **expansion valve type** parameter is set to PWM EEV or Stepper EEV, the CC200 will begin regulating superheat by positioning the selected valve type. The superheat is measured using the coil outlet sensor and a dew point temperature conversion of the connected Emerson pressure transducer. The refrigerant type selection is made with the parameter **Refrigerant** in the System Setup group. The algorithm uses one superheat setpoint for all three coils if present. The superheat is regulated to the superheat setpoint with a +/- half dead band zone, the parameters superheat setpoint and superheat deadband can be found in the setpoints group.

For multi-coil refrigerated case designs, CC200 supports pressure transducer installations of one transducer per coil, or one per case. When the pressure configuration parameter is set to 1 per case, CC200 will use the single pressure value in the superheat calculation for all coils. A coil outlet sensor is required on every coil.

CC200 supports superheat monitoring for TEV systems when the **expansion valve type** parameter is set to TEV SH. In this mode the CC200 uses the connected coil outlet sensor and pressure transducer to monitor the superheat of each evaporator in the case or walk-in box.

5.3. Dual Temperature Cases

Dual temperature cases are supported with separate setpoints for low and medium temperature applications. The CC200 will run in low temperature mode until the dual temperature digital input switch is true. When the dual temperature digital input is true CC200 shifts to run in medium temperature mode, regulating air temperature to the medium temperature setpoint. If there is no digital input configured as dual temperature switch, a network input is used from a supervisor controller. When CC200 detects the network input for



dual temperature is true, the air temperature control is switched to medium temperature mode. EEPR logic automatically shifts between low and medium temperature pressure setpoints when CC200 is in dual temperature mode.

5.4. Case Lineup Management

When refrigerated cases are piped in a circuit and share common liquid and suction piping a lineup is present, CC200 supports peer to peer communication with up to 8 cases in a single lineup (1 master and 7 slaves). The onboard ETH1 and ETH2 RJ45 ports and case to case Ethernet daisy chain wiring provides the connection for this communication to take place. CC200 case lineup communication involves one case designated as the lineup master and all other cases are lineup slaves. CC200 lineup communication allows the controller to seamlessly coordinate defrost, gather temperature data and use sensor redundancy strategies to keep the system running longer in case of control sensor failures. Typically, in a supermarket refrigeration system cases in a lineup defrost at the same time, CC200 case lineup communication is used to coordinate this task efficiently. Configuration of the lineup is performed automatically when the rack ID, lineup ID, case ID and number of cases in lineup parameters are set. The case designated with case ID “a” will automatically detect its peers in the lineup for communication.

5.5. Defrost Control

CC200 supports electric and off cycle defrost types and manages the entire defrost cycle with no control from a supervisory controller required. The onboard form C defrost relay can be used to switch a defrost heater for electric defrost types. Defrost heater amperage can be monitored using the Def CT analog input and a connected CT. A defrost cycle can begin via scheduled start time or through a manual defrost command. The defrost schedule uses a start time and number of cycles parameter, the defrost cycles are spaced evenly through a 24-hour period based on these two parameters. For example: with a start time of 0:00 and 4 cycles per day, the CC200 would enter defrost at 0:00, 6:00, 12:00 and 18:00.

5.5.1. Manual Defrost

Manual and emergency defrost cycles for service purposes are provided, a manual or emergency defrost can be started from the supervisor controller, the case display or the CC200 Cold Chain Connect mobile app. A manual defrost puts CC200 into a defrost cycle that will terminate normally as a scheduled defrost would. An Emergency defrost runs the defrost cycle for the maximum time allowed and will not attempt to terminate early on temperature.

5.5.2. Pump Down

An optional evaporator pump down procedure to remove refrigerant from the coil may be configured via parameter settings. If the pump down duration is set to 0, no pump down procedure will be performed. During a pump down procedure the LLSV is closed first while EEV's and EEPR remain open. After the pump down time expires the EEV's and EEPR move to the close position for defrost. If there is no LLSV present the EEV's close at the start of pump down.

5.5.3. Termination

If a case lineup is configured, the defrost and termination of all cases on the lineup is synchronized so that all cases enter defrost at the same time and resume refrigeration at the same time. Cases may terminate their defrost cycle individually but can only resume refrigeration once all cases have terminated or timed out. Once a case in a lineup terminates defrost then the case enters wait mode until all cases on the lineup terminate or timeout.

Termination can be time, temperature or digital input based. No matter which termination method is selected, no case can defrost longer than the maximum time.

5.6. Fan Control

CC200 controls the evaporator fan motor using the onboard form C relay labeled Fan. A variety of fan control logic is supported to accommodate different systems and temperature applications. The fan during refrigeration can be set to cut in/cut out with the air temperature setpoint and dead band or be set to run continuously during refrigeration. During defrost the fan can remain on or off depending on parameter selection



to accommodate different case types. Optionally via parameter selection, the fan can be delayed after defrost to allow moisture on the coil to re-freeze. The fan can be delayed by time or temperature, the default action is time with no delay.

For service and analytics, the CC200 measures the fan motor amperage through the internal form C relay. The case controller is able to measure current for low amperage ECM type motors as well as fixed speed motor designs. The onboard fan relay can control motors up to 5 AAC, motors greater than this rating should be controlled with a pilot relay or contactor. For these larger motors CC200 supports amperage monitoring through AI1 or AI2 with a CT connected.

5.7. Electric Evaporator Pressure Regulator (EEPR)

CC200 can manage an EEPR for regulating air temperature and evaporator pressure. Two control modes are available, discharge air or pressure. In air temperature mode, the valve will be regulated to maintain air temperature to setpoint. In air temperature mode when a case lineup is present, the lineup master will gather all available air sensor values from all CC200's in the lineup. The lineup master will perform a combination method on the available sensors; the combination method is selectable via parameter selection with options of average, minimum and maximum. Any sensors that are in error will be automatically discarded from the combined control value.

5.7.1. Pressure Mode

In pressure mode the suction pressure is converted to a saturated suction temperature (SST) and the valve is regulated to maintain precise SST control to the active SST setpoint. The saturated conversion method is selectable via the parameter with options of: dew point, midpoint, bubble point or a weighted average of 60% dew / 40% bubble. The refrigerant parameter for refrigerant selection determines the refrigerant gas used for SST calculation. For dual temperature cases a low and medium temperature SST setpoint are provided. CC200 will automatically shift between the low and

medium temperature setpoints whenever a dual temperature shift is required.

5.7.2. Floating SST Algorithm

CC200 utilizes a floating saturated suction temperature algorithm to automatically tune the SST to an optimal setpoint for air temperature control. Many refrigerant blends have a high temperature glide, as a result running the evaporator at the design saturated temperature can result in discharge air temperatures that are lower or higher than desired. CC200 deploys an algorithm that makes tiny incremental adjustments to the SST setpoint over time in order to tune discharge air temperatures to the target setpoint. The algorithm constantly analyzes air temperature data to determine if an adjustment is needed. Once air temperature is on target the SST setpoint is saved as the new operational setpoint. To enable the floating algorithm, set the float band parameter to a value greater than 0. A value of 4°F is suggested as a starting value. The float band parameter defines the amount of adjustment allowed above and below the SST setpoint. For example, an SST setpoint of -10° with a float band of 4° will allow the algorithm to adjust the SST setpoint from -12° to -8°.

5.7.3. Sensor Redundancy

In pressure mode the EEPR control logic uses pressure 1 as the input, if pressure 1 is in error the CC200 automatically falls back to pressure 2 if available, then pressure 3. If no local pressure sensors are available and there is a lineup CC200 will search the available pressure sensors from lineup slaves to find a backup sensor for control. Once the primary control input failure is restored, CC200 automatically switches back. If there are no pressure sensors available onboard or throughout the lineup, CC200 will automatically fall back to discharge air mode on the EEPR in order to maintain food safety. If there are no pressure or discharge air sensors available with valid readings, CC200 will position the EEPR at the 24 hour refrigeration average.



5.8. Lighting Control

CC200 supports multiple lighting control options to accommodate different customer lighting strategies. The lights are controlled from the onboard form C relay labeled Light. The control mode is selectable via parameter, the options are DI Triggers, Schedule w/Dimming, Supervisor w/Dimming, Local Schedule Only, Supervisor Control.

When DI Triggers mode is selected the lights will switch on by a motion sensor digital input or a walk-in box door switch. When the digital input is active the lights switch on for a specified amount of time before turning off again. The time delay is adjustable via parameter.

When Schedule w/Dimming is selected the lights will be controlled based on the CC200 schedule on and schedule off parameters. During scheduled off hours the lights will be completely off and will not dim, ramp up or down. During schedule on hours the lights will remain dim until the motion sensor detects movement. Once motion is detected the lights ramp up from minimum dimming level to maximum dimming level. After 5 minutes with no motion detected the lights ramp from maximum dimming level to minimum dimming level and remain there until motion is detected again.

Supervisor w/Dimming deploys the exact same logic as Schedule w/Dimming but instead of the local schedule the supervisor directly controls the light relay with its own schedule. During scheduled on hours dimming is allowed, during scheduled off hours no dimming is allowed.

Supervisor control allows the light relay to be directly controlled by the supervisor controller with no dimming or motion sensor logic. If the supervisor is offline, then CC200 falls back to its local schedule to control the light relay.

5.9. Door Switch

CC200 supports a door switch for walk in box door opening detection. A door switch must be configured on one of the available digital inputs on CC200 or the CC200 expansion module. The door switch can be used to turn refrigeration and fans off during door opening events. This feature is configurable via parameter, when

activated the liquid line solenoid and fan relay outputs will be turned off during door openings. Once the door closes, the relays will become active again; there is a failsafe timeout parameter to return the relays to on. If the door remains open longer than the failsafe time then the fan and LLSV automatically become active again.

The door switch can also be used to switch the lights on, this feature can be enabled/disabled via parameter. When enabled the lights turn on with every door opening for the amount of time defined by a parameter.

5.10. Service Shutdown

For cleaning and service convenience, the CC200 supports a service shutdown feature. This can be activated from the case display, supervisor controller, Cold Chain Connect mobile application or a physical switch. When a service shutdown is active, all relays will immediately turn off and all valves will close, all control logic will be suspended. The default timer for shutdown is 60 minutes, after the timer expires the case resumes refrigeration again.

5.11. Refrigerant Leak Shutdown

CC200 supports a specific refrigeration leak shutdown to disable refrigeration in the event of a refrigeration leak event. The leak shutdown can be triggered by a physical digital input or from a supervisor controller over the communication network. When a leak shutdown is active the system will shutdown and perform a pump down if the pump down time is greater than 0. If a leak shutdown is initiated by a supervisor controller the shutdown will persist through CC200 reboots. The leak shutdown will end once the supervisor controller removes it and the digital input function is inactive (if configured).

5.12. Analog Inputs

CC200 Main Controller has a combination of fixed function and auxiliary analog inputs onboard. The CC200 expansion module has only fixed function inputs. The fixed function inputs are labeled with a name on the controller enclosures and do not have software selectable functions. The engineering unit range of the pressure transducers is selectable via CC200 parameter. The purpose of each fixed function input is described below:

Enclosure Level	Purpose
Pressure 0V, Sig, +5V	Pressure transducer connection, .5-4.5 VDC software selectable EU range 100 PSI, 150 PSI, 200 PSI, 300 PSI.
DAT	Discharge air temperature sensor connection, non-polarity sensitive
Term	Defrost termination temperature sensor connection, non-polarity sensitive
RAT	Return air temperature sensor connection, non-polarity sensitive.
Coil Out	Coil outlet temperature sensor connection, non-polarity sensitive

The CC200 Main Controller has Aux Inputs AI1 and AI2 with software selectable function. Each input has identical options, described in the table below:

Function Option	Purpose
Fan CT	For connection of current transducer for evaporator fan motor amperage monitoring and alarming. Used when fan motor amperage is greater than the 5 amps limit for the onboard CT on the CC200 fan relay.
Coil Inlet	Evaporator coil inlet temperature sensor. Mounted after expansion valve outlet for Coil Out-Coil In superheat calculation
Product Temperature	Product temperature sensor for product temperature monitoring and alarming

Coil Suction Temperature	Circuit suction temperature sensor for overall circuit lineup superheat monitoring and alarming
--------------------------	---

All input sensors have an option to enter a sensor value offset via parameter settings.

5.13. Digital Inputs

The CC200 main controller has four selectable function voltage free (dry contact) digital inputs on terminals 31-38. The CC200 Expansion Module has one selectable function potential free digital input on terminals 10-11. All selectable function digital inputs have the following function options:

Function Option	Purpose
Door Switch	Door switch for walk in box door opening detection.
Service Shutdown	Shutdown switch for service shutdown activation/de-activation.
Dual Temperature	Dual temperature switch for switching dual temperature cases between low and medium setpoints
Defrost Termination	Defrost termination signal, terminates defrost when true
Motion Sensor	Motion sensor for lighting control
Leak Shutdown	Refrigerant leak shutdown, activates/de-activates a leak shutdown
Satellite 1	Satellite 1 for E2E, acts as a spare digital input and reports value to E2E
Satellite 2	Satellite 2 for E2E, acts as a spare digital input and reports value to E2E



Each digital input function has a companion parameter called active state. Active state determines what physical state of the digital input contacts results in a logical true for CC200 control logic.

Example:

Physical Contact	Active State	Logical Result
Close	Close	TRUE/ON
Close	Open	FALSE/OFF
Open	Close	FALSE/OFF
Open	Open	TRUE/ON

5.14. Relay Outputs

The CC200 Main Controller has four fixed-function form C relay outputs and one auxiliary form C relay output with selectable functions. The function of each fixed function relay output is described below:

Enclosure Label	Purpose
FAN/CT	Evaporator fan motor control with internal current transducer for amperage monitoring
DEFROST	Defrost heater control
LIGHT	Case/walk in box lighting control
REFRIG	Refrigeration liquid line solenoid valve (LLSV).

The relay labeled AUX RELAY on the enclosure is an auxiliary and has selectable functions.

All relay functions have an associated active state parameter that determines if the relay should be energized or de-energized to turn on the connected load.

5.15. Alarms

CC200 tracks multiple alarm conditions in the refrigerated case/walk in box. All alarms automatically reset when the condition is resolved, there is no manual reset or manual clearing of active alarms.

5.15.1. Analog Input Alarms

All analog input sensors have a sensor failure alarm to indicate a sensor failure. Sensor alarms will automatically be reset once the sensor reading is valid again.

5.15.2. Fan Proof Alarm

The fan motor current transducer (internal and auxiliary AI function) can be used to monitor and determine a fan motor status. When fan relay is on and the amperage from the fan CT rises above the fan on setpoint the fan motor status is considered ON. If the amperage falls below the on setpoint while the relay is on, the status will turn off and a fan motor command failure alarm will result. When the fan relay is off and the amperage from the fan CT falls below the off setpoint, the fan motor status will be considered off. If the fan motor status becomes on while the relay is off, a fan motor command failure alarm will result.

5.15.3. Defrost Proof Alarm

When a defrost CT is configured on one of the available CC200 auxiliary AI's the defrost amperage monitoring and alarming feature can be used. When the defrost relay is on and the amperage from the defrost CT rises above the defrost on setpoint, the defrost status is considered ON. If the amperage falls below the on setpoint while the relay is on, the status will turn off and a defrost heater command failure alarm will result. When the defrost relay is off and the amperage from the defrost CT falls below the off setpoint, the defrost heater status will be considered off. If the defrost heater status comes on while the relay is off, a defrost heater command failure alarm will result.

5.15.4. Case Temperature Alarm

Case temperature alarm logic will monitor case air temperature during the refrigeration cycle to determine if there is a high or low alarm. If the air temperature in the case rises above the high case temperature setpoint or falls below the low case temperature setpoint for longer than the alarm delay, then an alarm will result. The high case temperature alarming is disabled following a defrost for the duration of the delay after defrost parameter.

5.15.5. Communication Offline Alarms

Each CC200 expansion module that is configured will have an alarm condition if communication fails. The alarm will automatically reset once communication is successful again.

If a lineup is present the lineup master (designated by case ID “a”) will monitor each of its configured slaves for communication, if any slave falls offline the master will generate a slave offline alarm. The alarm will reset once successful communication is restored.

The lineup slaves will monitor communication from the lineup master and if an offline condition is detected a master offline alarm will result. The alarm will reset once successful communication is restored.

CC200 will monitor communication from the supervisor controller (if connected), if communication fails for more than two minutes a supervisor offline alarm will result. The alarm will reset once successful communication is restored.

5.15.6. Refrigerant Leak Alarm

When it is detected that there is a refrigerant leak, the CC200 will immediately shut down refrigeration with no delays. During this time, a Pump Down Procedure will occur to remove refrigerant from the coils and minimize the amount of refrigerant that can leak. This alarm will reset when the source of the refrigerant leak detection has been resolved. This alarm will persist through reboots until it is resolved.

6. CC200 Display

6.1. Display Overview

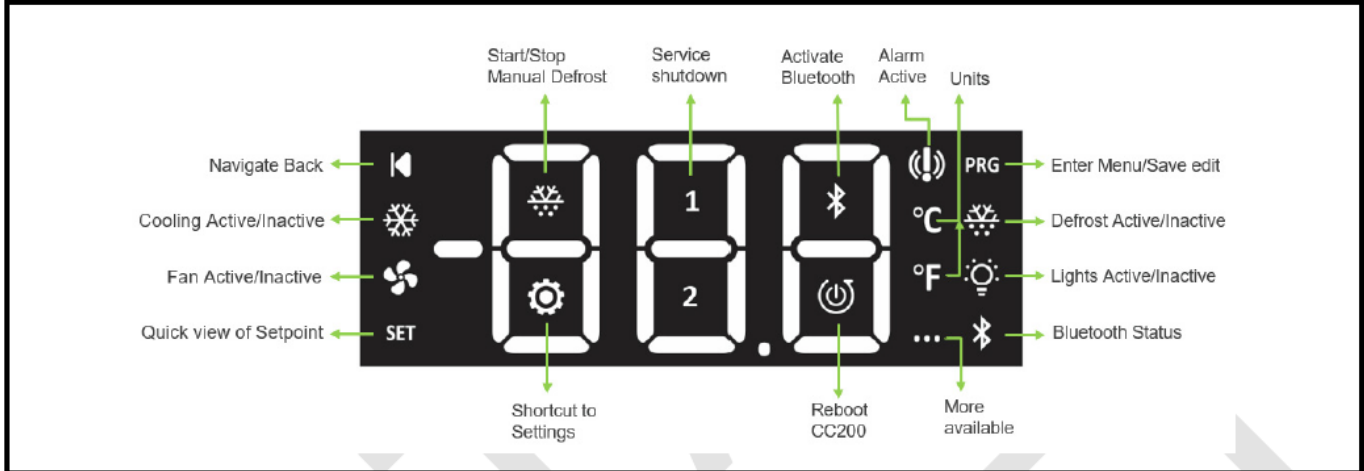

The CC200 case display is the local user interface for the CC200 case controller. The display is connected to the CC200 main controller for supply power and communication. Status information, parameters, and service actions are available through the display. Bluetooth connectivity can be activated using a quick action icon on the display.

When the display is locked the main temperature, screen is visible with the air temperature and unit of measure indicated. The air temperature displayed is the average of the connected discharge air or return air sensors depending on the type of control sensor selected.

The display will show the letters DEF in place of the temperature immediately following a defrost until the temperature has pulled back to down near the air temperature target.

The display will show the letters OFF in place of the temperature if there is a service or leak shutdown active from any source (Supervisor controller, display action icon, Cold Chain Connect mobile app or digital input). OFF will be shown for the entire duration of the service shutdown.

6.2. Unlock and Parameter edits

Unlock the display: Push and hold the upper right corner for 5 seconds and the display will beep and **PRG** and **SET** will become visible.

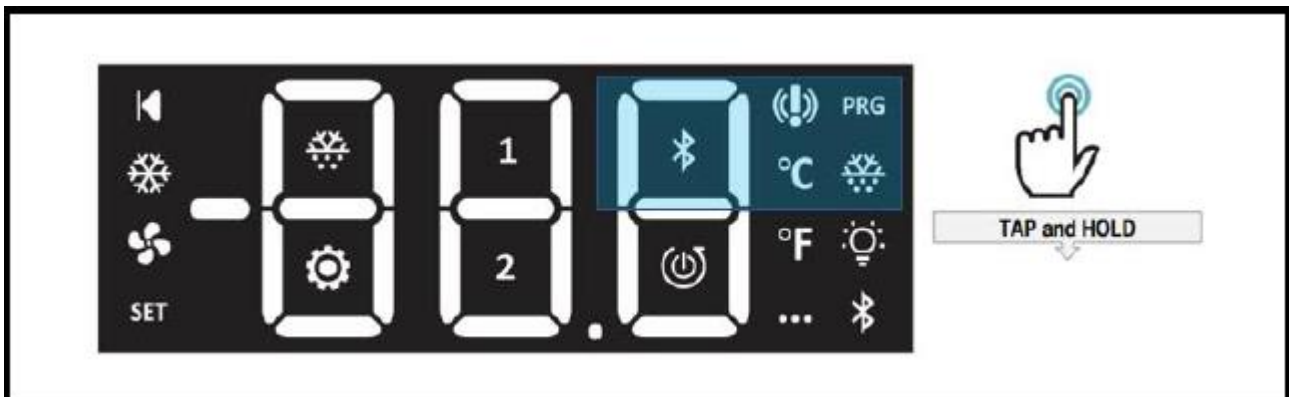

Once unlocked, from the main temperature screen touch and hold **PRG** for 3 seconds to reach the parameter menu. **BAC** will be displayed for the BACnet settings group.



Tap **BAC** to enter the parameter group, **ADR** will be shown, the first parameter in the group.

The following parameters are available for edit. Horizontal swipe to browse each.

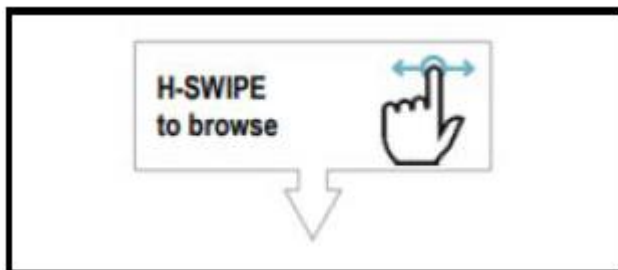

ADR	Enter the BACnet MS/TP mac of the controller
BAU	Select the MS/TP baud rate for the BACnet (router)
RID	Select the rack system ID for the case
LID	Select the lineup circuit number
CID	Select the case letter ID
NAS	Enter the BACnet max master of the controller
APR	Enter the number of application protocol data unit retries

APT	Enter application protocol data unit timeout
NIF	Enter max frames to send per token
RTR	Select yes if the controller is MS/TP to IP router
SAV	Command to saves the current edits to BACnet settings

Example: Swipe horizontally to reach **BAU**, tap **PRG** to see the current value. Swipe up/down to edit the value.

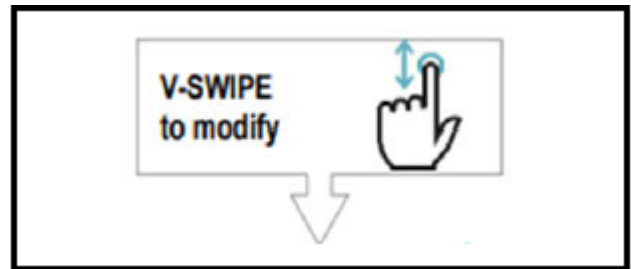

Hold **PRG** for 3 seconds to save the new value and exit. The display will beep and blink at completion of save.

The other parameter group besides **BAC** is **VER**. There are two parameters inside the group **VER**:



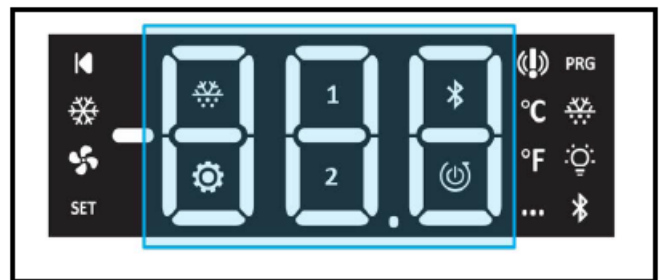

UPd	Initiate the display firmware file upgrade from CC200, set yes to begin
Otp	Enter OTAP mode for over the air upgrade from Mobile App, set yes to begin

6.3. Action Icons



The six action icons in the center of the display are described in the following table. All of the action icons can be reached once the display is unlocked.





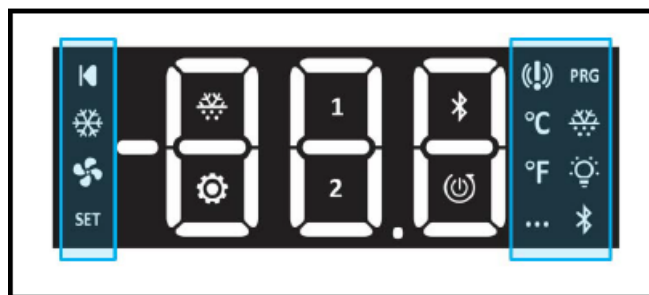

Unlock the keyboard and horizontal swipe to reach the actions.

Icon	Requirement
	When no defrost is active long press for 3 seconds to start manual defrost. During a defrost long press for 3 seconds to end manual defrost.
1	Long press for 3 seconds to enter service shutdown. Long press again for 3 seconds to exit service shutdown.
	Long press for 3 seconds to turn on Bluetooth radio. Long press again for 3 seconds to turn off Bluetooth radio.
	Long press for 3 seconds to jump to parameter group "BAC"
2	No function
	Long press for 5 seconds to reboot CC200

6.4. Status Icons

The 12 icons on the outer edge of the display are described in the following table:



Icon	Description
	Tap to navigate back
	Solid on if refrigeration cooling is active, off if inactive
	Solid on if fan active
SET	Solid on when display is unlocked. Tap for quick access to view active air setpoint.
	Solid on when at least one alarm is active.
°C	Celsius temperature unit label.
°F	Fahrenheit temperature unit label.
...	Solid on when there are more pages/screens available to access by swiping.
PRG	Solid on when display is unlocked. Hold for 3 seconds to enter menu or save an edit.
	Solid on indicates defrost is active
	Blink when light output is ON
	Blink 1 second on/off if BLE is active and ready to pair

7. The BACNet Network

The CC200 operates as a standalone controller, but also can be connected to a Supervisory controller as well for remote access, setpoint configuration and alarming. The CC200 comes equipped with BACnet MS/TP and BACnet over IP communications. For communication with a Supervisory controller the Case Controller uses a BACnet MS/TP to BACnet IP router topology. A single CC200 in each network will connect to the supervisor via BACnet MS/TP, this case controller

will be designated as the router and will act as an RS-485 to Ethernet router. The router routes all traffic between the 485 and Ethernet networks. From the router all other devices that must communicate with the supervisor will daisy chain off of the router ETH1 and ETH2 ports. Configuring the CC200 as a router is covered in [Section 7.2., Configuring BACnet Settings on the CC200 Case Display](#) of this manual. [Figure 4](#) gives an overview of the network topology.

7.1. BACnet MS/TP

The CC200 designated as the router device will connect to the supervisor controller via RS-485 wiring. Emerson specs General Cable 92454A (Emerson P/N 135-0600) shielded twisted pair cables for use as BACnet MS/TP RS-485 wiring. [Figure 5](#) shows the connection detail between the CC200 router RS485 port and the E2E RS485 port.

- **RS485 Cable Type Requirement:** Shielded Twisted Pair 22 AWG Emerson P/N 135-0600.
- **RS485 Cable Specs:**
 - Capacitance Between Signal Wires: 30pf/ft (100pf/m) or Less.
 - Capacitance Between Signal and Shield: 60pf/ft (200pf/m) or Less.
 - Nominal Impedance: 100 to 300 Ohms.
- **RS485 Network Guidelines:**
 - Maximum Daisy Chain Cable Distance: 3000ft at 19200 Baud with Maximum of 32 Devices.
 - Termination at E2E: If E2E is a network end point then terminate at E2E using serial port jumpers – To terminate, set all three (3) Jumpers to the MOD position. Terminate the other end point of the network using CC200 RS485 Term Switch or 150 Ohms.
- **Shields and Grounding:**
 - RS485 cable shield should be joined continuously together and insulated with heat shrink at all devices in the daisy chain that are not a network end point. Do not connect the shields to the device serial port plugs on E2E or

BACnet controllers.

- RS485 cable shield should be securely landed to earth ground at one of the network end points only (preferably at E2E panel if E2E is an endpoint); clip shield wire and insulate on opposite network end point.
- CC200 BACnet MS/TP RS485 port “C” terminal has an internal 100 Ohm connection to RS485 reference ground and the “C” terminal should be connected directly to earth ground/chassis.

7.2. Configuring BACnet Settings on the CC200 Case Display

The network address and device ID makes a board unique from other boards on the network of the same type. This allows the supervisory controller to find it and communicate with it. The Case Controller BACnet settings can be set using the CC200 Case Display.

Identify which CC200 controller will be the router and configure that device according to the instructions in the Router Devices Section. Usually the device that is closest in physical distance from the E2E can be configured as the router in order to keep RS485 cable distance short. However other network cabling factors may dictate that another device is chosen to be the router.

Router Devices

1. Identify the CC200 that will be the MS/TP to IP router. On the router device, the router functionality as well as MS/TP settings must be configured. All other devices will leave router disabled and MS/TP settings are not required.
2. On the router device unlock the display. Push and hold the upper right corner for 5 seconds and the display will beep and **PRG** and **SET** will become visible.





3. With the display unlocked tap and hold **PRG** again for 3 seconds to reach the BAC group for BACnet settings. **BAC** will be displayed.
4. From **BAC**, tap **PRG** again to enter the parameter menu, **ADr** will be displayed. Tap **PRG** to enter edit mode on **ADr**. Swipe up or down on the digits to choose a unique MS/TP MAC for this controller, once selected push and hold **PRG** for 3 seconds to save the edit. Once saved the value will flash, display will beep and return to the **ADr** parameter label.
5. From **ADr** swipe horizontally right to left to reach **baU** for MS/TP baud rate, tap **PRG** to enter edit mode. Swipe up/ down to select the baud rate used for communication with the supervisor controller. Once selected hold **PRG** for 3 seconds to save the value, the value will flash, display will beep and return to the **baU** parameter label.
6. From **baU** horizontal swipe right to left to reach “rid” for rack ID. This sets the refrigeration rack system ID which is used for calculating BACnet device ID. Tap **PRG** to enter edit mode. Swipe up/down to select the rack ID i.e A for rack A, B for rack B. Once selected push and hold **PRG** for 3 seconds to save the edit. Once saved the value will flash, display will beep and return to the rid parameter label.
7. From “rid” horizontal swipe right to left to reach “Lid” for circuit lineup ID. This sets the refrigeration circuit ID which is used for calculating BACnet device ID. Tap **PRG** to enter edit mode. Swipe up/down to select the circuit number. Once selected push and hold **PRG** for 3 seconds to save the edit. Once saved the value will flash, display will beep and return to the Lid parameter label.
8. From Lid horizontal swipe right to left to reach Cid for case id. This sets the case letter ID which is used for calculating BACnet device ID. Tap **PRG** to enter edit mode. Swipe up/ down to select the case letter. Once selected push and hold **PRG** for 3 seconds to save the edit. Once saved the value will flash, display will beep and return to the Cid parameter label.
9. From Cid horizontal swipe right to left to reach CiL for cases in lineup. This sets number of cases in the lineup including this device. For single case systems set = 1, for lineups set the number of cases in the lineup including this device. Tap **PRG** to enter edit mode. Swipe up/down to select the value. Once selected, push and hold **PRG** for 3 seconds to save the edit. Once saved the value will flash, display will beep and return to the CiL parameter label.
10. From CiL horizontal swipe right to reach rtr. This enables/disables the route, tap **PRG** to enter edit mode. Swipe up/down to select yes/no. Select yes only on the CC200 that will be the router. Once selected push and hold **PRG** for 3 seconds to save the edit. Once saved the value will flash, display will beep and return to the rtr parameter label.
11. Lastly, from rtr swipe from right to left to reach **Sav**. Tap **PRG** to enter edit mode. Swipe up/down to select yes/no. Select yes to save and initialize all BACnet changes. Once selected push and hold **PRG** for 3 seconds to save the edit. Once saved the value will flash, display will beep and return to the **Sav**. After **Sav** is set to yes the CC200 will automatically reboot to initialize BACnet settings.

Non-Router Devices

Only the rack id (rid), circuit lineup id (Lid) and case id (Cid) must be set on the non-router devices.

1. With the display unlocked tap and hold **PRG** again for 3 seconds to reach the BAC group for BACnet settings. **BAC** will be displayed.
2. From **BAC**, tap **PRG** again to enter the parameter menu, **ADr** will be displayed. Horizontally swipe from right to left to reach rid.
3. Tap **PRG** to enter edit mode. Swipe up/down to select the rack ID i.e A for rack A, B for rack B. Once selected push and hold **PRG** for 3 seconds to save the edit. Once saved the value

will flash, display will beep and return to the rid parameter label.

4. From rid horizontal swipe right to left to reach Lid for circuit lineup ID. This sets the refrigeration circuit ID which is used for calculating BACnet device ID. Tap **PRG** to enter edit mode. Swipe up/down to select the circuit number. Once selected push and hold **PRG** for 3 seconds to save the edit. Once saved the value will flash, display will beep and return to the Lid parameter label.
5. From Lid horizontal swipe right to left to reach Cid for case id. This sets the case letter ID which is used for calculating BACnet device ID. Tap **PRG** to enter edit mode. Swipe up/ down to select the case letter. Once selected push and hold **PRG** for 3 seconds to save the edit. Once saved the value will flash, display will beep and return to the Cid parameter label.
6. From Cid horizontal swipe right to left to reach CiL for cases in lineup. This sets number of cases in the lineup including this device. For single case systems set = 1, for lineups set the number of cases in the lineup including this device. Tap **PRG** to enter edit mode. Swipe up/down to select the value. Once selected push and hold **PRG** for 3 seconds to save the edit. Once saved the value will flash, display will beep and return to the CiL parameter label.
7. From CiL swipe horizontally right to left to reach “rtr.” Ensure rtr is set to **No** for all non-router devices.
8. Lastly, from rtr swipe from right to left to reach **Sav**. Tap **PRG** to enter edit mode. Swipe up/down to select **Yes** or **No**. Select yes to save and initialize all BACnet changes. Once selected push and hold **PRG** for 3 seconds to save the edit. Once saved the value will flash, display will beep and return to the **Sav**. After **Sav** is set to **Yes**, the CC200 will automatically reboot to initialize BACnet settings.

8. E2 Setup

The Case Controller can communicate with the E2E controller version 4.10F02 or above. Using the Case Controller with E2E offers benefits over using the Case Controller as a standalone device.

- Remotely upgrade firmware of the CC200
- Reporting of Case Controller-related alarms
- The ability to log Case Controller data in an E2E logging group
- The ability to shut down refrigeration in walk in boxes in the event of a refrigerant leak event (available if Emerson leak detection panel is used)
- Remote access to Case Controller status and programming from the E2E front panel
- The ability to remotely access the Case Controllers from UltraSite32, Site Manager, or Connect+

Communication between E2E and the Case Controller takes place over the RS485 BACnet MS/TP network. Follow the instructions in [Section 7, The BACnet Network](#) to connect a Case Controller to the E2E network and comm plug connector. Then follow the instructions in this chapter to set up the Case Controller in the E2E. An E2E has up to three COM ports that can be assigned for BACnet MS/TP communication: COM2, COM4 and COM6 are the available RS485 ports on the E2E power interface board. The Case Controller daisy chain must only be connected to E2E serial port connectors **2a**, **6**, or **4a**.

Connecting a daisy chain of BACnet Case Controllers to the “a” and “b” side of the serial port simultaneously is not supported.

8.1. Set Up Network Ports and BACnet Settings

Before setting up a Case Controller in the E2E, the port that has the BACnet MS/TP cable connected to it must be set up as a BACnet MS/TP port.

1. Log in to the E2E with level 4 access or higher.
2. Press **Alt+M** on the keyboard to access the serial

tab of the general controller info setup screens.

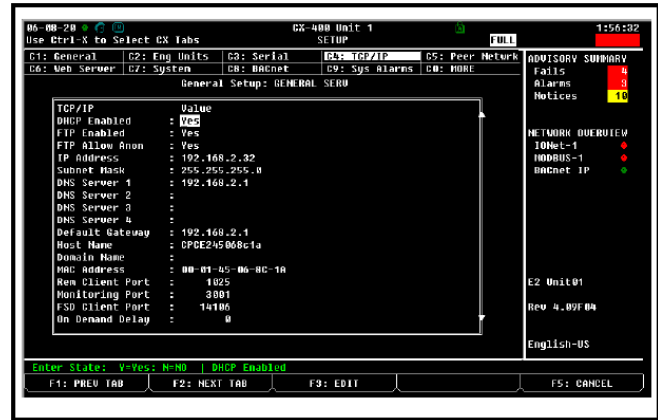
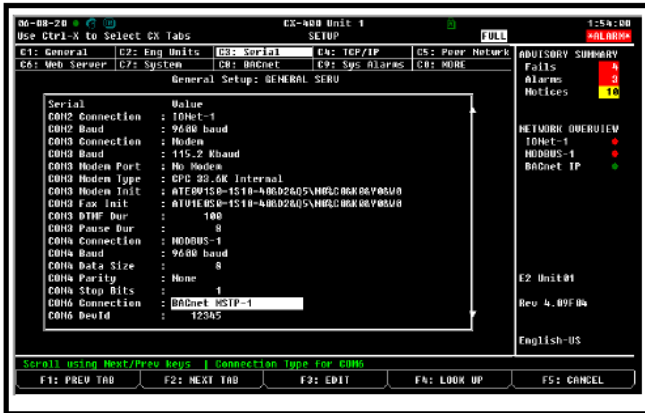

2. Press **Ctrl-8** to reach the **BACnet** tab:

- This screen will have a connection field for all available COM ports on the E2E. Highlight the COM port connection you will be using for BACnet MS/TP and press **F4:LOOK UP** and select **BACnet MS/TP** from the list of network types.

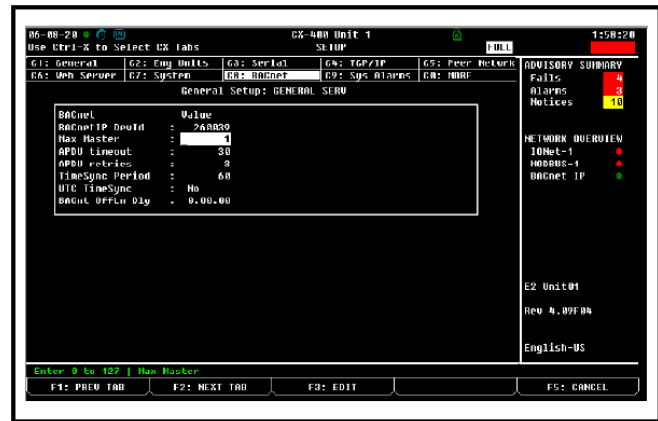

- Three fields will become visible underneath the COM4 Connection that pertain to the way the device communicates:

- COM4 DevId** - This is the E2E BACnet Device ID; set this to a unique number from all other BACnet nodes on the network in the range of **0-4194303**. Usually setting the E2E Device ID the same number as the MSTP MAC is sufficient.
- COM4 MSTP MAC** - This is the E2E BACnet MSTP MAC address; set this to a unique number for E2E in the range of **1-127**. Each BACnet device on the network must have its own unique MSTP MAC in order to communicate.
- COM4 Baud** - Default setting is **9600**; this must be changed to **57600k**. (all devices connected to the same COM port should be set to the same baud rate).

8.2. Configure E2E BACnet Settings

After setting up the BACnet MS/TP port then the BACnet network settings must be configured.

- From the Home screen on E2E press **Alt-T** on the keypad to navigate to this screen:

- Three settings must be configured here:

- Max Master** - The default setting is 127, edit and change the value to be equal to the highest BACnet mac address that E2E will communicate with on any of its three (3) comm ports. A maximum of 32 Case Controllers is allowed per serial port on E2E, setting Max Master to 40 is sufficient to be able to discover all Case Controllers. If there are other BACnet MS/TP devices on the daisy chain besides E2E and Case Controllers, determine the highest MS/TP MAC address of any device connected to any of the E2E comm ports. Set the E2E Max Master equal to the highest MS/TP MAC address determined.
- APDU timeout** - This is the amount of time in seconds between retransmissions of an APDU requiring acknowledgment for which no acknowledgment has been received. Enter a

value of **30** in this field.

- c. **APDU retries** - This is the maximum amount of times that an APDU shall be retransmitted. Enter a value of 3 in this field.

- 4. After timeout, retries, and Max Master have been set, press the button to save and exit.

8.3. Add and Connect Case Controllers

To enable communications between the E2E and the Case Controllers, the devices must be added to E2E and addressed.

1. Log into the E2E with level 4 access or higher.
2. Press & & & to access **Connected I/O Boards and Controllers**.

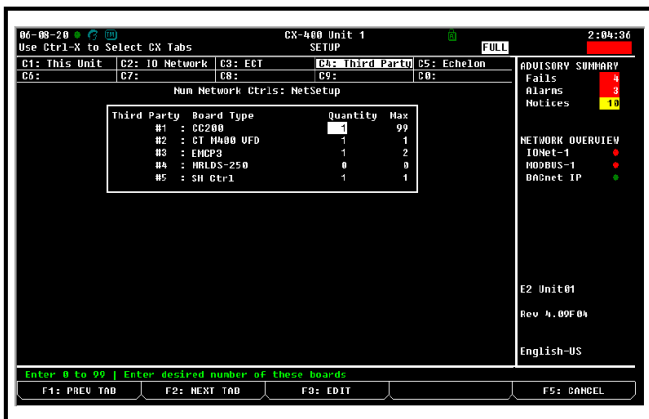

- 3. In the Connected I/O screen under the Third Party tab, enter the number of Case Controller devices in the Quantity field.

- 4. Press the button.
- 5. Press the button to return to the home screen.
- 6. Press **Alt + N** on the keyboard to access the Network Summary screen.
- 7. The number of Case Controller units added in Step 3 should now be visible in the Network Summary screen.

8.4. Commissioning the Device in E2E

- 1. From the network summary screen highlight the first device and press to commission the device.

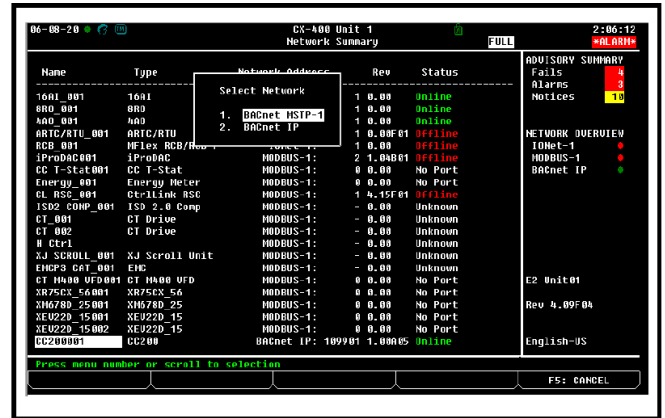

- 2. Select the BACnet MS/TP network, the E2E will then scan for available devices:

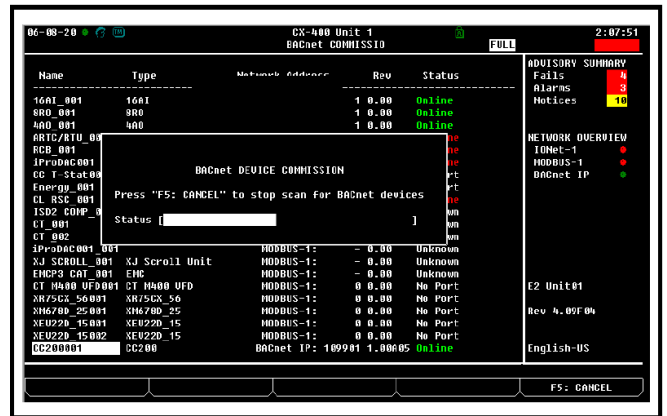

- 3. The E2E will display a list of the devices discovered during the scan:

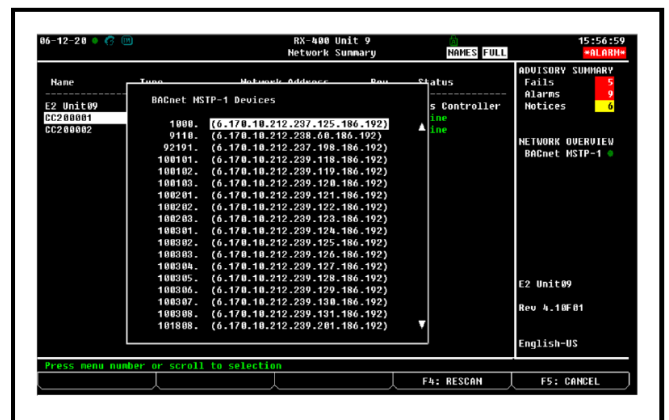

- The number in parenthesis is the BACnet MAC address and the six-digit number adjacent to it is the BACnet Device ID. Select the device you want to commission and press  on the E2E keypad.

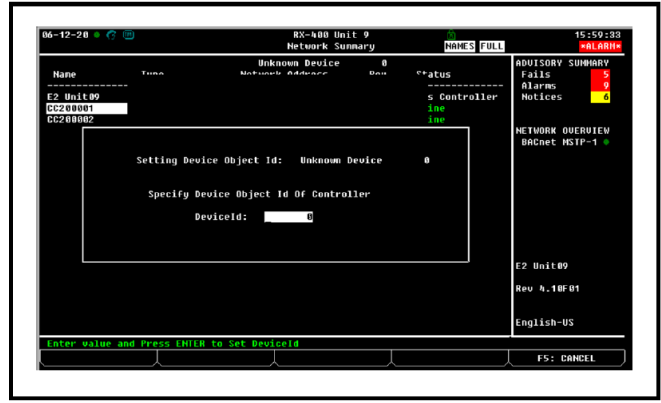

- Then press the  button to save and exit back to the Network Summary screen:

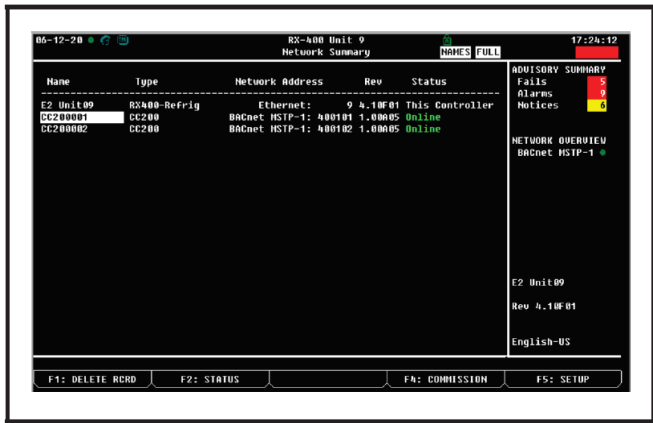

- Press  again on E2E keypad and then E2E will display **BACnet Device ID is set**.

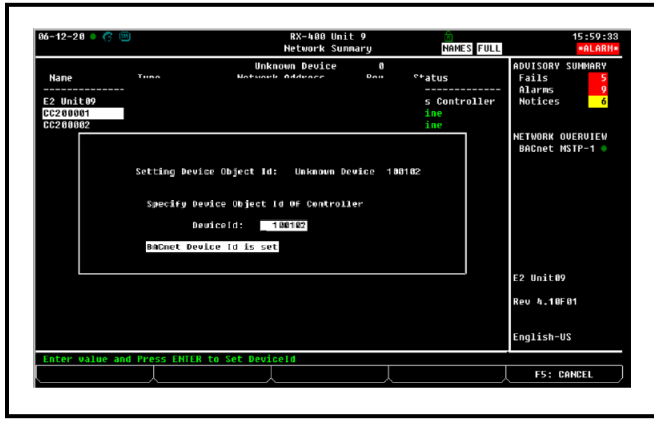

9. Cold Chain Connect™ Mobile Application

Cold Chain Connect is a mobile application for connecting to the Emerson CC200 refrigerated case controller. This section is a guide for using the Cold Chain Connect App to set parameters, graph inputs and outputs, set service overrides, and view alarms. Cold Chain Connect provides a window into CC200 operation and diagnostics directly at the location of the refrigerated fixture or walk-in box.

1. Download the Cold Chain Connect Application

- a. Visit the App store and download the Cold Chain Connect App from the Apple Store at Apple: <https://www.apple.com/ios/app-store> or scan the QR code:



2. Register the App

- a. Select **New User? Register**.
- b. Fill out all the required fields and press **Register**.
- c. You will receive an email once your account has been activated.

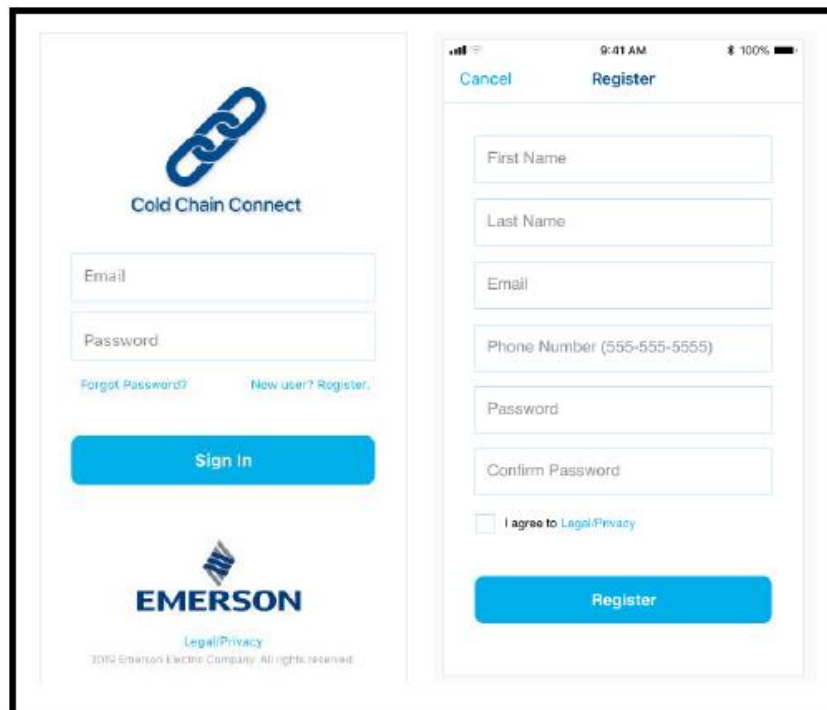

3. How to Activate Bluetooth® on the CC200 Case Display

- a. **Step 1 - Unlock Screen:** Press and hold for three seconds on the top RIGHT corner of the screen. Once the Display is unlocked, **SET** will be visible in the bottom left corner and **PRG** will be visible in the top right corner:

Note: After 5 minutes with no touch activity, the Display keyboard locks automatically.

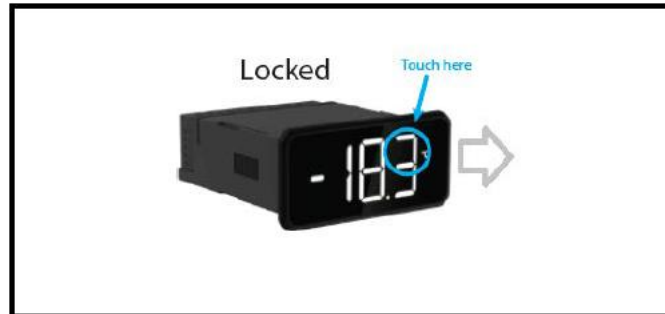

- b. **Step 2 - Virtual Keyboard:** Swipe LEFT or RIGHT to navigate to the virtual keyboard:



- c. **Step 3 - Turn ON Bluetooth:** From the virtual keyboard, press and hold the Bluetooth icon on the top RIGHT corner for three seconds.
- d. Once Bluetooth is activated, a small Bluetooth status icon in the lower right corner of the Display will begin to blink slowly, indicating the CC200 is ready for connection. The Bluetooth status icon turns solid when Cold Chain Connect is actively connected.

Note that After 10 minutes with no connection from Cold Chain Connect, Bluetooth on the CC200 switches off automatically.



4. Connecting to a Case

- Once the CC200 Bluetooth is ON and the Bluetooth icon is blinking slowly, the CC200 is ready to connect to the Cold Chain Connect App.
- Turn Bluetooth ON the mobile device or tablet. Open Cold Chain Connect and sign in. After signing in, Cold Chain Connect will scan for nearby CC200 controllers and available controllers will be displayed as shown in the screen below.
- Tap the name of the CC200 you wish to connect to:

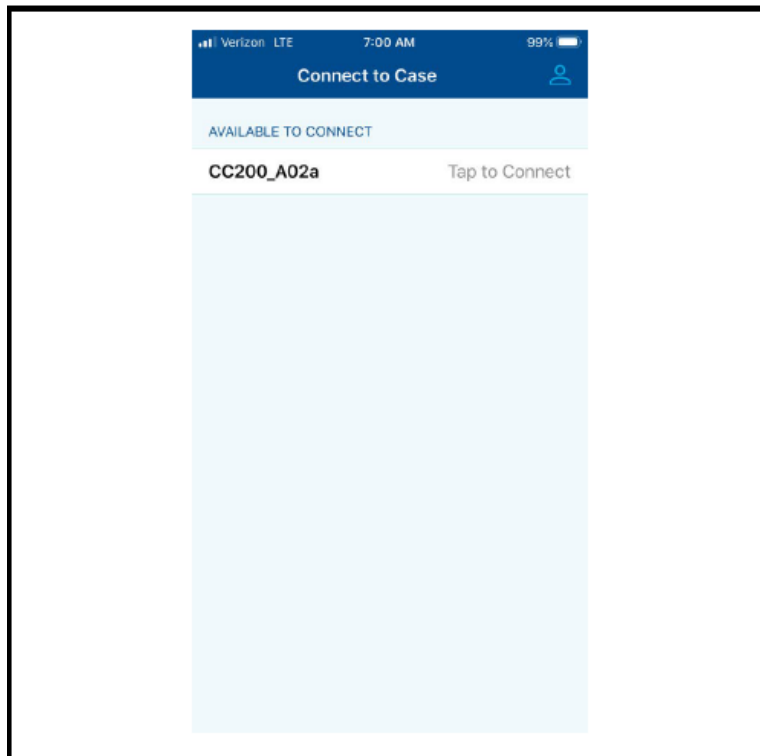

5. Information on the Case Tab

Once a connection with a CC200 has been established, the Case tab will appear with CC200 status information and available service commands.

- Case temps
- Case Superheat
- Status of the relay outputs
- Overrides
- Pressures
- Alarms

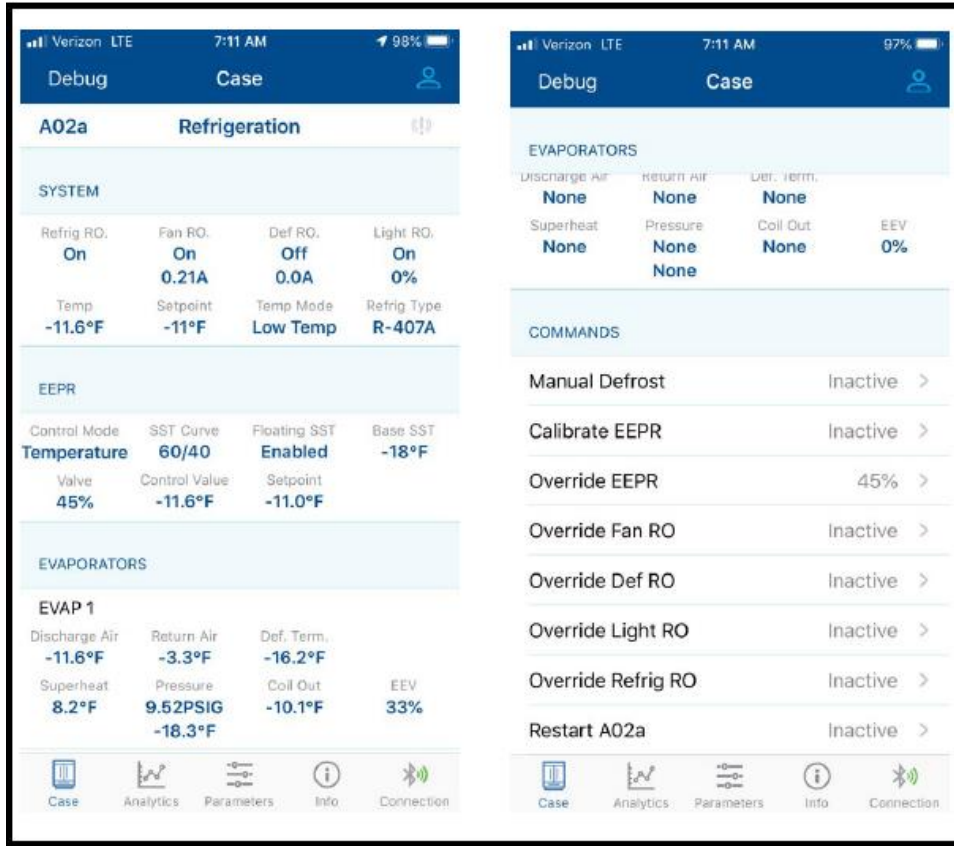

6. How to Set Parameters

- a. Select the **Parameters**  tab at the bottom of the application.
- b. On the Parameters screen a list of parameter groups is shown.
- c. Touch the first group name to enter the group and begin the configuration process.
 - Each group will have a list of parameters and a description. The current value of the parameter is shown in blue to the right of the name.
- d. Touch the first parameter in the group to bring up the edit control.
 - Enter the desired value and press **Done**. The new edit will be shown above the original value of the parameter.
- e. Edit all the desired parameters within the group.
 - Press **Save** in the top right corner of the Group screen.

*Note: Pressing **Back** discards any edits selected for that group and they will not be saved to the CC200.*

- f. Repeat the procedure for all the groups.

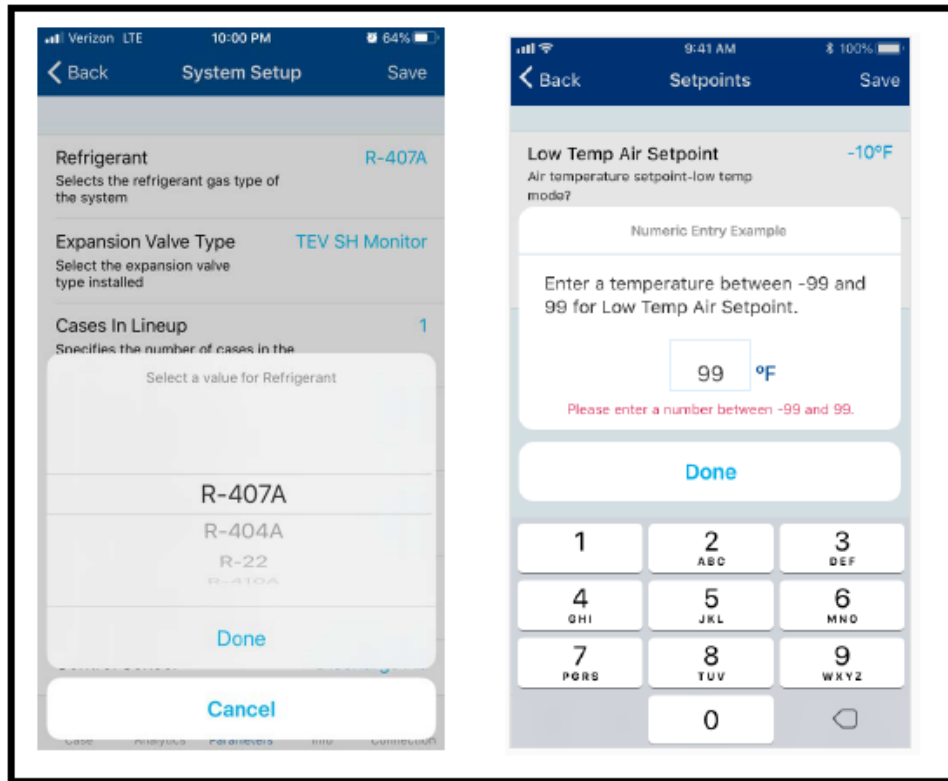

7. Manual Defrost

- a. From the dashboard, scroll down to **COMMANDS**.
- b. Select **Manual Defrost**.
- c. A pop-up will appear with two options:
 - Manual Defrost
 - This option puts the CC200 into a defrost cycle immediately. The CC200 will terminate the defrost according to the programmed defrost parameters as if it were a normally scheduled defrost cycle.
 - Emergency Defrost
 - This option puts the CC200 into a defrost cycle immediately; however, the CC200 will run the defrost cycle for the maximum period of time programmed in the defrost parameter group.
- d. To cancel the Manual Defrost or Emergency Defrost:
 - Select Manual Defrost again and now, a pop-up to End Manual Defrost will appear. Select **End Manual Defrost** and the defrost is now cleared.

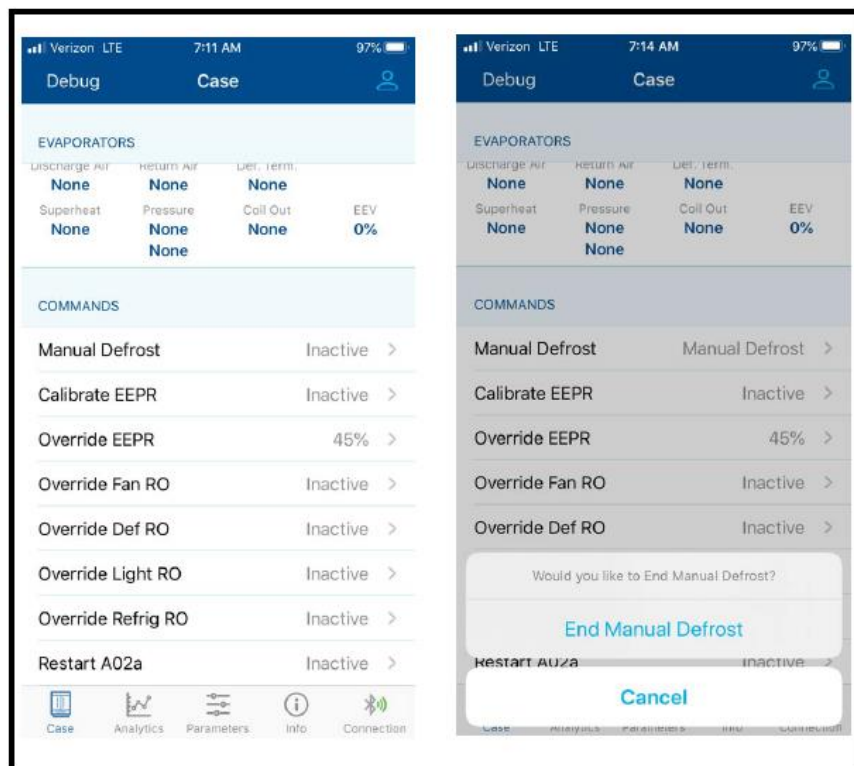
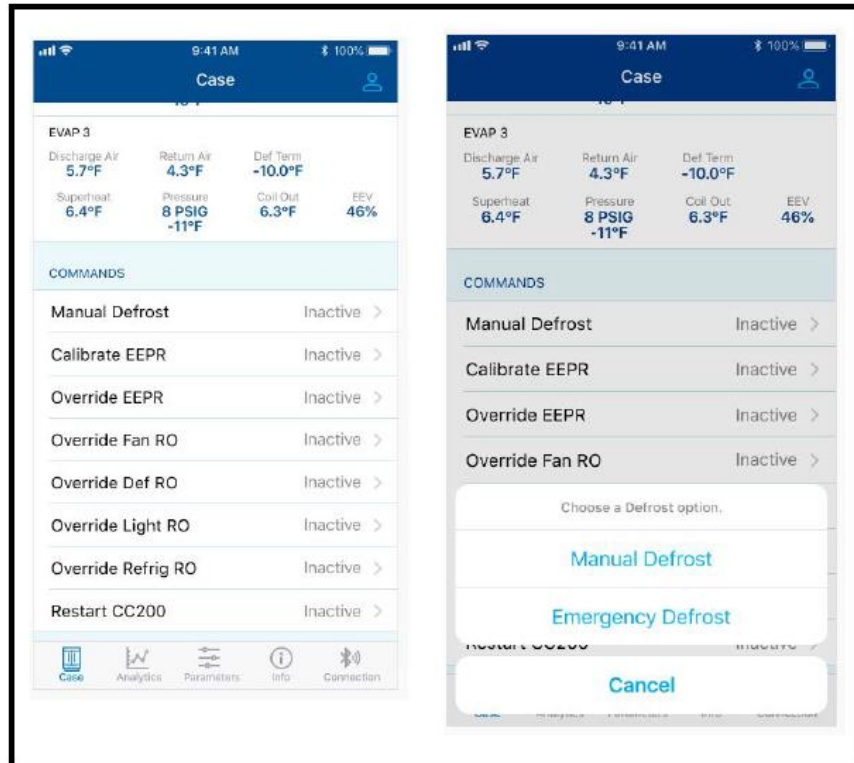

8. Calibrate Valve

- a. From the dashboard, scroll down to **COMMANDS**.
- b. Select **Calibrate EEPR**.
- c. The valve will start calibrating.

Note: The calibration cannot be stopped once it has started.

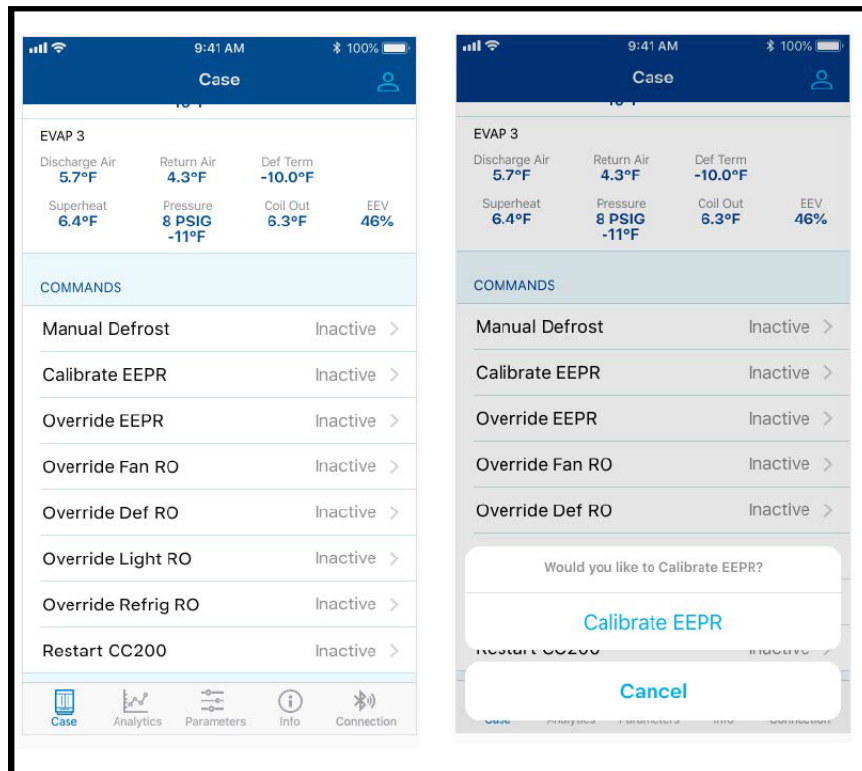

9. Overrides

- a. From the dashboard, scroll down to **COMMANDS**.
 - You will see a list of overrides that can be manually configured.
 - All overrides are timed and with a maximum time of 10 minutes.
- b. Select the desired override to enter on the Override screen.
- c. In the Override screen, toggle the switch and two new fields will become visible.
- d. Select the override value and length of time. A maximum time duration of 10 minutes is allowed for all overrides.
- e. Once a value and length of time have been chosen, press **Save** to set the override. The override can be changed at any time by re-entering the screen, choosing a different value, and pressing **Save**.
- f. Active overrides will be highlighted blue in the dashboard for easy identification.

- g. To cancel an active override, tap the override from the main case tab. Turn off the green toggle switch and press **Save**.

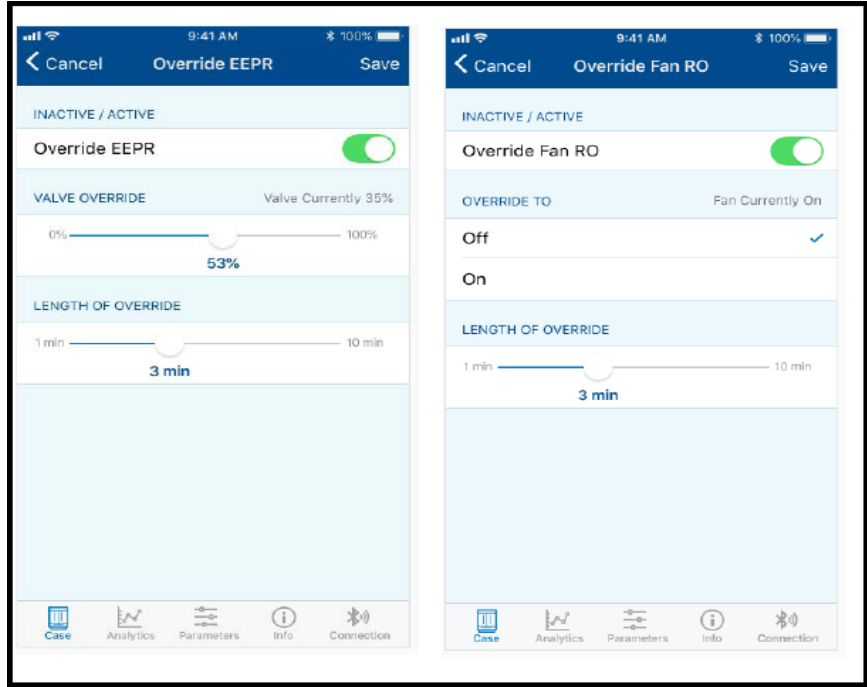



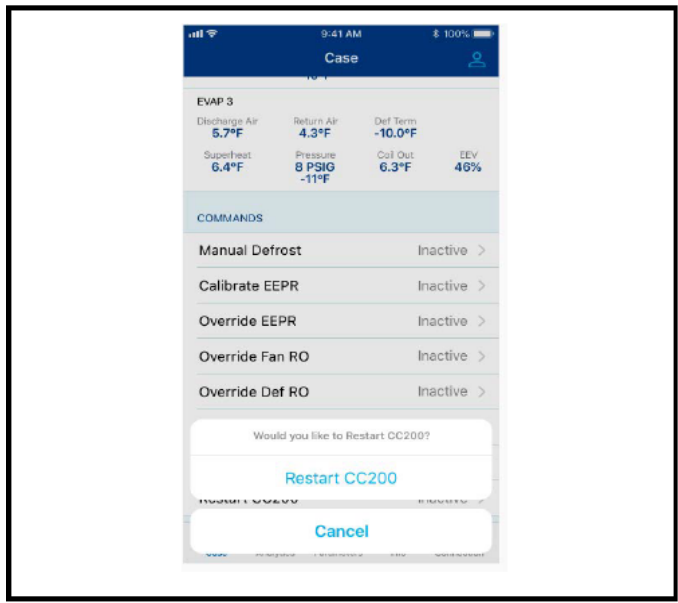

10. Restart the CC200

For convenience and service there is a command to reboot the CC200. To reboot the CC200, select the **Restart CC200** command from the list. A pop-up will be shown to confirm the action. The CC200 controller will perform a soft reboot and status information will be temporarily unavailable in the Cold Chain Connect dashboard.



11. Real-Time Graphs

- a. Select the **Analytics**  tab at the bottom of the application.
- b. Select **Filter**  at the top of the application.
 - Select the desired values to graph from the list of available CC200 data points and press **Apply**. Cold Chain Connect will begin building the graph.
 - A maximum of two analog data types and two ON/OFF data types can be graphed simultaneously. Tap the graph line anywhere to see a plot marker of the value at that point in time.
- c. Select  and you will be able to select three options:
 - 5minutes
 - 10 minutes
 - 15 minutes
- d. Select **Share**  at the top of the application.
 - You will be prompted to share the graph.

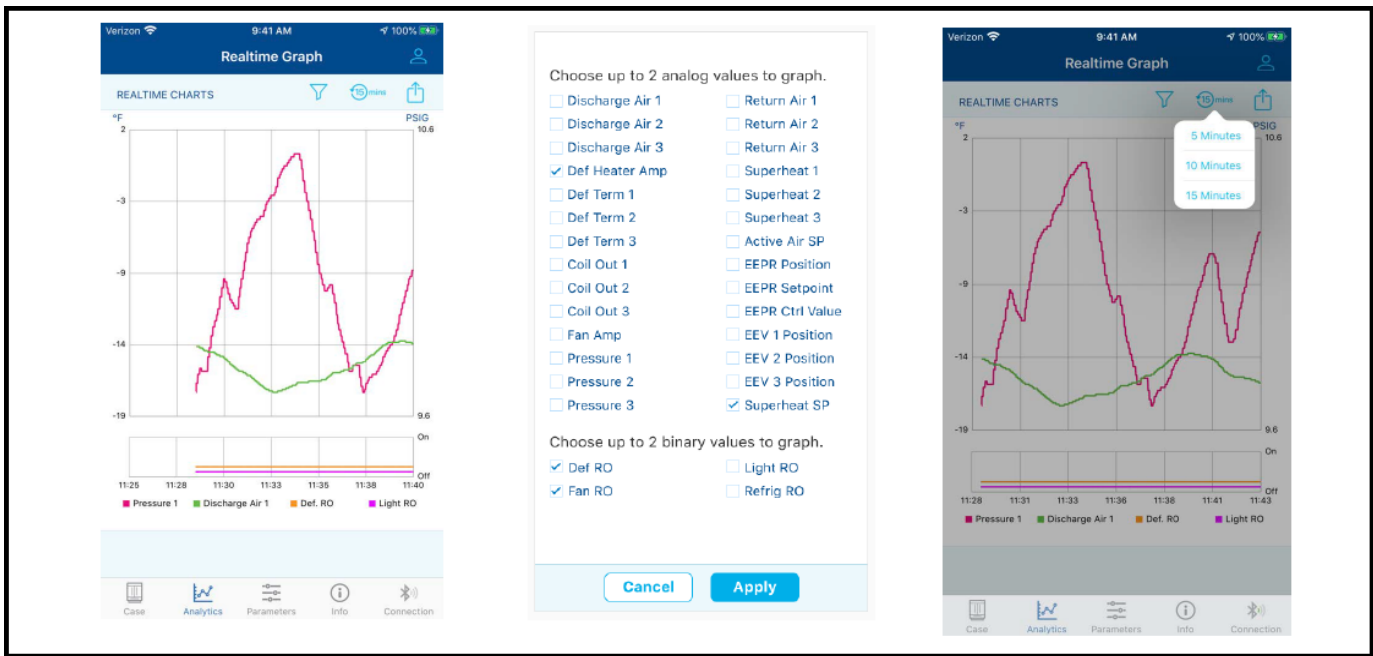

12. Viewing Alarms

Active CC200 alarms can be viewed in the case tab by tapping the alarm icon in the upper right corner of the case screen. When one or more alarm conditions are active the alarm icon will be red, if there are no active alarms the icon will be gray and the count will be zero.

An alarm icon will appear next to any piece of data in the Case tab that has an active alarm. Tap the icon next to the data point to see the description.

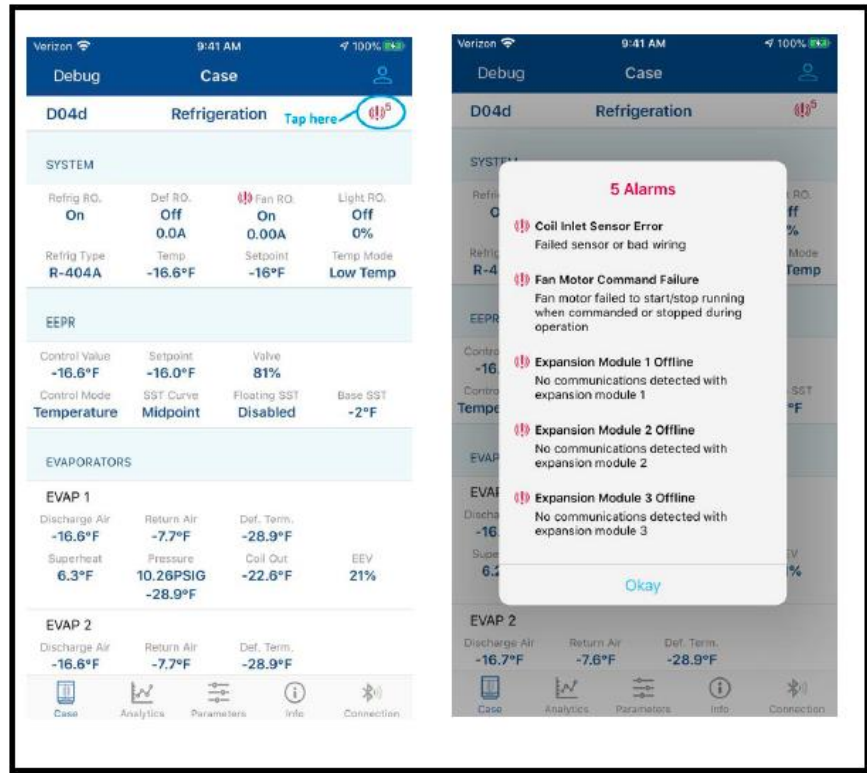

13. Info

Select Info  at the bottom of the application and you will see the Store info, CC200 version, and the Cold Chain Connect version:

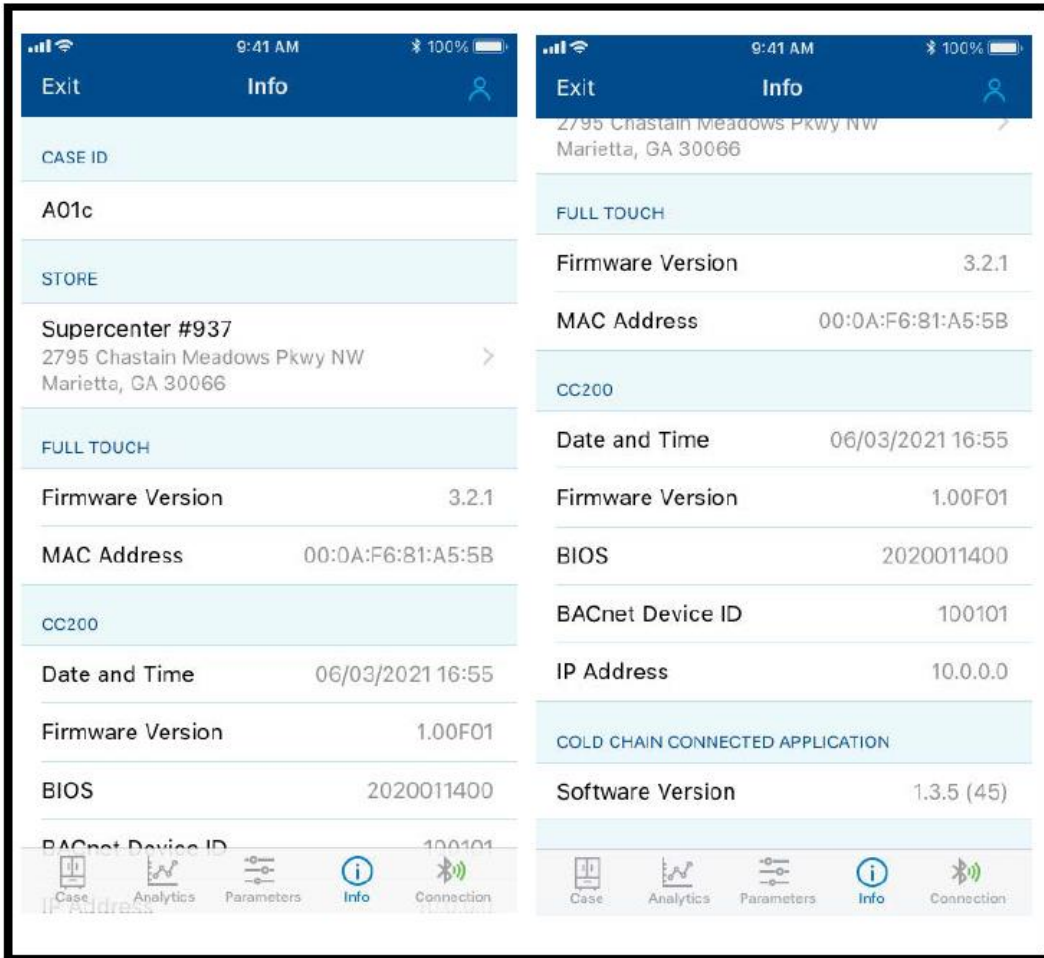

14. Disconnect from the Case

- a. Select Connection  at the bottom of the application.
 - You will see a pop-up asking you to Disconnect.
 - Select **Yes, Disconnect** and you will be disconnected from the case:

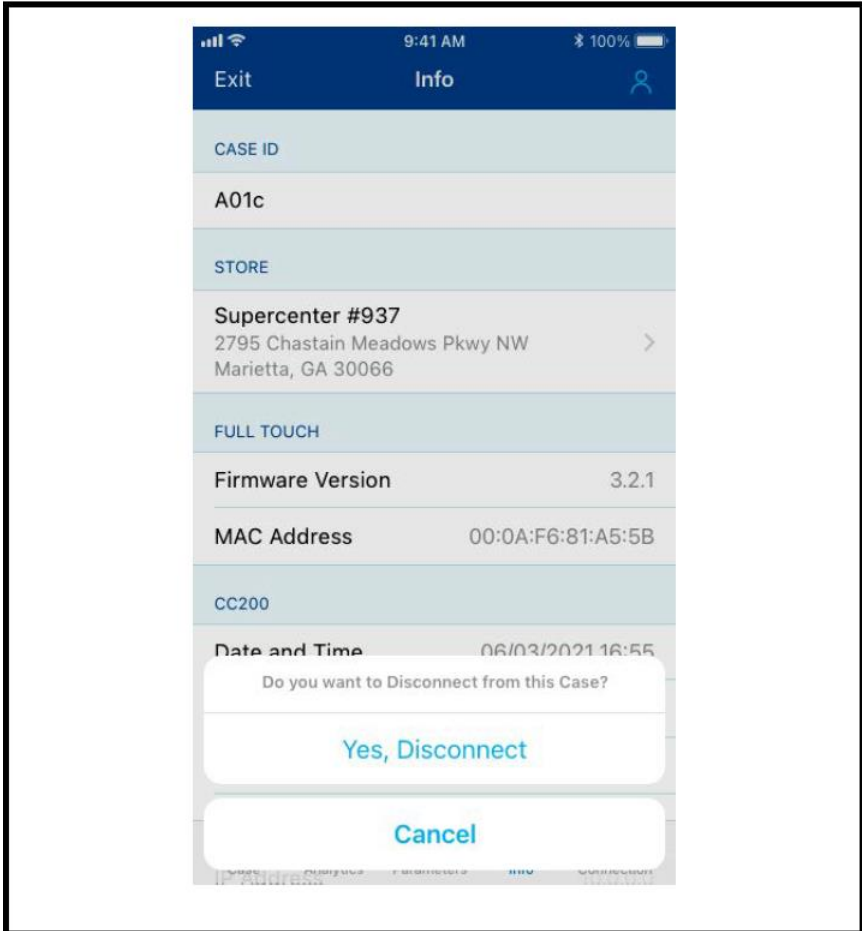

10. Configuring CC200 Parameters

The Cold Chain Connect mobile application provides the ability to quickly configure all CC200 parameters from your mobile device or tablet. In most installations the CC200 will arrive from the OEM factory already configured for the walk-in or case it will be controlling. If on-site configuration is required, the table and figure below will explain the configuration process. Access and navigation of the Cold Chain Connect application is covered in **Section 9, Cold Chain Connect™ Mobile Application**.

1. Connect to the CC200 to be configured and navigate the parameters tab .
2. The list of parameter groups is shown:

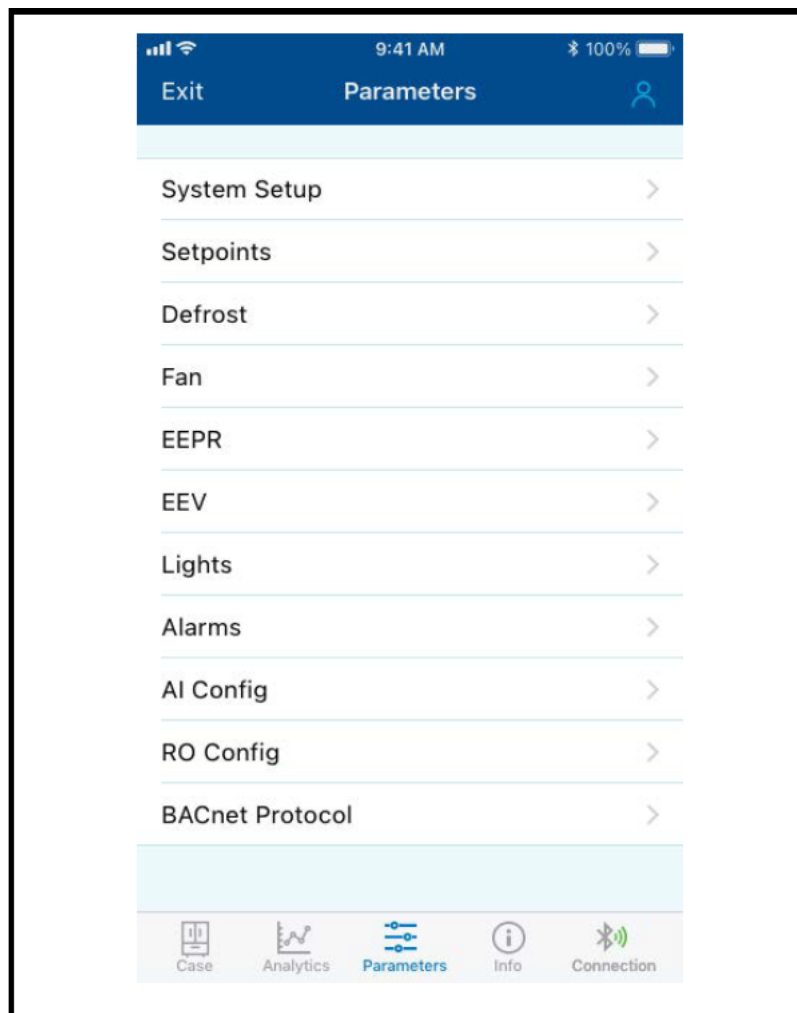

3. Tap on system setup to begin configuration, set the value of each parameter according to the system requirements and recommended action shown below. Push save at the top of each group once edits have been made.



System Setup	
Parameter	Recommended Action
Refrigerant	Select the refrigerant type for the system installation.
Expansion valve Type	Select the type of expansion valve that is installed in the system. TEV = Thermostatic Expansion Valve TEV SH Monitor = TEV with superheat monitoring. CC200 will expect pressure sensors and coil outlet sensors to monitor each coil's superheat. Stepper EEV = Stepper motor electric expansion valve. CC200 will control superheat by positioning the stepper valve EEV. PWM = Pulse width modulated expansion valve, CC200 will control superheat by controlling a PWM expansion valve.
Cases in Lineup	Specifies the number of cases in the refrigeration lineup. For cases connected in a lineup, enter the number of cases in the lineup. Enter 0 for cases that are stand alone and not part of a lineup. Enter 0 for walk in boxes.
Case Temp Mode	Select the type of temperature application for the case or walk in box. Dual temperature cases should select Dual, CC200 will shift between low and medium setpoints for dual temperature cases.
Number of Coils	Select the number of evaporator coils installed in the system.
Continuous Refrigeration	No = REFRIG RO on the controller relay outputs will cycle on/off with air temperature setpoint and dead band. Yes = REFRIG RO stays on constantly during refrigeration except for during defrost and service or leak shutdowns. <i>Note: A value of Yes should be selected for systems using EEPR. A value of yes should be selected for systems using PWM or Stepper EEV control.</i>
LLSV Present	Select if a liquid line solenoid is wired to REFRIG relay output.
Control Sensor	Select the type of air sensor used to control air temperature in the case or walk in. Typically discharge air is selected for cases and return air is selected for walk in boxes.
Case Temp. Combination	For multi coil cases or walk in boxes with more than one air sensor installed a combination method is applied to the value of all the sensors. The combined value is then passed to control logic for controlling the air temperature. Typically, average is selected.
PWM Valve Period	Enter the period for the PWM valve. Enter the value from the PWM EEV OEM data sheet.



PWM Short Cycle	This is the PWM Valve minimum control % and prevents short cycle of valve by limiting the minimum ON time of Valve during the Pulse Period. The upper control percent is 100%. The control value will be linear from PWM Short Cycle to (100% - PWM Short Cycle). To obtain maximum capacity, the PWM valve percentage will step from (100% - PWM Short Cycle) to 100% to prevent short cycle of valve at top end of control range (limits minimum OFF time of Valve during the Pulse Period).
-----------------	--

4. Once System Setup parameters are set and saved, tap on the Setpoints group. Set the value of each parameter according to the system requirements and recommended action shown below:

Setpoints	
Parameter	Recommended Action
Low Temp Air Setpoint	Enter the low temperature air setpoint that the case or walk in box temperature should be regulated to. The case will operate on this setpoint when Case Temp Mode is set to low or when set to dual and the dual temperature input is in low temp mode.
Medium Temp. Air Setpoint	Enter the medium temperature air setpoint that the case or walk in box temperature should be regulated to. The case will operate on this setpoint when Case Temp Mode is set to medium or when set to Dual and the dual temperature input is in medium temp mode.
Air Setpoint Deadband	This is the dead band for air temperature regulation and is split half above and half below the active air setpoint. When Continuous Refrigeration is set to No, the REFRIG RO on the controller will cycle on/off based on this deadband and the air temperature setpoint.
Superheat Setpoint	Superheat control setpoint that all evaporators will be controlled to. Enter the superheat setpoint from the case/walk in OEM data sheet
Superheat Deadband	Deadband around sh setpoint (+/- half) The Emerson default value is sufficient unless adjustments to evaporator performance are required.
Max Pulldown Time	This duration specifies the maximum amount of time the case can remain in a post defrost pulldown.
Door Disables Refrig.	When a door switch digital input is configured this parameter will determine if CC200 shuts off refrigeration for each door opening. No = Refrigeration will remain on during door openings. Yes = Refrigeration will shut off during door openings and turn back on when door closes.



Door Failsafe Timeout	If Door Disables Refrig. is set to Yes then this parameter defines the maximum amount of time refrigeration can remain off before automatically resuming operation again.
-----------------------	---

5. Once Setpoints parameters are set and saved, tap on the Defrost group. Set the value of each parameter according to the system requirements and recommended action shown below:

Defrost	
Parameter	Recommended Action
Heat Type	Select the type of defrost heat for the case or walk in. Off Cycle = Refrigeration is turned off, warm air in the case defrosts the evaporator coil. Electric = Refrigeration is turned off, DEFROST RO on the controller is energized to turn on an electric heater.
Defrost Start Time	Enter the start time for the first defrost cycle. Defrost cycles will be spaced evenly through 24 hours based on start time and Cycles Per Day .
Cycles Per Day	Enter the number of defrost cycles in 24 hours.
Termination Type	Select the termination strategy for the case or walk in box. Maximum Time is respected for all termination types. Time = The defrost cycle will run for the Minimum Time and terminate after the Maximum Time is reached. Temp = The defrost cycle will run for the Minimum Time and terminate once the Termination Sensor reaches the Term. Temp. Setpoint DI = The defrost cycle will run for the Minimum Time and terminate once the defrost termination digital input is On.
Termination Sensor	Select the termination sensor that is installed in the case or walk in box.
Term. Combination	For multi coil cases or walk in boxes there can be one termination sensor per evaporator coil. A combination method is applied to the sensor values to determine the final termination value.
Term. Temp. Setpoint	Enter the manufacturers recommended setting. When Termination Type is set to temperature the CC200 will terminate defrost once the termination temperature reaches this setpoint.
Minimum Time	Enter the manufacturers recommended setting for defrost minimum time. This is the minimum duration the defrost cycle must run before termination is allowed.
Maximum Time	Enter the manufacturers recommended setting for defrost maximum time. This is the maximum duration the defrost cycle can run.



Drip Time	Enter the manufacturers recommended setting for defrost drip time. This is the duration after defrost and before refrigeration or fan resumes to allow moisture to fall into the drain pan.
Pump Down Time	Enter the desired pump down delay time here, if set to 0 then no pump down procedure will occur.

6. Once Defrost parameters are set and saved, tap on the Fan group. Set the value of each parameter according to the system requirements and recommended action shown below:

Fan	
Parameter	Recommended Action
Fan In Refrig.	Select if the fan should be continuously on during refrigeration or cut in/cut out. Continuous On =Fan never cycles off during refrigeration. Cut In/Cut Out =Fan cycles off with REFRIG RO when air temperature is satisfied.
Fan In Defrost	Select if the fan should be on or off during defrost.
Delay Method	Select if the fan delay method once refrigeration resumes after defrost. For no fan delay select, Time and enter 0 in Delay Time. Time Delay =Fan will be delayed for duration of Delay Time parameter. Coil Temp =Fan will be delayed until the coil outlet sensor drops below the temperature defined in Delay Temp. parameter.
Delay Time	If Delay Method is set to time delay then fan will be delayed for the duration defined here.
Delay Temp.	If Delay Method is set to coil temp then fan will be delayed until the coil outlet sensor reaches the temperature defined here.
ECM Present	Determines if an Electronically Commutated Motor type is used for evaporator fan. No = No ECM type used for evaporator fans. Yes =ECM type motors in use for evaporator fans.

7. Once Fan parameters are set and saved, tap on the EEPR group. Set the value of each parameter according to the system requirements and recommended action shown below:

EEPR	
Parameter	Recommended Action
Enable EEPR	Set to Yes if there is an EEPR installed in the case or walk in box.
EEPR Motor Type	Select the EEPR valve motor type for the valve installed.



Control Mode	Select the type of control desired for EEPR logic. SST/Pressure =EEPR will regulate the saturated suction temperature to the currently active SST setpoint. Discharge Air =EEPR will regulate air temperature inputs to the air temperature setpoint.
EEPR Cal. Method	Select the calibration method for the EEPR stepper valve according the valve manufacturer recommendation. Every Defrost =The valve calibration will be performed during each defrost cycle. First Defrost Only =The valve calibration will only be performed during the first scheduled defrost of the day.
Refrigerant Curve	Select the PT conversion method for the EEPR control when Control Mode is SST/Pressure. The options are dew, 60/ 40 Avg, Mid and bubble point. Midpoint or 60/40 Avg is recommended for EEPR control of SST. 60/40 Avg. is a weighted average of 60% dew point and 40% bubble point.
Low Temp. SST Setpoint	Enter the case or walk in low temperature saturated suction temperature setpoint from the manufacturer recommendation. The low temp setpoint will be used when Case Temp Mode is Low or when dual temperature is in low temp mode.
Med Temp. SST Setpoint	Enter the case or walk in medium temperature saturated suction temperature setpoint from the manufacturer recommendation. The medium temp setpoint will be used when Case Temp Mode is medium or when dual temperature is in medium temp mode.
Float Band	When Control Mode is SST/Pressure the floating SST algorithm can be enabled. A value of 0 disables floating SST, a value of 4-6 is suggested for floating SST. See Section 5.7.2 of this manual for an overview of the floating SST algorithm.
Max Steps	Enter the maximum steps for the EEPR valve from the valve OEM recommendation.
Step Rate	Enter the step rate for the EEPR valve from the valve OEM recommendation.
Over Close	Enter the overclose % that the valve should be over driven during calibration.
Relax Steps	The amount of steps to open the valve after calibration. Generally, 4 steps or more are needed to "relax" valve seat tension. Entering a number of steps too large could result in refrigerant flow with valve at 0%.
Minimum Opening	The minimum amount of opening for the EEPR valve during refrigeration.
Proportional	The proportional band for EEPR PID regulation. The proportional band is applied above the setpoint, P output will be 100% at the top of setpoint plus P band. A starting value of 25 for EEPR regulation is recommended.
P Band Offset	Enter the proportional band offset. For most applications this parameter can remain 0.



Integral	The Integral term for EEPR PID regulation. A large I value means less output from the I term, a smaller I value means more output from the I term. A starting value of 180 for EEPR regulation is recommended.
Derivative	The derivative term for EEPR PID regulation. For most applications the D can remain 0.
Derivative Time	The derivative time value for EEPR PID regulation. For most applications the derivative time can remain 0.

EEV	
Parameter	Recommended Action
EEV Cal Method	Select the calibration method for the EEV stepper valves according the valve manufacturer recommendation. Every Defrost =The valve calibration will be performed during each defrost cycle. First Defrost Only =The valve calibration will only be performed during the first scheduled defrost of the day. The factory default of First Defrost Only can be left when Sporlan SER EEV's are used.
EEV 1 Motor Type	Select valve motor type for the valve installed Unipolar Bipolar
EEV 2 Motor Type	Select valve motor type for the valve installed Unipolar Bipolar
EEV 3 Motor Type	Select valve motor type for the valve installed Unipolar Bipolar
Start Position	The percentage position of the valve at each regulation cycle start (post defrost and on initial controller power up). The valve will be at this position for the time defined in <i>Start Hold Time</i> .
Start Hold Time	The amount of time the valve will remain at the Start Position. Once the time expires the valve will return to normal regulation control.
Max Steps	Maximum steps for the stroke of the valve. Enter the maximum steps from the valve OEM data sheet.
Step Rate	Step rate (steps/second) to move the valve. Enter the step rate from the valve OEM data sheet.



Overclose	The percentage of the max steps to over close the valve during calibration. The default value of 10% is sufficient.
Relax Steps	Steps to open the valve immediately after calibration to release torque on the valve needle. Generally, 4 steps or more are needed to “relax” valve seat tension. Entering a number of steps too large could result in refrigerant flow with valve at 0%.
Min Opening	Minimum allowed opening percentage during superheat regulation. A value of 0 is recommended for properly sized valves.

8. Once EEPR parameters are set and saved, tap on the Lights group. Set the value of each parameter according to the system requirements and recommended action shown below:

Lights	
Parameter	Recommended Action
Control Mode	<p>Select the lighting control mode:</p> <p>DI Triggers: The lights turn on when the motion input is true or the door input is true. The lights remain on for the duration defined by ON DURATION.</p> <p>Schedule w/Dimming: The lights will turn on/off during the local schedule times. When the lights are scheduled on, light dimming will be applied when motion is detected by the motion input.</p> <p>Supervisor w/Dimming: The lights will turn on/off according to the supervisor controller command. When the lights are scheduled on, light dimming will be applied when motion is detected by the motion input.</p> <p>Local Schedule Only: The lights will turn on/off based on the local schedule time only. No dimming.</p> <p>Supervisor Control: The lights will turn on/off based on the supervisor command only.</p>
Door Lights On	When a door switch digital input is configured door opening can cause lights to turn on. Set DOOR LIGHTS ON to ON for door openings to cause lights to turn on.
Motion Lights On	When a motion switch digital input is configured and the lights control mode is set to DI TRIGGERS or a dimming mode the motion switch can cause lights to turn on. Set MOTION LIGHTS ON to ON for door openings to cause lights to turn on.
On Duration	If lights turn on due to door switch or motion switch they will remain on for this duration after a rising edge of the switch.
Maximum Dim	When the Motion input changes to an active state, the Dimming output will change from its minimum value to the maximum value proportionally over a three second period. If the Motion input is inactive for five minutes, the Dimming output will change from its maximum value to the minimum value proportionally over a five second period.



Minimum Dim	When the Motion input changes to an active state, the Dimming output will change from its minimum value to the maximum value proportionally over a three second period. If the Motion input is inactive for five minutes, the Dimming output will change from its maximum value to the minimum value proportionally over a five second period.
Lights On Time	Enter the on time HH:MM for the lights to turn on. The off time can also be set before the on time if the schedule needs to continue into the following day or an off schedule is preferred.
Lights Off Time	Enter the off time HH:MM for the lights to turn off. The off time can also be set before the on time if the schedule needs to continue into the following day or an off schedule is preferred.

9. Once Lights parameters are set and saved, tap on the Alarms group. Set the value of each parameter according to the system requirements and recommended action shown below:

Alarms	
Parameter	Recommended Action
Temp. Alarm Hi	This is the high temperature alarm setpoint for the case. If the air temperature rises above this setpoint for longer than the delay an alarm is generated.
Temp. Alarm Low	This is the low temperature alarm setpoint for the case. If the air temperature falls below this setpoint for longer than the delay an alarm is generated.
Temp. Alarm Delay	The delay before generating a case air temperature alarm.
Temp. Delay After Def.	The case temperature alarming is delayed after defrost for the duration entered here
Low SH. Alarm	The alarm setpoint for a low superheat condition. When superheat drops below Low SH Alarm for the Low SH Alarm Delay, a low superheat alarm will result.
Low Sh. Alarm Delay	Enter the duration for the low superheat alarm delay
Fan Proof On	The amperage level required to consider the fan motor running.
Fan Proof Off	The amperage level required to consider the fan motor off.
Fan Proof Delay	When the fan feedback status does not match the fan command value for FAN PROOF DELAY, a command failure alarm will result.
Defr Proof On	When defrost heater amperage rises above the DEFR PROOF ON level the defrost heater shall be considered ON.
Defr Proof Off	When defrost heater amperage falls below the DEFR PROOF OFF level the defrost heater shall be considered OFF.
Defr Proof Delay	Delay time before defrost heater command failure alarm. If the defrost proof status and the commanded value for the defrost heater do not match then a defrost command failure alarm will result.



Door Alarm Delay	When a door switch digital input is configured, a door alarm will occur when the door is left open for the duration specified here.
------------------	---

10. Once Lights Alarms are set and saved, tap on the AI Config group. Set the value of each parameter according to the system requirements and recommended action shown below:

AI Config	
Parameters	Recommended Action
DAT Config	<p>Select the discharge air configuration. For walk in boxes, set the value to Not Used and use RAT Config to configure the air sensor.</p> <p>Not Used = No discharge air sensors are used for control</p> <p>1 Per Coil = Discharge air sensors are installed on each evaporator coil</p>
RAT Config	<p>Select the return air configuration. For walk in boxes, set the value to 1 Per Coil and set DAT Config to Not Used. If return air sensors are installed in cases, set the value to 1 Per Coil here.</p> <p>Not Used = No return air sensors are used for control</p> <p>1 Per Coil = return air sensors are installed on each evaporator coil</p>
Pressure Config	<p>Select the pressure transducer configuration to match the installation of the case or walk in box.</p> <p>1 Per Coil = There is one pressure transducer installed for each evaporator coil</p> <p>1 Per Case = There is one pressure transducer installed for the entire case.</p> <p>For 1 Per Case configurations with multiple coils, CC200 will use the single transducer value to calculate superheat for all coils.</p>
Pressure 1 Scale	Select the high end engineering unit scale for pressure transducer 1 that matches the transducer specification. Options of 100, 150, 200 and 300 PSI are available. Only 5VDC .5-4.5 VDC signal transducers can be used.
Pressure 2 Scale	Select the high end engineering unit scale for pressure transducer 2 that matches the transducer specification. Options of 100, 150, 200 and 300 PSI are available. Only 5VDC .5-4.5 VDC signal transducers can be used.
Pressure 3 Scale	Select the high end engineering unit scale for pressure transducer 3 that matches the transducer specification. Options of 100, 150, 200 and 300 PSI are available. Only 5VDC .5-4.5 VDC signal transducers can be used.

Defr CT Enable	Select if the DEFR CT Amps input on the CC200 will be used for heater amperage monitoring.
Defr CT Scale	Select the high end amperage scale of the defrost CT (current transducer). Only 4-20mA signal CTs are supported.
Aux AI 1 Funct	Select an auxiliary AI function if there is a sensor installed.
Aux AI 2 Funct	Select an auxiliary AI function if there is a sensor installed.
Fan CT Scale	Select the fan current transducers high end amperage value if an aux AI is set to Fan CT. Only 4-20mA signal CTs are supported.
Offsets	An offset parameter is provided for each sensor for service purposes. For most situations no offset is required. Enter an offset if needed to calibrate the sensor.

11. Once AI Config parameters are set and saved, tap on the RO Config group. Set the value of each parameter according to the system requirements and recommended action shown below:

RO Config	
Parameter	Recommended Action
Aux RO Function	<p>Select a function for the relay labeled AUX RELAY on CC200 enclosure. The aux RO can be used as a backup for the other 4 fixed relay functions or for additional CC200 features. The options are:</p> <ul style="list-style-type: none"> Not Used Light Fan LLSV REFRIG RO Defrost Alarm = General alarm output if any alarm is active Door alarm = Door alarm output for walk in box door left open Satellite 1 = Satellite RO for direct E2E control
Active State	Each relay has an active state set if the relay should be energized or de-energized to turn on its controlled load.



12. Once RO Config parameters are set and saved, tap on the DI Config group. Set the value of each parameter according to the system requirements and recommended action shown below:

DI Config	
Parameter	Recommended Action
CC200 DI 1 Func.	Each CC200 and Expansion Module digital input has a selectable function: Not Used = No digital input wired or used Door = Door switch connected Service Shutdown = Service shutdown switch or button connected Dual Temp. = Dual temperature switch connected Defrost Term. = Defrost termination switch or input connected Motion = Motion sensor for case lighting control connected Leak Shutdown = Refrigerant leak shutdown input connected Satellite 1 = Satellite digital input for E2E, DI value is passed to E2E for use in supervisor controller Satellite 2 = Satellite digital input for E2E, DI value is passed to E2E for use in supervisor controller
CC200 DI 2 Func.	
CC200 DI 3 Func.	
CC200 DI 4 Func.	
Exp Mod 1 DI Func.	
Exp Mod 2 DI Func.	
Exp Mod 3 DI Func.	
Active State	

13. Once DI Config parameters are set and saved, tap on the AO Config group. Set the value of each parameter according to the system requirements and recommended action shown below:

AO Config	
Parameter	Recommended Action
AO 1 Function / AO2 Function	Select a function for CC200 AO1 if used: Not Used = No AO used or wired up Dimming = Light dimming AO signal Satellite 1 = Satellite AO for direct e2e control, E2E will control via network Satellite 2 = Satellite AO for direct e2e control, E2E will control via network
Dimming AO Sig	Select the signal type for the analog output function: 0-10VDC 4-20mA



Sat. 1 AO Sig	Select the signal type for the analog output function: 0-10VDC 4-20mA
Sat. 2 AO Sig	Select the signal type for the analog output function: 0-10VDC 4-20mA
Dim AO Invert	Select if the signal output should be inverted. Inverting the signal output will cause the AO to deliver max signal at 0% and min signal at 100%.
Sat. 1 AO Invert	Select if the signal output should be inverted. Inverting the signal output will cause the AO to deliver max signal at 0% and min signal at 100%.
Sat. 2 AO Invert	Select if the signal output should be inverted. Inverting the signal output will cause the AO to deliver max signal at 0% and min signal at 100%.

14. Once AO Config parameters are set and saved, tap on the BACnet Protocol group. Set the value of each parameter according to the system requirements and recommended action shown below:

BACnet Protocol	
Parameter	Recommended Action
MS/TP MAC	Enter a unique address number for the CC200 designated as the router. All non-router devices can leave this at the default value.
MS/TP Baud	Enter the baud rate used for the router device to communicate with E2E/supervisor controller. All non-router devices can leave this at the default value.
Rack ID	Enter the rack ID. This sets the refrigeration rack system ID which is used for calculating BACnet device ID. This must be set for every CC200 on the communication bus.
Circuit ID	Enter the circuit ID. This sets the refrigeration circuit ID which is used for calculating BACnet device ID. This must be set for every CC200 on the communication bus.
Case ID	Enter the case letter. This sets the case letter ID which is used for calculating BACnet device ID. This must be set for every CC200 on the communication bus.
Max Master	Enter the max master for BACnet MS/TP. This must be set to the highest address between the supervisor and the router CC200.
APDU Retries	Leave factory default.
APDU Timeout	Leave factory default.
Max Info Frames	Leave factory default.

Router Enable	This must be set to yes for the CC200 designated as the router device. Only a single CC200 per communication bus needs to be set as the router device, all others should set this parameter to No.
---------------	--

11. Technical Specifications and Part Numbers

11.1. CC200 Case Controller Specifications

Name	Description
Power Requirements	24VDC 71(Earth) - 72(+) - 73(-)
Serial Port	RS485 Port B: Master/slave, 1/8 load, up to 115.2K Baud, isolated; generic 150-ohm termination with switch. 3-Terminal connector with onboard 100-ohm between RS485 “C” Terminal and RS485 isolated ground to allow direct earth ground connection. The RS485 Port B Gnd is isolated from RS485 Port A Gnd and all other circuit and earth grounds.
Enclosure	Type: 10 DIN Rail Mountable with CT
Dimensions	110mm x 183mm (4 5/16” x 7 3/16” x L)
Mounting	DIN Rail
ETH1	BACnet TCP/IP repeater (Ethernet 10/100)
ETH2	BACnet TCP/IP repeater (Ethernet 10/100)
Operating Temperature	14°F to 122°F (-10°C to 50°C)
Relative Humidity	20 to 85% RH; non-condensing
Relay Outputs	Form C (5 outputs) Load Limit: Fan CT relay is limited to 5A
Analog Inputs	Temperature (4 inputs) Pressure (1 input) DEF CT AMPS (1 input) AUX Inputs (2 inputs)
Digital Inputs	Dry Contact (4 inputs)
Analog Outputs	0 to 10 VDC or 4-20mA (2 outputs)
Stepper Valve	Bipolar or Unipolar
TRIAC (PWM Valves)	24/120/230Vac, 40VA Max
Remote Display	CC200 Case Display

11.2. CC200 Power Supply Specifications

Name	Description
Primary Power	120VAC
Secondary Power	24VDC
CC200 Power Requirements	24VDC 60W
Required Power Supply	CC200 Power Supply <i>Emerson P/N 810-3183</i>
Power Supply Terminals	2 (-V) & 3 (+V)
CC200 Power Terminals	72(+) --73(-) -- 71(Earth)
Wire Spec	16AWG
Max Wire Length	20"
Mounting	DIN Rail Mounted
Power Supply Dimensions	2.06" x 3.54" x 2.14" (W x H x D)

**Note: If the CC200 system has three (3) expansion modules, the 92W P/N 810-3184 power supply is required*

11.3. CC200 Case Expansion Module Specifications

Name	Description
Operating Temperature	14°F to 122°F (-10°C to 50°C)
Relative Humidity	20-85% RH; non-condensing
Enclosure	Type: 4 DIN Rail Mountable Rating: UL 94V-0
Dimensions	110mm x 183mm (4 5/16" x 7 3/16")

11.4. CC200 Case Display Specifications

Name	Description
Power Requirement	Powered from the CC200 Case Controller
Required Wire	Belden #8871 3C22awg or Belden #8772 3CC22awg
Physical Dimensions	Refer to Quick Start Guide
Mounting Dimensions	Refer to Quick Start Guide
Mounting	Use the white sliding clips that are provided with the CC200 Display
Operating Temperature	-4°F to 131°F (-20°C to 55°C)
Relative Humidity	20 to 85 RH% (non-condensing humidity)
Protection	Body: IP20; Front: IP66



Points	CC200 Terminals to CC200 Display Terminals
-	27(-) to 5(-)
+	28(+) to 4(+)
VNR	29(VNR) to 3(VNR)

11.5. Part Numbers for Ordering

*Emerson Part Number	Description
810-3180	CC200 Main Controller
810-3181	CC200 Expansion Module
810-3182	CC200 Power Supply
810-3183	CC200 Case Display
810-3184	CC200 Power Supply, 24VDC, 3.83A, 92W, DIN Mount <i>*Note: If the CC200 system has three (3) expansion modules, the 92W 810-3184 power supply is required.</i>
501-1122	Discharge Air Temperature Sensor
501-1127	Defrost Termination Temperature Sensor
501-1128	Return Air Temperature Sensor
501-1125 (blue) 501-1126 (red)	Coil Out Temperature Sensor
800-2100	100lb Pressure Transducer
261-0001	CT Defrost/Fan CT, 20A (4-20mA)
261-0002	CC200 Walk In Defrost CT, 50A (4-20mA)
302-0100	CC200 Case Display Bracket <i>*Note: For use with 810-3182 CC200 Case Display</i>

**For optimal performance of the CC200, Emerson parts are required.*

12. CC200 Installing the Update Package

12.1. CC200 Application – Installing the update Package

1. Use UltraSite

- a. Connect to the E2 through UltraSite.
- b. Right click on the E2 unit, select **Service Action** and **Package Transfer**.
- c. Locate and select the update .PKG file.
- d. Wait for transfer to E2 to complete.

2. For A Case (Router) Units

- a. On the E2 access the CC200 routers application (Menu-5, then select the A case for the lineup).
- b. On the CC200 A case Status screen press Enter to bring up the menu.
- c. Select **Application Commands**.
- d. Select **Fw Updt Cancel Transfer** to clear out any previous updates.
- e. Select **Rfc FW Updt Transfer**.
 - i. Check for “Validating Package” message in E2 System Update Log (Menu-7-3-5-3-2).
 - ii. Watch for “Completed” message in E2 System Update Log.
 1. Firmware transfer can take 15 minutes to complete from E2 to CC200 A case.
- f. Once transfer is completed according to the E2 System Update Log, select **Rfc Inst Fw Updt**.
 - i. The CC200 reads the update file.
 1. The USB LED and LED 1 will go solid orange for a few seconds.
 2. Then LED 1 will blink five (5) times.
 3. The CC200 will reboot.
 - ii. Verify that the update was applied by checking the CC200 version on the Network Summary screen (Menu-7-7-1).
 1. If the update was successful, proceed to **Step 3**.
 2. If the update was unsuccessful, return to **Step 2** and reattempt the update.
 - a. Ensure **Step 2, d. Fw Updt Cancel Transfer** is used to clear out the failed update.

3. Update any remaining cases in the lineup using Step 2 above while noting the following:

- a. Selecting **Rfc FW Updt Transfer** on the remaining cases in the lineup will transfer the update file from the A case CC200 itself instead of the E2 unit.
 - i. Update transfer time from the A case to the other cases is reduced to a few seconds.

12.2. CC200 PIC Firmware - Installing the update package

1. Use UltraSite

- a. Connect to the E2 through UltraSite.
- b. Right click on the E2 unit, select **Service Action** and **Package Transfer**.
- c. Locate and select the update .PKG file.
- d. Wait for transfer to E2 to complete.

2. For A case (Router) Units

- a. On the E2 access the CC200 routers application (Menu-5, then select the A case for the lineup).
- b. On the CC200 A case Status screen press Enter to bring up the menu.
- c. Select **Application Commands**.
- d. Select **Fw Updt Cancel Transfer** to clear out any previous updates.
- e. Select **Rfc FW Updt Transfer**.
 - i. Check for **Validating Package** message in E2 System Update Log (Menu-7-3-5-3-2).
 - ii. Watch for **Completed** message in E2 System Update Log.
- f. Once transfer is completed according to the E2 System Update Log, select **Rfc Inst Fw Updt**.
 - i. The CC200 reads the update file and extracts the Firmware update.
- g. On the E2 access the CC200 routers application (Menu-5, then select the A case for the lineup).
- h. On the CC200 A case Status screen press Enter to bring up the menu.
- i. Select **Application Commands**.
- j. Select **Start PIC FW** to begin the CC200 Firmware update.
 - i. The Firmware update will be applied.

3. Update any remaining cases in the lineup using Step 2 above while noting the following:

- a. Selecting **Rfc FW Updt Transfer** on the remaining cases in the lineup will transfer the update file from the A case CC200 itself instead of the E2 unit.
 - i. Update transfer time from A case to the other cases is reduced to a few seconds.

Appendix A: CC200 Case Controller Hardware and Wiring Quick Start Guide

Functions of the CC200

- Low, medium, and dual temperature case types supported.
- Stepper Valve Driver Onboard.
- EEPR control based on pressure or temperature.
 - New patent pending floating evaporator SST setpoint management automatically adjusts evaporator SST to the optimum setpoint for discharge air.
- Case Display with touchscreen.
- Form C relays allow direct control of case loads and simplified wiring.
- Simplified wiring and connections reduce labor and setup time.
- Bluetooth® connectivity for easy controller status and service.

CC200 Main Controller Specifications



Name	Description
Power Requirement	24Vdc 71(Earth) - 72(+) - 73(-)
Mounting	DIN Rail
Dimensions	7 3/16"x 4 5/16"x 3" (W x H x D)
Serial Port	Master/slave, 1/8 load, up to 115.2K Baud, isolated; generic 150-ohm termination with switch. 3-Terminal connector with onboard 100-ohm between RS485 "C" Terminal and RS485 isolated ground to allow direct earth ground connection. The RS485 Port B Gnd is isolated from RS485 Port A Gnd and all other circuit and earth grounds.
ETH1	BACnet TCP/IP repeater (Ethernet 10/100)
ETH2	BACnet TCP/IP repeater (Ethernet 10/100)
Operating Temperature	14°F to 122°F (-10°C to 50°C)
Relative Humidity	20-85% RH; non-condensing

Power Supply Wiring and Specifications

Power Supply Specifications	
Primary Power	120Vac
Secondary Power	24Vdc
CC200 Power Requirement	24VDC 60W
Required Power Supply*	CC200 Power Supply 24DC 60W Emerson P/N 810-3183
Power Supply Terminals	2 (-V) & 3 (+V)
CC200 Power Terminals	72(+) --73(-) -- 71(Earth)
Wire Spec	16AWG
Max Wire Length	20"
Mounting	DIN Rail Mounted
Power Supply Dimensions	2.06" x 3.54" x 2.14" (W x H x D)

NOTICE

If the CC200 system has three (3) expansion modules, the 92W P/N 810-3184 power supply is required.

1. Step 1: Mount Power Supply and CC200 Main Controller to DIN Rail.
2. Step 2: Wire Secondary power from Power Supply to CC200 Main Controller.
 - a. Reference specification and drawing for Terminals.
 - b. This is Polarity Sensitive.
3. Step 3: Wire Primary power to Power Supply.
 - a. Reference the specification and drawing for Terminals.

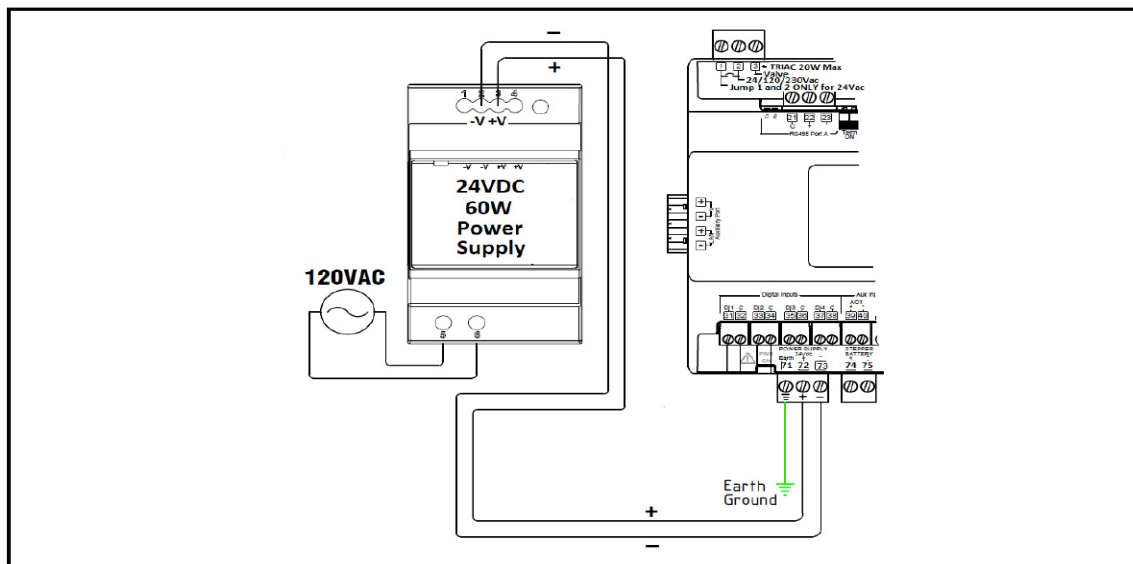

CC200 Main Controller Output Wiring

1. Step 1: Verify power is OFF on the CC200 Main Controller.
2. Step 2: Refer to the specification drawing below for the correct termination terminals and how to wire:

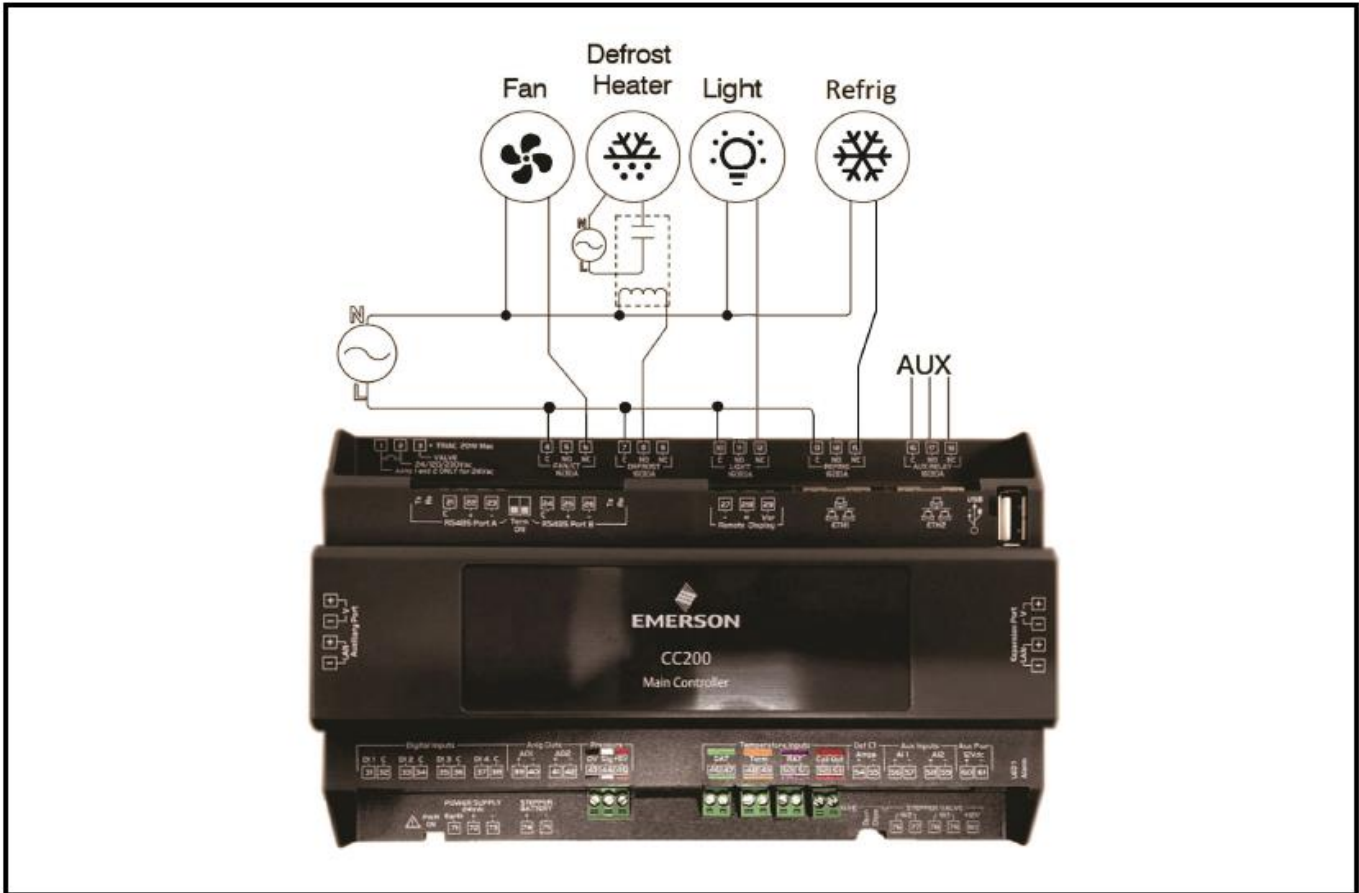

For Fan Motors Over 5A

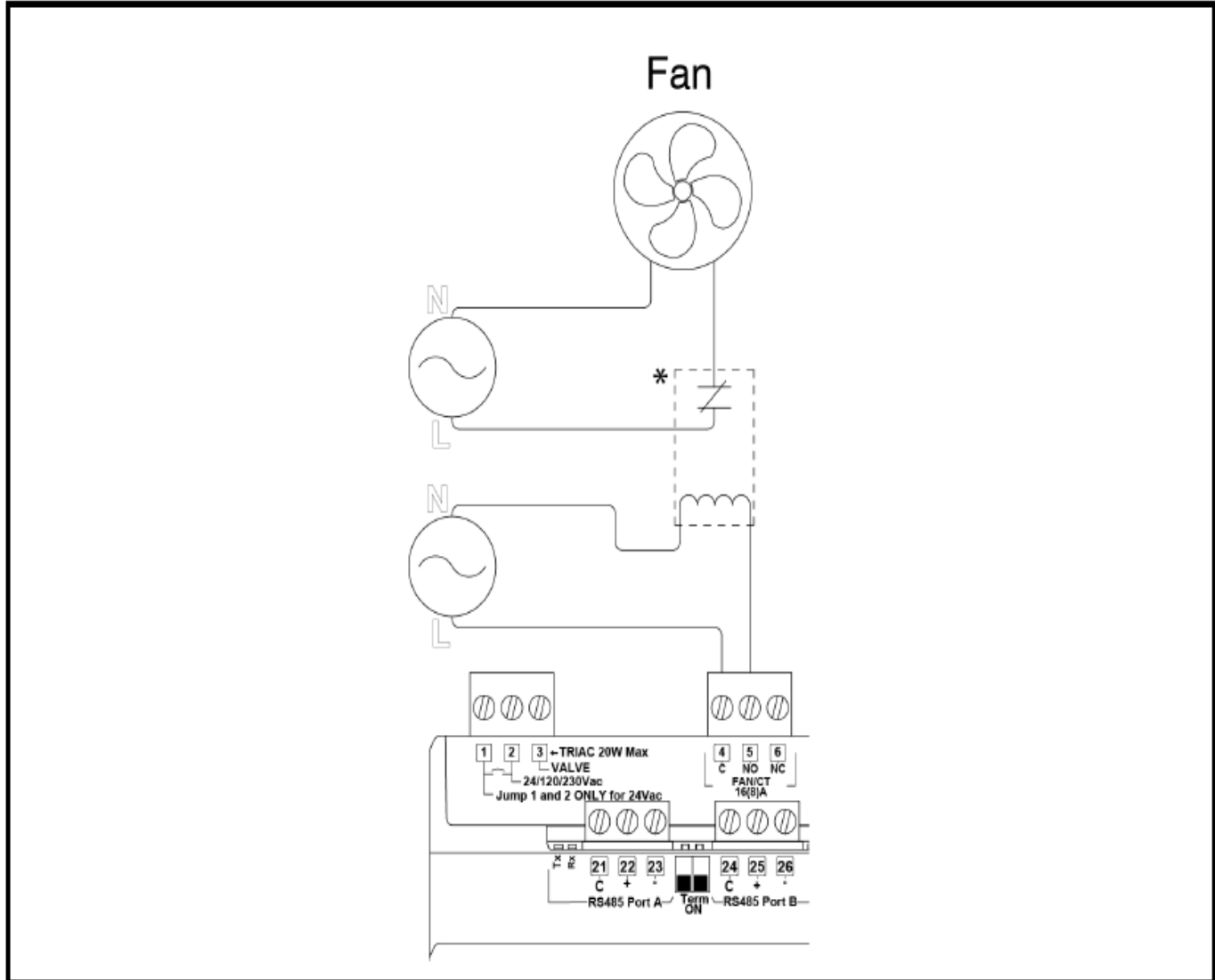



CC200 Main Controller Output Specification

Power Supply Specifications			
CC200 Label	AMP/VAC	LOADS CONTROLLED	TERMINALS
Fan/CT (RO)	Form C Relay with built in CT: NO: Resistive 5A, 240Vac or less; 5FLA, 30LRA, 240Vac or less; Pilot Duty B300 NC: Resistive 5A, 240Vac or less; 5FLA, 30LRA, 240Vac or less; Pilot Duty C300	Evap Fans	4(C) – 5(NO) – 6 (NC)
Defrost (RO)	Form C Relay	Defrost Heaters	7(C) – 8(NO) – 9(NC)
Light (RO)	NO: Resistive 12A, 240Vac or less; 10FLA, 60LRA, 240Vac or less; Pilot Duty B300 NC: Resistive 12A, 240Vac or less; 5FLA, 30LRA, 240Vac or less; Pilot Duty C300	Case Lights	10(C) – 11(NO) – 12(NC)
Refrig (RO)		LLSV	13(C) – 14(NO) – 15(NC)
AUX (RO)		Alarm Out, Door Alarm, Satellite for E2E control, backup for other RO	16(C) – 17(NO) – 18(NC)
AO1 (AO)	4-20mA or 0-10Vdc	Satellite for E2E control, future Light Dimming, future Anti- sweat	39(+) – 40(-)
AO2 (AO)	4-20mA or 0-10Vdc	Future Light Dimming	41(+) – 42(-)



CC200 Main Controller Input Specifications

Input Specifications		
CC200 Label	Description	Terminals & Color
DAT	Discharge Air	46 – 47 <i>Green</i>
TERM	Defrost Termination	48 – 49 <i>Orange</i>
RAT	Return Air	50 – 51 <i>Purple</i>
COIL OUT	Coil Out	52 – 53
PRESSURE	100lb, 150lb, 200lb, and 300lb Pressure Transducer Polarity sensitive	43(0v) – 44(Sig) – 45(+5V) Black – White – Red
Def CT Amps	Defrost Amps (electric defrost only)	54(+) – 55(-)

Aux Inputs AI & DI		
AI1 AI2	Configurable functions: External fan CT, Coil Inlet Temp, Product Temp, Circuit Suction Temp	56(+) – 57(-) 58(+) – 59(-)
DI1 DI2 DI3 DI4	Door switch, service switch, dual temp switch, defrost term switch, leak shutdown, satellite 1 for E2E, satellite 2 for E2E	31(DI1) – 32(C) 33(DI2) – 34(C) 35(DI3) – 36(C) 37(DI4) – 38(C)

Wire Specifications for extending Input and Valves	
Analog Temp Sensors or Digital Inputs	General Cable 92454A <i>Emerson P/N 135-0600</i> or Belden 8761 <i>Emerson P/N 035-0002</i> or equivalent 2 conductor shielded 22 AWG or larger cable may be used to extend length to a maximum of 50 ft. If manufacturer harness must be extended, join wires with heat shrink and solder.
Pressure Transducer	Belden 28326AS <i>Emerson P/N 135-2832</i> or Belden 8771 <i>Emerson P/N 135-8771</i> or equivalent 3 conductor shielded 22 AWG or larger cable may be used to extend length to a maximum of 50 ft. If manufacturer harness must be extended, join wires with heat shrink and solder.

CC200 Input Wiring

1. Step 1: Make sure the power is OFF to the CC200 Main Controller.
2. Step 2: Determine what sensors will be needed and wire per the specification below.
 - a. If sensor need to be extended Emerson only supports heat shrink and solder.
3. Step 3: Determine how many coils are on the cases.
 - a. For multi-coil cases the CC200 supports one sensor per coil for discharge air, return air, defrost termination and coil outlet. Pressure transducers for multi-coil cases may be installed one per coil or one for the entire case (parameter selectable).
 - b. For multi-coil cases the sensors on coil #1 will terminate on the CC200 Main Controller. Second and third sensor coils will require an Expansion Module per coil and each coil's sensor will terminate on the each of the Expansion Modules.

CC200 Main Controller Input Wiring

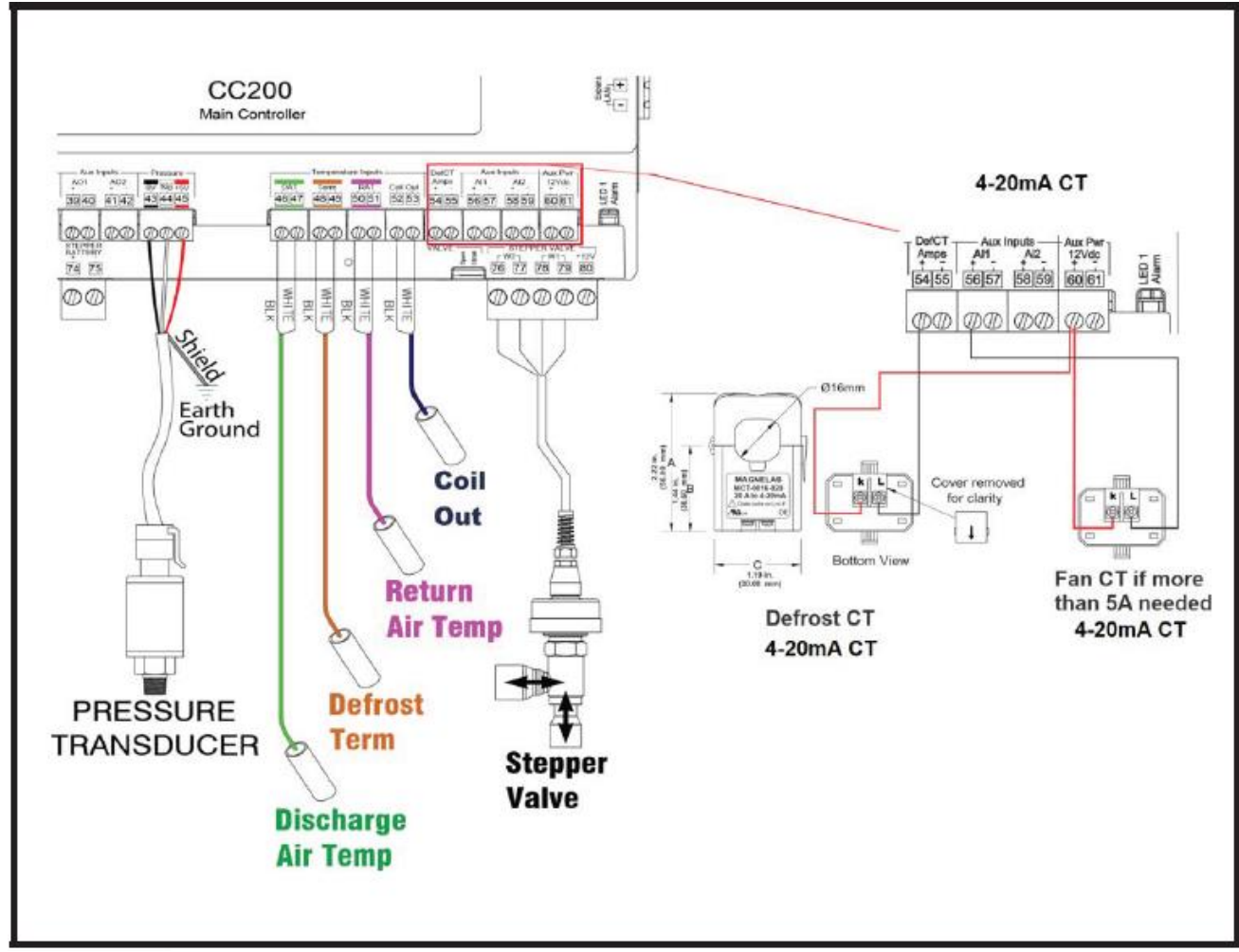

Coil Outlet Sensor Mounting

For proper superheat monitoring and control, the coil outlet sensor is required to make the superheat calculation. The coil outlet sensor must be mounted on a clean, straight, horizontal oriented piece of suction pipe. Ideally no more than 16 inches from the exit of the evaporator coil housing. The sensor probe must be tightly secured to the suction pipe in the 4 or 8 o'clock position with two heavy duty zip ties. Once secured the sensor should be insulated well with black cork tape insulation or equivalent adhesive insulation.

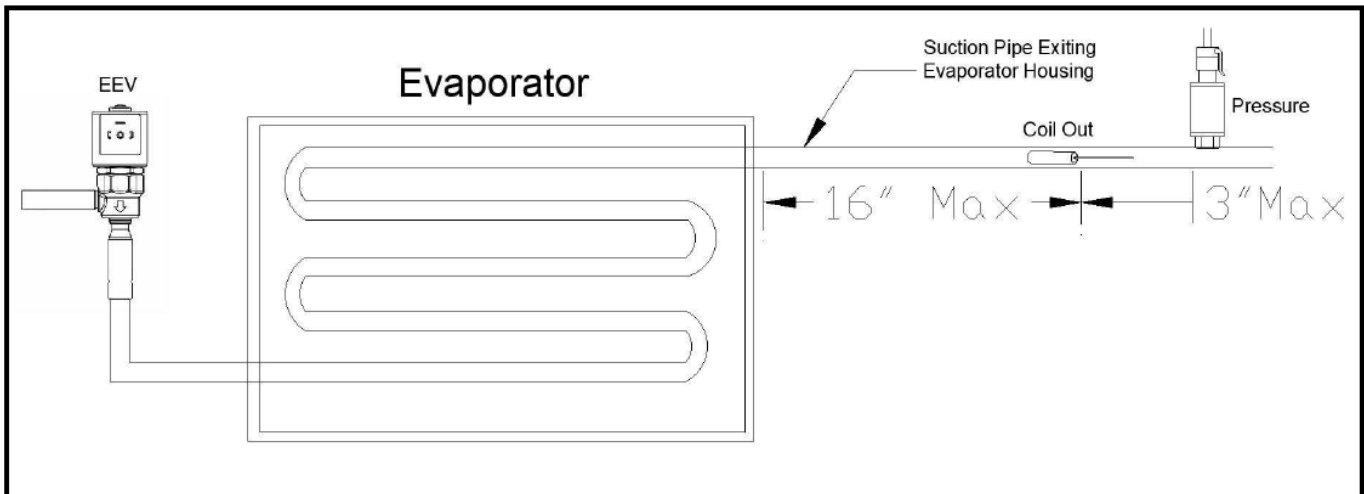
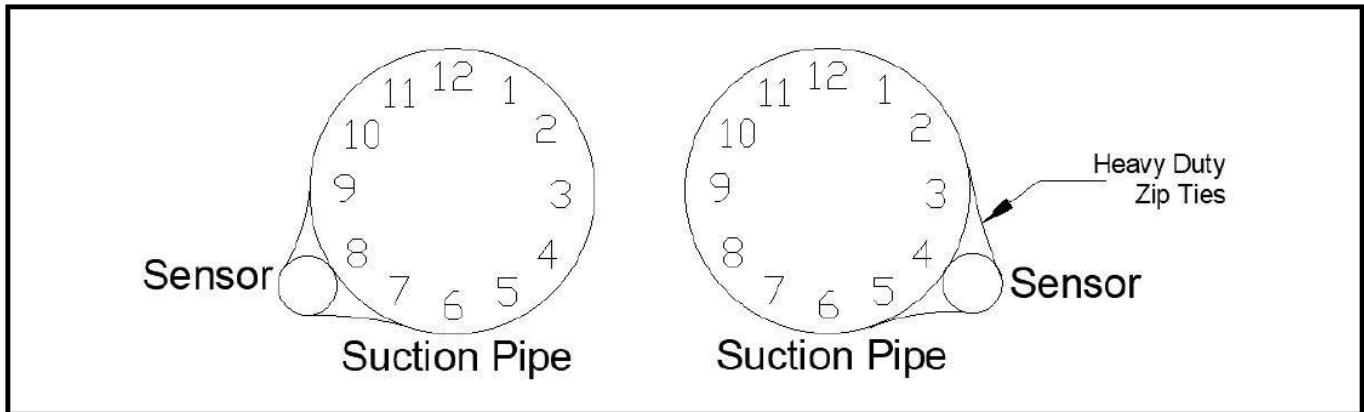

Pressure Transducer Mounting

For proper superheat monitoring and control the pressure transducer is required to make the superheat calculation. The pressure transducer must be mounted on a clean, straight, horizontal oriented piece of suction pipe. Install the transducer in the 12 o'clock position on the suction pipe no more than 3 inches from the coil outlet sensor location.

EEV and EEPR Location

The CC200 Case control system (Main Controller + Expansion Modules) supports Electronic Expansion Valve (EEV) control using either Pulse Width Modulation (PWM) valves OR Stepper valves but NOT both. The first case in a CC200 lineup ('a' Case) has support for control of Electronic Evaporator Pressure Regulation (EEPR) stepper valve.

- PWM EEV 1 or Stepper EEV 1 is always located on CC200 Main Controller
- PWM EEV 2 or Stepper EEV 2 is always located on Expansion Module 1
- PWM EEV 3 or Stepper EEV 3 is always located on Expansion Module 2
- EEPR Location
 - When PWM EEV is used, EEPR is always located on CC200 Main Controller Stepper terminals
 - When Stepper EEV is used, EEPR is located on the last Expansion Module Stepper terminals

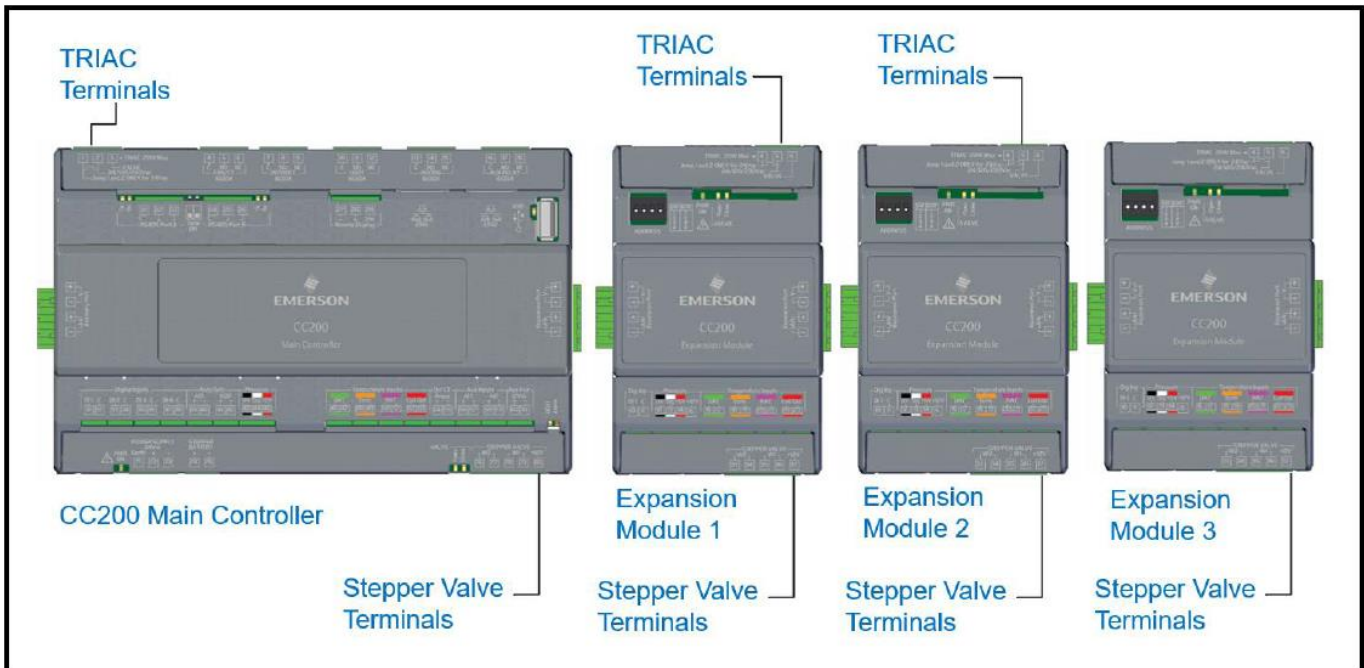

CC200 Stepper Valve Wiring

Bipolar Stepper Valve Connections

Refer to **EEV and EEPR Location** to determine the proper location for the valve. The CC200 Main Controller Stepper valve connections are made at the terminals labeled STEPPER VALVE using W1 and W2 (for Sporlan valve wire colors only) W2 (white=76, black=77) and W1 (red=78, green=79). The CC200 Expansion Module Stepper valve connections are made at the terminals labeled STEPPER VALVE using W1 and W2 (for Sporlan valve wire colors only), W2 (white=33, black=34), and W1 (red=35, green=36).

Wire Specifications for extending Stepper Valves

- EEV Stepper: Use the manufacturer harness with a maximum length not to exceed 40 ft (12 meters).
- EEPR Stepper (Bipolar): Belden 28326AS Emerson P/N 135-2832 or Belden 9418 Emerson P/N 135-9418 or equivalent 4 conductor shielded 18 AWG or larger cable may be used to extend length to a maximum of 75 ft. If manufacturer harness must be extended, join wires with heat shrink and solder.

Step 1: Make sure the power is OFF to the CC200 Main Controller and expansion module

- The wiring specification above is only for Sporlan Bipolar CDS valves or Sporlan SER EEV valves.
- If other manufacturer valves are used, refer to the manufacturer's specification and contact Emerson for instructions on how to terminate.

Step 2: Refer to the drawing and specification for termination of the valve:

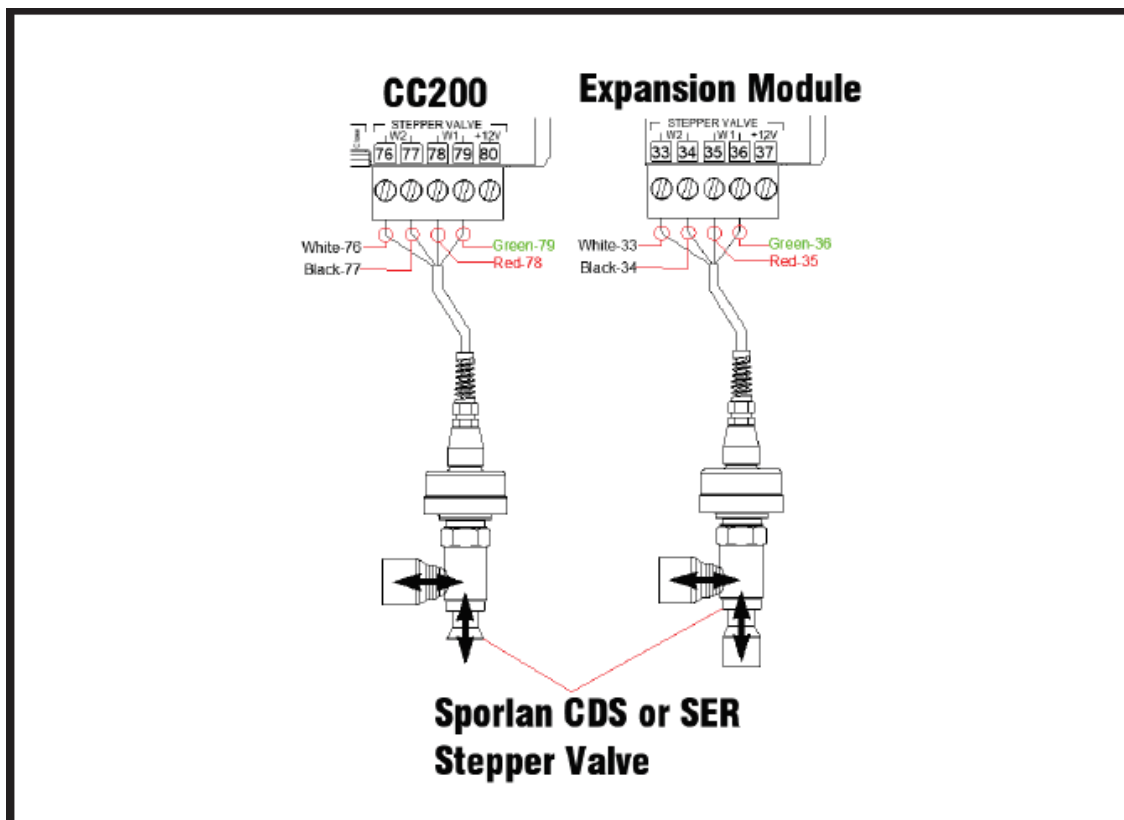

CC200 Stepper Valve Wiring and Specification

Stepper Valves (Sporlan CDS Only)		
Stepper Valve	Bipolar	W2
		76(White) – 77(Black)
		W1
		78(Red) – 79(Green)
Stepper Valve – Expansion Module	Bipolar	W2
		33(White) – 34(Black)
		W1
		35(Red) – 36(Green)
Wire Specs for Extending Inputs and Valves		
EEV Stepper	Use the manufacturer harness with a maximum length not to exceed 40 ft (12 meters).	
EEPR Stepper (Bipolar)	Belden 28326AS Emerson P/N 135-2832 or Belden 9418 Emerson P/N 135-9418 or equivalent 4 conductor shielded 18 AWG or larger cable may be used to extend length to a maximum of 75 ft. <i>If manufacturer harness must be extended, join wires with heat shrink and solder.</i>	

PWM EEV Wiring

Pulse Width Modulation EEV Connections

Refer to **EEV and EEPR Location** to determine the proper location for the PWM EEV valve.

Step 1: Power down the CC200 controller

Step 2: De-energize the supply power circuit that will power the PWM valve coil. Verify all wires and circuits are in an electrically safe work condition prior to performing any wiring.

Step 3: Refer to the below diagram for 120V valve coils only, complete the terminations as shown in the diagram. The PWM valve ground wire or terminal should be securely connected to 120VAC supply circuit ground. Do not connect PWM valve ground wire to any CC200 terminal.

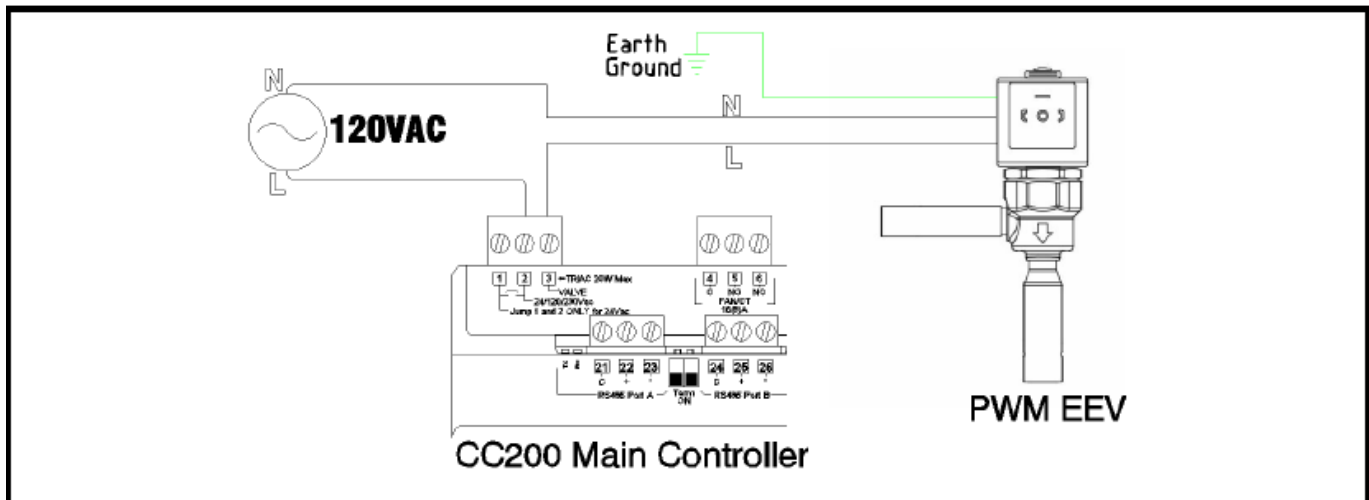

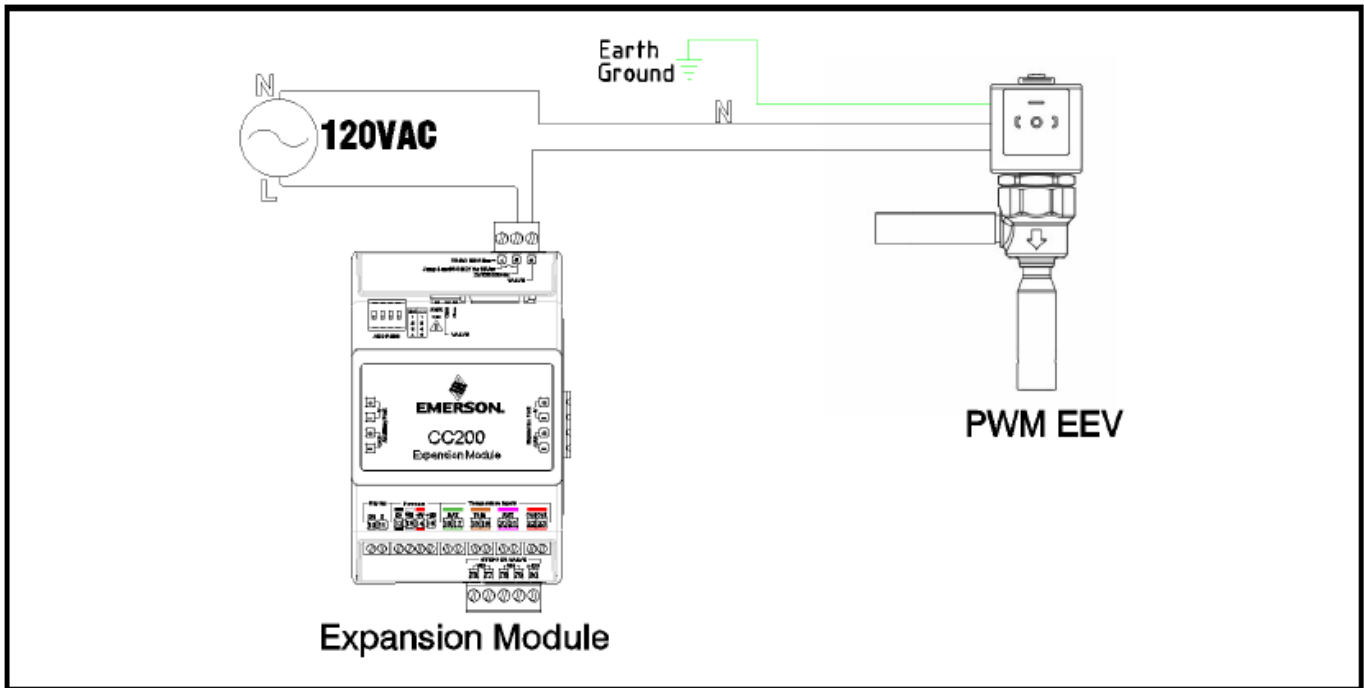

CC200 Expansion Module Mounting and Installation

Step 1: Determine if you need an Expansion Module.

- b. An Expansion Module should be added for a second or third coil. Each coil will have temp sensors and a transducer and will be wired to the respective Expansion Module.

Step 2: Addressing the Expansion Module

- a. Set the address of each Expansion Module using the ON/OFF dip switch bank on the top left corner of the hardware.
- b. Expansion Module one must be set to address 1 (Position 1 up), Expansion Module two to address 2 (Position 2 up), Expansion Module three to address 3 (Position 1 and 2 up).

Step 3: Install the Expansion Module.

- a. Make sure power is OFF to the CC200 Main Controller. Power will be restored in a later step.
- b. Install Expansion Module 1 on the DIN rail adjacent to the CC200's right side. The CC200 Expansion port terminals V+, V-, LAN+ and LAN- will be aligned with Expansion Module 1 Expansion port terminals. Slide the Expansion Module into the CC200 Expansion port so both device's Expansion port connectors fasten together.
- c. If Expansion Modules 2 and 3 are present, connect to Expansion Module 1's Expansion port using in the same manner described in the above step.

No wiring is needed between the CC200 Main Controller and CC200 Expansion Module. Power and communication are sourced from the CC200 Expansion port and passed through each Expansion Module Expansion port.

Step 4: Terminate sensors on the Expansion Module and refer to the drawing and specifications above for terminal numbers and how to terminate.

- a. Once all sensor terminations are complete and the Expansion Module Expansion port is securely plugged into the CC200 Expansion port, restore the 24VDC supply power to the CC200 Main Controller. Once connected, the Expansion Module PWR ON LED will illuminate green indicating supply power is present.

Connecting Two Expansion Modules and Termination

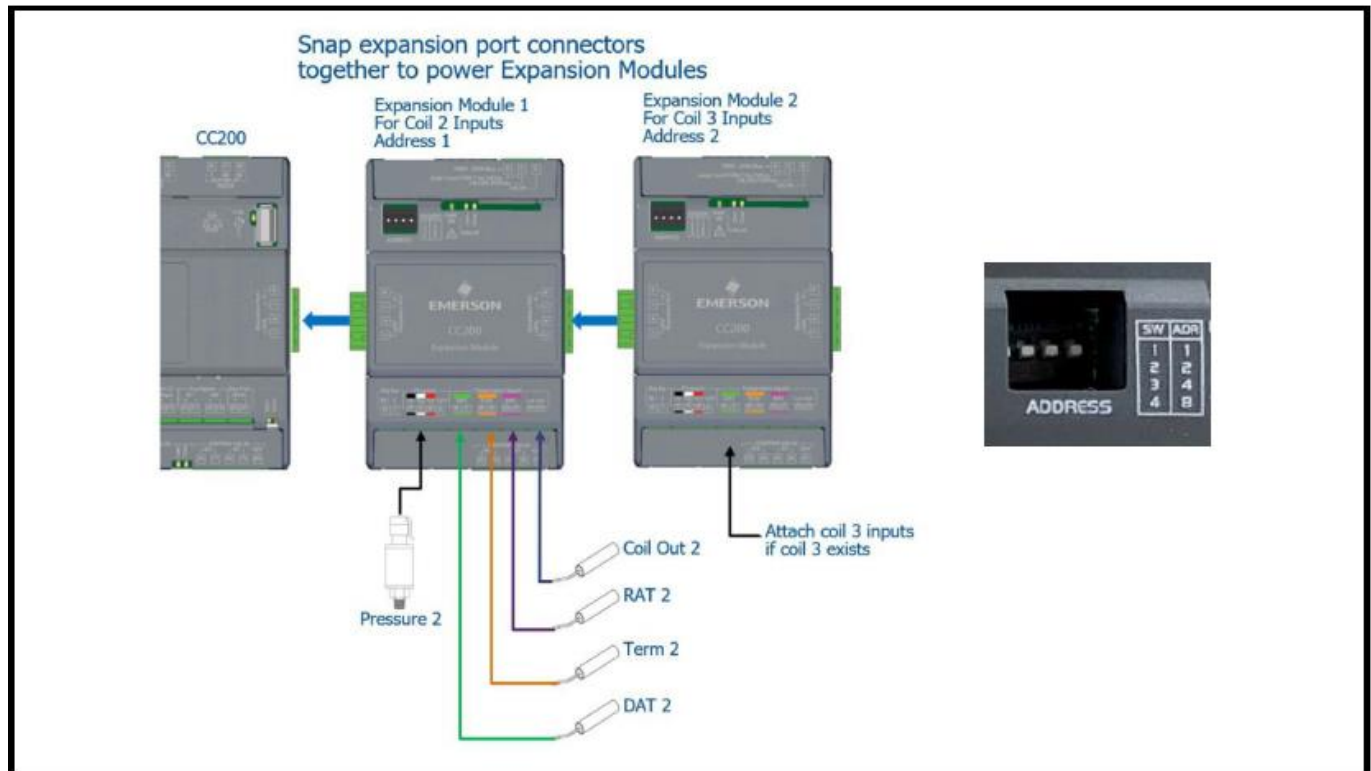



CC200 Expansion Module Wiring Specifications

CC200 Label	Description	Terminals & Color
DAT	Discharge Air	16 – 17 Green
TERM	Defrost Termination	18 – 19 Orange
RAT	Return Air	20 – 21 Purple
COIL OUT	Coil Out	22 – 23
PRESSURE	100lb, 150lb, 200lb, and 300lb Pressure Transducer <i>Polarity sensitive</i>	12(0v) – 13(Sig) – 14(+5V) Black – White – Red
Wire Specs for Extending Inputs and Valves		
Analog Temp Sensors or Digital Inputs	General Cable 92454A <i>Emerson P/N 135-0600</i> or Belden 8761 <i>Emerson P/N 035-0002</i> or equivalent 2 conductor shielded 22 AWG or larger cable may be used to extend length to a maximum of 50 ft. <i>If manufacturer harness must be extended, join wires with heat shrink and solder.</i>	
Pressure Transducer	Belden 28326AS <i>Emerson P/N 135-2832</i> or Belden 8771 <i>Emerson P/N 135-8771</i> or equivalent 3 conductor shielded 22 AWG or larger cable may be used to extend length to a maximum of 50 ft. <i>If manufacturer harness must be extended, join wires with heat shrink and solder.</i>	
EEV Stepper	Use the manufacturer harness with a maximum length not to exceed 40 ft (12 meters).	
EEPR Stepper (Bipolar)	Belden 28326AS <i>Emerson P/N 135-2832</i> or Belden 9418 <i>Emerson P/N 135-9418</i> or equivalent 4 conductor shielded 18 AWG or larger cable may be used to extend length to a maximum of 75 ft. <i>If manufacturer harness must be extended, join wires with heat shrink and solder.</i>	

CC200 Case Display Wiring

The C200 Case Display connection to the Case Controller is made with three (3) wire-cable from the CC200 Case Display port Terminals 27, 28, 29 labeled Remote Display to the CC200 Case Display terminals 3, 4 and 5 on the back of the display. The wire type used for this connection must be Belden #8771 3C22AWG or Belden #8772 3C20AWG or equivalent. Keep cable length at 50ft or less. Shield must not be connected to any terminal or earth ground (just inside the cable). Clip shield at both ends of cable and insulate with heat shrink.

	<p>CAUTION: Special care should be taken when making this connection so that no wires are incorrectly landed or crossed. Miswiring in this connection likely will result in damage to the Case Display.</p>
--	--

Step 1: Make sure power to the CC200 Main Controller is turned OFF.

Step 2: Make termination from the CC200 Main Controller to the CC200 Display.

- a. It is critical that these terminations are made correctly as this can result in damage to both devices if not terminated correctly.
- b. Clip and insulate shield at both ends of the Belden connection cable. Keep cable length at less than 50 ft (15 meters).

Step 3: Power ON the CC200 Main Controller.

Step 4: If supply power has been wired properly the display will boot up and illuminate all icons. The display will briefly show the characters **SYn** before showing the temperature readout. If a value of **Err** is shown, it simply means the air sensor is not wired to CC200 yet or is disconnected. A value of **noL** on the display indicates no communication, check the wiring between CC200 and the display and try again.

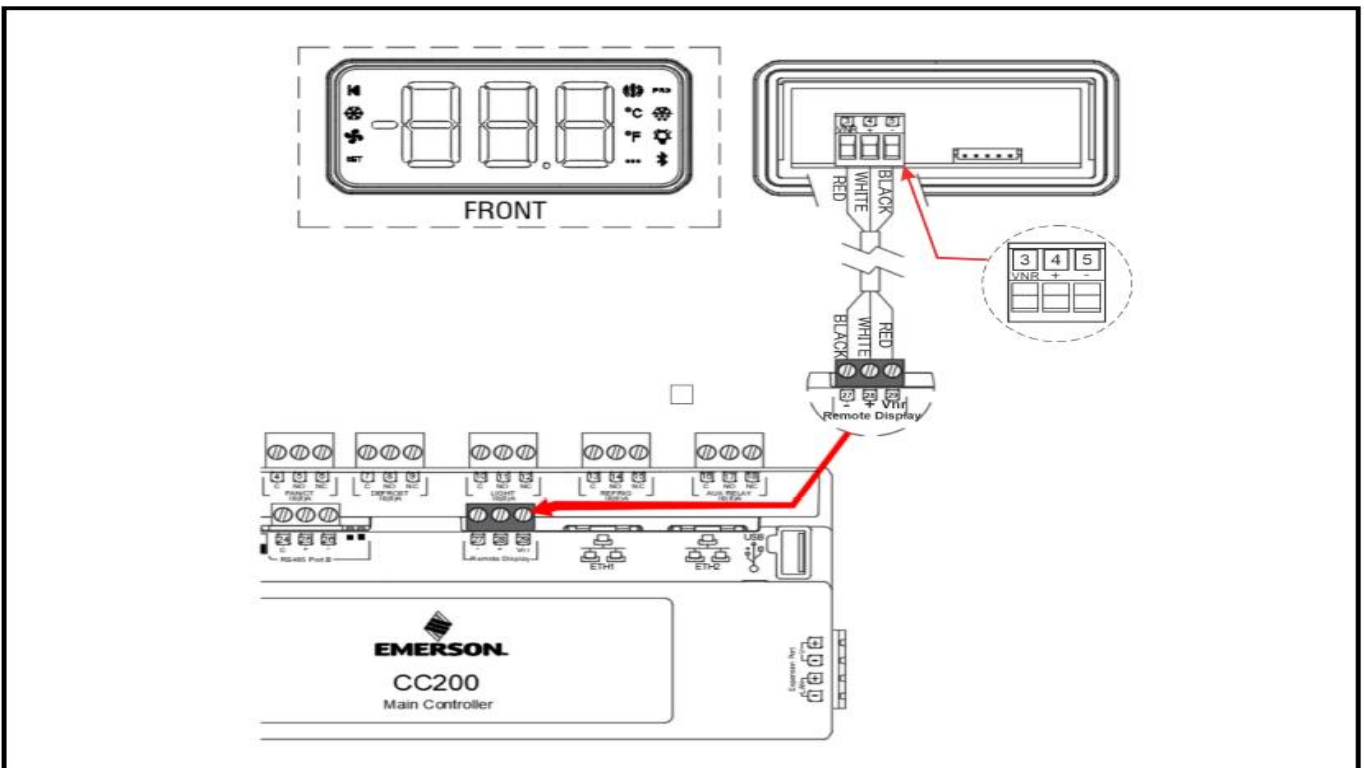
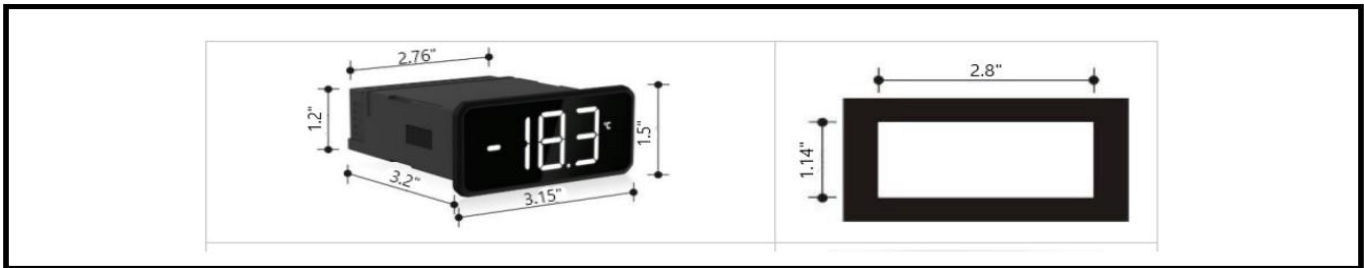

CC200 Bacnet IP Ethernet Cabling:

- TIA/EIA CAT5e or TIA/EIA CAT6 stranded pure copper conductors with wire size 24 AWG, 23 AWG, or 22 AWG.
- At a **minimum** the cable must meet 100-Ohm Balanced Twisted-Pair Cabling Standard ANSI/TIA/EIA-568-B.2 or
- ANSI/TIA-568-C.2.
- End connectors - RJ45 (8P8C) connector with same T568A or T568B wiring scheme at both ends of cable.
- T568B is the preferred wiring scheme for easier troubleshooting but T568A may be used if required by customer.
- Cable Jacket should be selected to meet local codes and voltage ratings for application.
- Shielded and unshielded twisted pairs cables are both acceptable.
- CC200 cabling segment maximum length 328 feet.

Appendix B: CC200 Parameters

PARAMETER NAME	DESCRIPTION	Unit	Min	Max	Group	List Option
MS/TP MAC	Enter the BACnet MS/TP mac of the controller	None	0	127	BACnet	
MS/TP Baud	Select the MS/TP baud rate for BACnet	List	1	5	BACnet	9600 19200 38400 57600 115200
Rack ID	Select the rack system ID for the case or lineup	List	1	58	BACnet	A, B, C, D, E, F, G, H, AS, BS, CS, DS, MT, MTA, MTB, MTC, MT1, MT2, MT3, MT4, MT5, LT, LTA, LTB, LTC, LT1, LT2, LT3, LT4, LT5, DT, DTA, DTB, DTC, DT1, DT2, DT3, RCU, SC, MS1, MS2, MS3, MS4,
Circuit ID	Select the circuit number for this lineup	None	1	99	BACnet	
Case ID	Select the case letter for this case	List	1	8	BACnet	
Max Master	Enter the BACnet max master of the controller	None	0	127	BACnet	
APDU Retries	Enter number of application protocol data unit retries	None	1	9	BACnet	
APDU Timeout	Enter application protocol or data unit timeout	Seconds	2	120	BACnet	
Max Info Frames	Enter max frames to send per token	None	1	50	BACnet	
Router Enable	Enable BACnet MS/TP to IP router	List	0	1	BACnet	No, Yes
Refrigerant	Selects the refrigerant gas type of the system	List	1	13	Sys. Setup	R-407A R-404A R-22 R-410A R-422D R-134a R-407C R-422A R-427A R-507A R-438A R-422C R-448A



Application Engineering **LUMITY**
B U L L E T I N

AE29-1455 R1

Expansion Valve Type	Select the expansion valve type installed	List	1	4	Sys. Setup	-TEV -TEV SH Monitor -EEV -PWM
Cases in Lineup	Specifies the number of cases in the refrigeration lineup	None	1	8	Sys. Setup	
Case Temp Mode	Select if the system is low, medium or dual temperature	List	1	3	Sys. Setup	Low Temp Med Temp Dual Temp
Number of Coils	Select the number of evaporator coils controlled by CC200	None	1	3	Sys. Setup	
Continuous Refrigeration	Specifies if LLSV should cut in/cut out with setpoint and deadband	List	0	1	Sys. Setup	No, Yes
LLSV Present	Select if a liquid line solenoid is wired to REFRIG relay output	List	0	1	Sys. Setup	No, Yes
Control Sensor	Select the type of air sensor used for temperature control	List	1	2	Sys. Setup	Discharge Air Return Air
Case Temp. Combination	Select the sensor combination method (avg, min, max)	List	1	3	Sys. Setup	Average Minimum Maximum
PWM Valve Period	Enter the period for the PWM valve	Seconds	1	12		
PWM Short Cycle	This is the PWM Valve minimum control % and prevents short cycle of valve by limiting the minimum ON time of Valve during the Pulse Period.	Percent	0	100		
Low Temp. Air Setpoint	Air temperature setpoint-low temp mode	DF	-99	99	Setpoints	
Medium Temp. Air Setpoint	Air temperature setpoint-med temp mode	DF	-99	99	Setpoints	
Air Setpoint Deadband	Refrigeration setpoint band (+/- half)	DDF	2	20	Setpoints	
Superheat Setpoint	Superheat control setpoint that all evaporators will be controlled to	DDF	2	20	Setpoints	
Superheat Deadband	Deadband around sh setpoint (+/- half)	DDF	0	20	Setpoints	
Max Pulldown Time	The maximum time allowed in pulldown	Minutes	0	120	Setpoints	
Door Disables Refrig.	Door opening disables refrigeration	List	0	1	Setpoints	No, Yes
Door Failsafe Timeout	Reactivate refrig. timeout when door is open	Minutes	0	120	Setpoints	
Heat Type	Defrost heat type: Electric, Off Cycle	List	1	2	Defrost	Electric Off Cycle
Defrost Start Time	Start time hour for first defrost of the day	None	0	23	Defrost	
	Start time minute for first defrost of the day	None	0	59	Defrost	
Cycles Per Day	The number of defrosts per day spaced evenly in 24 hours	None	1	12	Defrost	



Application Engineering **LUMITY**
B U L L E T I N

AE29-1455 R1

Termination Type	Select the method of defrost termination: time, temperature, digital input	List	1	3	Defrost	Time Temp DI
Termination Sensor	Select the sensor to use for defrost termination	List	1	3	Defrost	Defrost Term Discharge Air Coil Out
Term. Combination	Defrost termination sensor combination method	List	1	3	Defrost	Average Minimum Maximum
Term. Temp. Setpoint	Defrost termination temperature setpoint	DF	0	99	Defrost	
Minimum Time	The minimum time defrost must run before termination is allowed	Minutes	0	60	Defrost	
Maximum Time	Defrost maximum allowed run time	Minutes	5	120	Defrost	
Drip Time	Defrost evaporator drip time	Minutes	0	30	Defrost	
Pump Down Time	Pump down delay to remove liquid from evaporator	Minutes	0	20	Defrost	
Fan In Refrig.	Select the fan behavior during refrigeration cycle	List	1	2	Fan	Continuous On Cut In/Cut Out
Fan In Defrost	Select the fan behavior during defrost cycle	List	1	2	Fan	On In Defrost Off In Defrost
Delay Method	Method to delay fan after defrost	List	1	2	Fan	Time Delay Coil Temp
Delay Time	Time delay to reactivate fan	Seconds	0	600	Fan	
Delay Temp.	Coil out temp setpoint to reactivate fan	DF	-99	99	Fan	
ECM Present	Select if ECM fan motor is in use	List	0	1	Fan	No, Yes
Enable EEPR	Enable/disable EEPR control	List	0	1	EEPR	Disabled, Enabled
EEPR Motor Type	Stepper motor type: Unipolar, Bipolar	List	1	2	EEPR	Unipolar Bipolar
Control Mode	EEPR control mode: Discharge air, SST	List	1	2	EEPR	SST/Pressure Discharge Air
EEPR Cal. Method	EEPR valve calibration method	List	1	2	EEPR	Every Defrost First Defrost Only
Refrigerant Curve	Refrigerant curve type for SST control	List	1	4	EEPR	Dew Point 60/40 Avg Mid Point Bubble Point
Low Temp. SST Setpoint	Sat. suction temp. set in low temp mode	DF	-40	40	EEPR	
Med Temp. SST Setpoint	Sat. suction temp. set in med temp mode	DF	-40	40	EEPR	
Float Band	Band to float SST in, 0 disables float (only used in SST mode)	DDF	0	40	EEPR	
Max Steps	Maximum steps for EEPR stepper valve	None	0	10000	EEPR	
Step Rate	EEPR valve step rate (steps/second)	None	0	400	EEPR	



Over Close	Percentage of maximum steps to over drive during calibration	Percent	0	100	EEPR	
Relax Steps	Reverse steps after overclose EEPR	None	0	100	EEPR	
Minimum Opening	Reverse steps after overclose EEPR	Percent	0	100	EEPR	
Proportional	Proportional band for EEPR PID	DDF	2	100	EEPR	
P Band Offset	Band offset for EEPR PID regulation	DDF	-50	50	EEPR	
Integral	Integral for EEPR PID regulation	None	0	255	EEPR	
Derivative	Derivative for EEPR PID regulation	None	0	500	EEPR	
Derivative Time	Derivative time for EEPR PID regulation	None	0	500	EEPR	
EEV Cal Method	Select calibration method for EEV stepper	List	1	2	EEV	Every Defrost First Defrost Only
EEV 1 Motor Type	Valve motor type (Unipolar or Bipolar)	List	1	2	EEV	Unipolar Bipolar
EEV 2 Motor Type	Valve motor type (Unipolar or Bipolar)	List	1	2	EEV	Unipolar Bipolar
EEV 3 Motor Type	Valve motor type (Unipolar or Bipolar)	List	1	2	EEV	Unipolar Bipolar
Start Position	EEV1-3 position at beginning of regulation	Percent	0	100	EEV	
Start Hold Time	Time to hold EEV1-3 in start position	Seconds	0	1800	EEV	
EEV 1 Max Steps	Maximum steps of the valve	NA	0	10000	EEV	
EEV 1 Step Rate	Valve step rate (steps/seconds)	NA	0	400	EEV	
EEV 1 Overclose	Percentage of maximum steps to over drive during calibration	Percent	0	100	EEV	
EEV 1 Relax Steps	Steps to open after calibration procedure	NA	0	50	EEV	
EEV 1 Min Opening	Minimum opening allowed during regulation	Percent	0	100	EEV	
EEV 2 Max Steps	Maximum steps of the valve	NA	0	10000	EEV	
EEV 2 Step Rate	Valve step rate (steps/seconds)	NA	0	400	EEV	
EEV 2 Overclose	Percentage of maximum steps to over drive during calibration	Percent	0	100	EEV	
EEV 2 Relax Steps	Steps to open after calibration procedure	NA	0	50	EEV	
EEV 2 Min Opening	Minimum opening allowed during regulation	Percent	0	100	EEV	
EEV 3 Max Steps	Maximum steps of the valve	NA	0	10000	EEV	
EEV 3 Step Rate	Valve step rate (steps/seconds)	NA	0	400	EEV	
EEV 3 Overclose	Percentage of maximum steps to over drive during calibration	Percent	0	100	EEV	
EEV 3 Relax Steps	Steps to open after calibration procedure	NA	0	50	EEV	



EEV 3 Min Opening	Minimum opening allowed during regulation	Percent	0	100	EEV	
Control Mode	Select the lighting control strategy	List	1	5	Lights	-DI Triggers -Schedule w/Dim -Supervisor w/Dim -Local Schedule -Supervisor
Door Lights On	Lights switch ON when door is open	List	0	1	Lights	No, Yes
Motion Lights On	Lights switch ON when motion is detected	List	0	1	Lights	No, Yes
On Duration	Lights on duration for door or motion DI	Minutes	0	120	Lights	
Minimum Dim	Minimum light level for dimming logic	Percent	0	100	Lights	
Maximum Dim	Maximum light level for dimming logic	Percent	0	100	Lights	
Lights On Time	Hour of the time of day to turn the lights on	None	0	23	Lights	
	Minute of the time of day to turn the lights on	None	0	59	Lights	
Lights Off Time	Hour of the time of day to turn the lights on	None	0	23	Lights	
	Minute of the time of day to turn the lights on	None	0	59	Lights	
Temp. Alarm Hi	High case temperature alarm limit	DF	-99	99	Alarms	
Temp Alarm Low	Low case temperature alarm limit	DF	-99	99	Alarms	
Temp Alarm Delay	Minutes of alarm delay for hi/low case air temperature	Minutes	0	300	Alarms	
Temp. Delay After Def.	Minutes to delay temperature alarming after each defrost cycle	Minutes	0	300	Alarms	
Low SH. Alarm	Alarm setpoint for superheat	DDF	0	50	Alarms	
Low Sh. Alarm Delay	Time delay before activating the low superheat alarm	Minutes	0	120	Alarms	
Fan Proof On	Amperage value the fan motor must reach to be considered on	Amperes	0	25	Alarms	
Fan Proof Off	Amperage value the fan motor must reach to be considered off	Amperes	0	25	Alarms	
Fan Proof Delay	Delay time for fan proof alarm	Minutes	0	10	Alarms	
Defr. Proof On	Amperage level where defrost heater is considered on	Amperes	0	25	Alarms	
Defr. Proof Off	Amperage level where defrost heater is considered off	Amperes	0	25	Alarms	
Defr. Proof Delay	Delay time for defrost proof alarm	Minutes	0	10	Alarms	
Door Alarm Delay	Alarm delay for door left open	Minutes	0	300	Alarms	
Dat Config	Select discharge air configuration	List	1	2	AI Config	Not Used 1 Per Coil



Rat Config	Select return air configuration	List	1	2	AI Config	Not Used 1 Per Coil
Pressure Config	Select pressure transducer configuration	List	1	2	AI Config	Not Used 1 Per Coil
Pressure 1 Scale	Select high end EU for pressure 1	List	1	4	AI Config	100 PSI 150 PSI 200 PSI 300 PSI
Pressure 2 Scale	Select high end EU for pressure 2	List	1	4	AI Config	100 PSI 150 PSI 200 PSI 300 PSI
Pressure 3 Scale	Select high end EU for pressure 3	List	1	4	AI Config	100 PSI 150 PSI 200 PSI 300 PSI
Defr CT Enable	Selects if defrost CT is used/not used	List	1	2	AI Config	Disabled, Enabled
Defr CT Scale	Enter high end eu of defrost CT	Amperes	0	99	AI Config	
Aux AI 1 Funct	Select the function for aux. analog in 1	List	1	5	AI Config	Not Used Fan CT Coil Inlet Temp Product Temp Circuit Suct Temp
Aux AI 1 Funct	Select the function for aux. analog in 1	List	1	5	AI Config	Not Used Fan CT Coil Inlet Temp Product Temp Circuit Suct Temp
Aux AI 2 Funct	Select the function for aux. analog in 2	List	1	3	AI Config	Not Used Fan CT Circuit Suct Temp
Fan CT Scale	Enter high end eu of external fan CT	Amperes	0	50	AI Config	
Defr CT Offset	Sensor offset for Defrost C.T	Amperes	-5	5	AI Config	
Fan CT Offset	Sensor offset for Fan C.T.	Amperes	-5	5	AI Config	
DAT 1 Offset	Sensor offset for discharge air 1	DDF	-5	5	AI Config	
DAT 2 Offset	Sensor offset for discharge air 2	DDF	-5	5	AI Config	
DAT 3 Offset	Sensor offset for discharge air 3	DDF	-5	5	AI Config	
RAT 1 Offset	Sensor offset for return air 1	DDF	-5	5	AI Config	
RAT 2 Offset	Sensor offset for return air 2	DDF	-5	5	AI Config	
RAT 3 Offset	Sensor offset for return air 3	DDF	-5	5	AI Config	
Def Term 1 Offset	Sensor offset for Defrost Term evap 1	DDF	-5	5	AI Config	
Def Term 2 Offset	Sensor offset for Defrost Term evap 2	DDF	-5	5	AI Config	
Def Term 3 Offset	Sensor offset for Defrost Term evap 3	DDF	-5	5	AI Config	
Coil Out 1 Offset	Sensor offset for Defrost Term evap 1	DDF	-5	5	AI Config	



Coil Out 2 Offset	Sensor offset for Defrost Term evap 2	DDF	-5	5	AI Config	
Coil Out 3 Offset	Sensor offset for Defrost Term evap 2	DDF	-5	5	AI Config	
Pressure 1 Offset	Offset for pressure transducer evap 1	PSIG	-5	5	AI Config	
Pressure 2 Offset	Offset for pressure transducer evap 2	PSIG	-5	5	AI Config	
Pressure 3 Offset	Offset for pressure transducer evap 3	PSIG	-5	5	AI Config	
Liquid Temp. Off	Offset for liquid temperature	DDF	-5	5	AI Config	
Coil Inlet Offset	Sensor offset for coil inlet temp	DDF	-5	5	AI Config	
Product Offset	Sensor offset for product temperature	DDF	-5	5	AI Config	
Circ Suc. Offset	Sensor offset for circuit suction temp	DDF	-5	5	AI Config	
Aux RO Function	Select a function for auxiliary relay	List	1	8	Ro Config	Not Used Light Fan LLSV Defrost Alarm Door alarm Satellite 1
Fan RO Act	Select a state for the relay coil during logical true	List	0	1	RO Config	De-energize, Energize
Defrost RO Act	Select a state for the relay coil during logical true	List	0	1	RO Config	De-energize, Energize
Light RO Act	Select a state for the relay coil during logical true	List	0	1	RO Config	De-energize, Energize
Refrig RO Act	Select a state for the relay coil during logical true	List	0	1	RO Config	De-energize, Energize
Alarm RO Act	Select the active sate for alarm RO	List	0	1	RO Config	De-energize, Energize
Door Alm. RO Act	Select the active sate for door alm RO	List	0	1	RO Config	De-energize, Energize
Sat. 1 RO Act	Select the active sate for sat. 1 RO	List	0	1	RO Config	De-energize, Energize
CC200 DI1 Func.	Select digital input function-CC200 DI1	List	1	10	DI Config	Not Used Door Service Dual Temp. Defrost Term. Motion Leak Shutdown Satellite 1 Satellite 2

CC200 DI2 Func.	Select digital input function- CC200 DI2	List	1	10	DI Config	Not Used Door Service Dual Temp. Defrost Term. Motion Leak Shutdown Satellite 1 Satellite 2
CC200 DI3 Func.	Select digital input function- CC200 DI3	List	1	10	DI Config	Not Used Door Service Dual Temp. Defrost Term. Motion Leak Shutdown Satellite 1 Satellite 2
CC200 DI4 Func.	Select digital input function- CC200 DI4	List	1	10	DI Config	Not Used Door Service Dual Temp. Defrost Term. Motion Leak Shutdown Satellite 1 Satellite 2
Exp Mod 1 DI Func.	Expansion module 1 DI 1 function	List	1	10	DI Config	Not Used Door Service Dual Temp. Defrost Term. Motion Leak Shutdown Satellite 1 Satellite 2
Exp Mod 2 DI Func.	Expansion module 2 DI 1 function	List	1	10	DI Config	Not Used Door Service Dual Temp. Defrost Term. Motion Leak Shutdown Satellite 1 Satellite 2
Exp Mod 3 DI Func.	Expansion module 3 DI 1 function	List	1	10	DI Config	Not Used Door Service Dual Temp. Defrost Term. Motion Leak Shutdown Satellite 1 Satellite 2



Door DI Act	Select active state of door switch DI	List	0	1	DI Config	Off, On
Service DI Act	Select active state of service switch DI	List	0	1	DI Config	Off, On
Dual Temp DI Act	Select active state of Dual Temp DI	List	0	1	DI Config	Off, On
Def Term DI Act	Select active state of defrost term DI	List	0	1	DI Config	Off, On
Motion DI Act	Select active state of motion switch DI	List	0	1	DI Config	Off, On
Sat 1 DI Act	Select active sate of satellite 1 DI	List	0	1	DI Config	Off, On
Sat 2 DI Act	Select active sate of satellite 2 DI	List	0	1	DI Config	Off, On
Leak DI Act	Select active sate of leak shutdown DI	List	0	1	DI Config	Off, On
AO 1 Function	Select the function for analog out 1	List	1	4	AO Config	Not Used Dimming Satellite 1 Satellite 2
AO 2 Function	Select the function for analog out 2	List	1	4	AO Config	Not Used Dimming Satellite 1 Satellite 2
Dimming AO Sig	AO configuration (0..10V,4..20mA)	List	1	2	AO Config	0-10VDC 4-20mA
Sat. 1 AO Sig	AO configuration (0..10V,4..20mA)	List	1	2	AO Config	0-10VDC 4-20mA
Sat. 2 AO Sig	AO configuration (0..10V,4..20mA)	List	1	2	AO Config	0-10VDC 4-20mA
Dim. AO Invert	Invert dimming analog output signal	List	0	1	AO Config	No, Yes
Sat. 1 AO Invert	Invert sat 1 analog output signal	List	0	1	AO Config	No, Yes
Sat. 2 AO Invert	Invert sat 2 analog output signal	List	0	1	AO Config	No, Yes

Figure 1 Controller Image



Figure 2 Case Display Overview

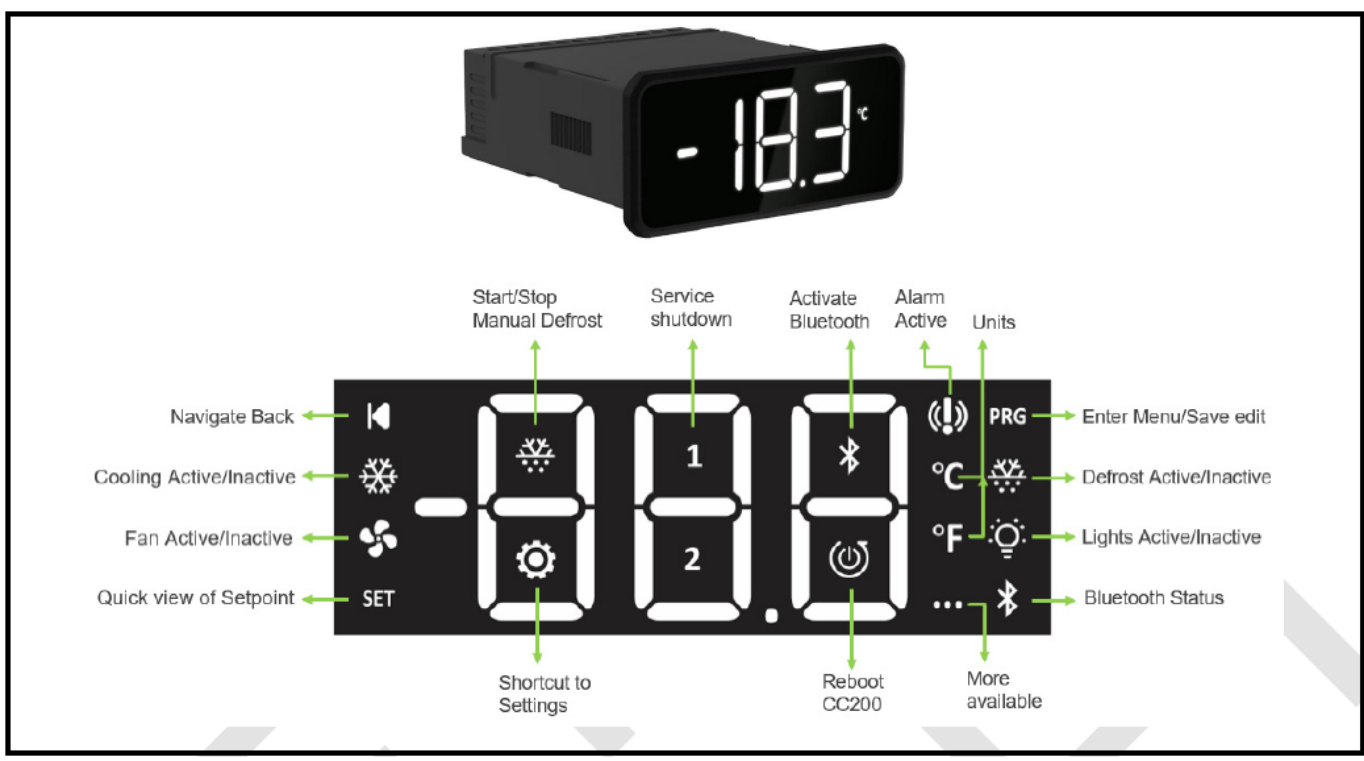

Figure 3 CC200 Wiring and Connections

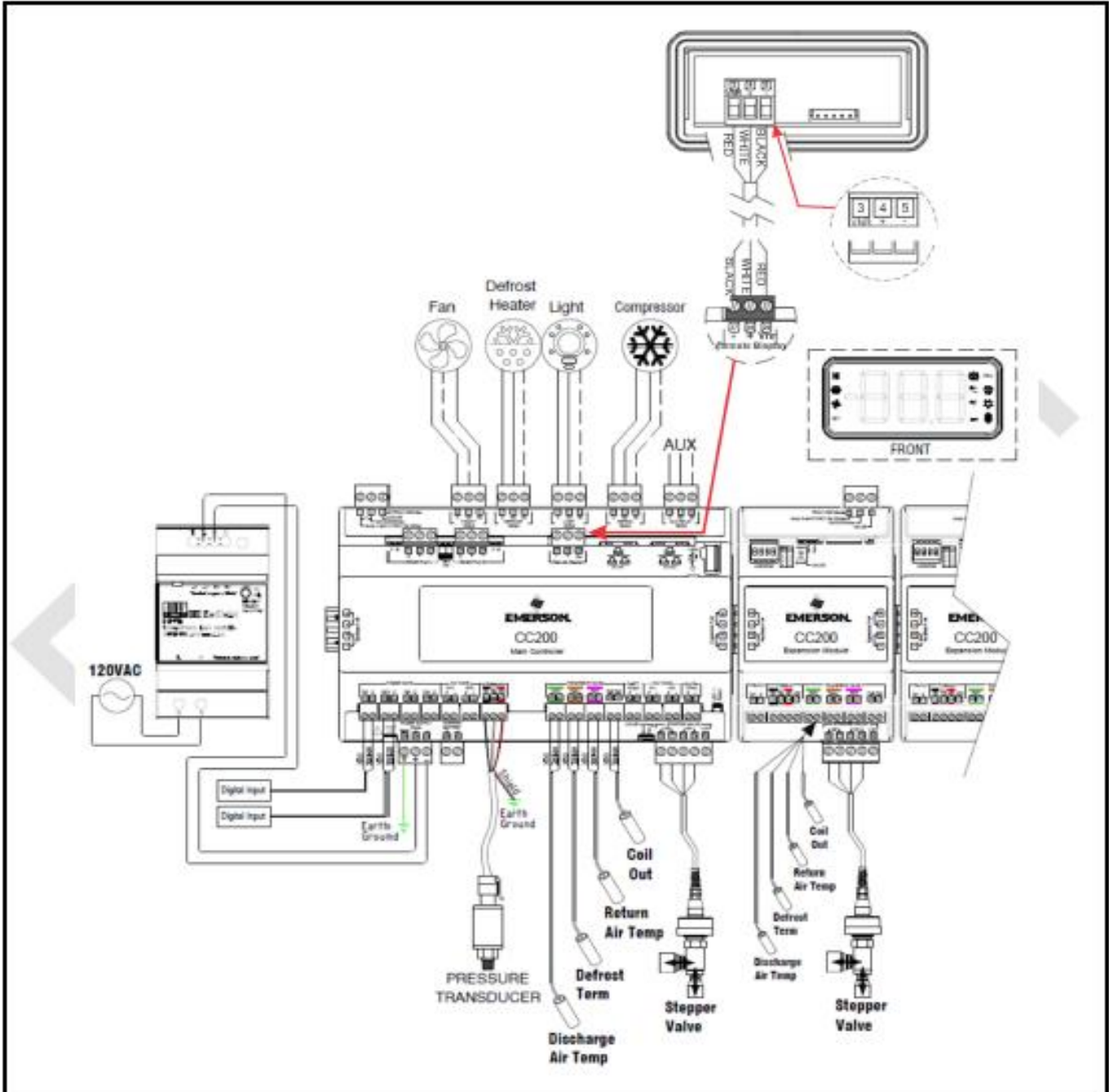

Figure 4 Network Topology Overview

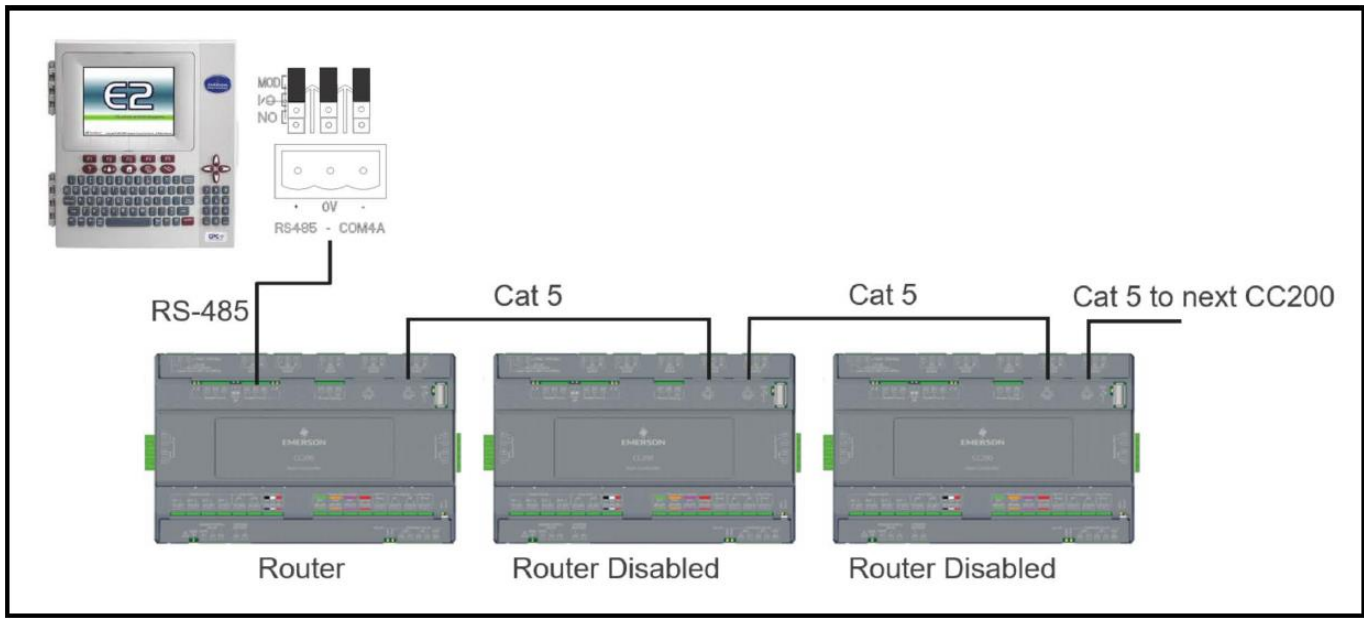

Figure 5 RS485 BACnet MSTP Network Wiring

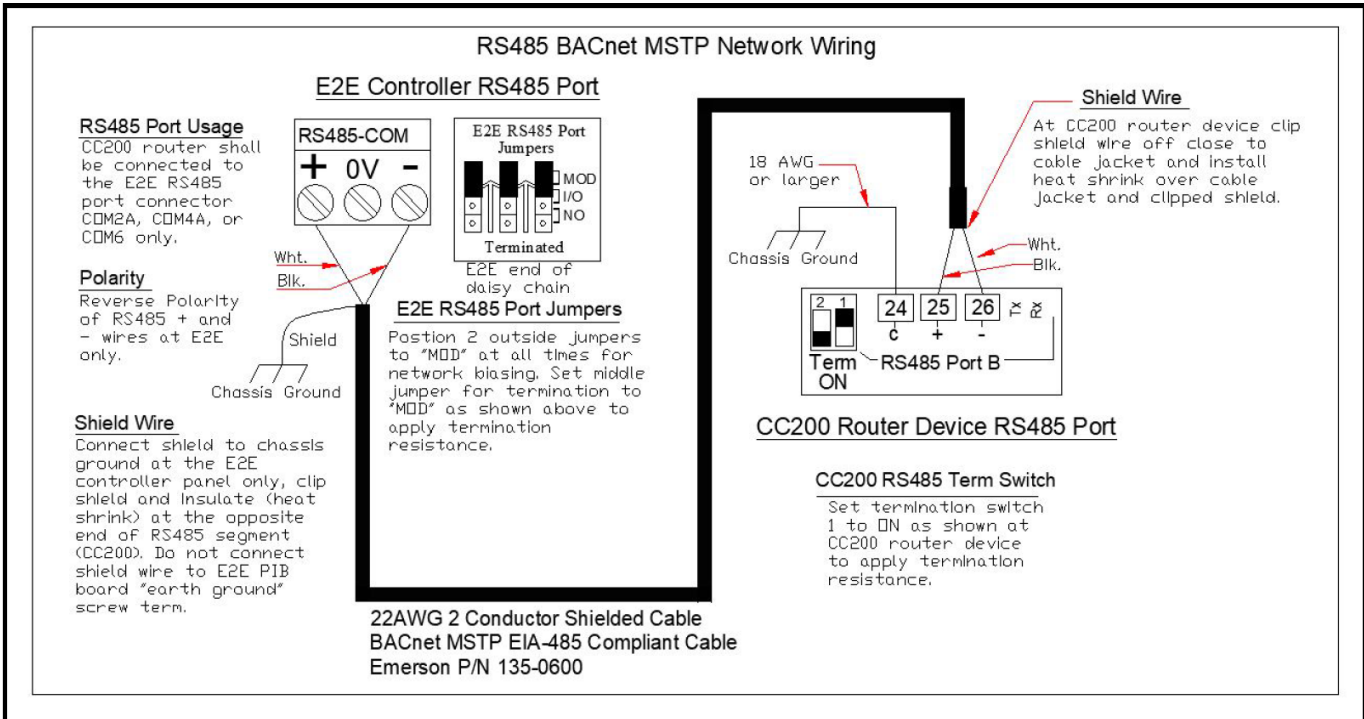



Table 1 CC200 Hardware Platform Parts





LEGEND		
Terminal	Label	Purpose
1-3	TRIAC	Connection of PWM expansion valve
4-6	FAN/CT	Fan control relay. Connection of evaporator fan motor or control point (contactor/pilot relay). Internal amperage monitors measures motor current.
7-9	DEFROST	Defrost control relay. Connection of defrost heater or control point (contactor/pilot relay).
10-12	LIGHT	Light control relay. Connection of case lights
13-15	REFRIG	Refrigeration control relay for connection of liquid line solenoid valve (if present).
16-18	AUX RELAY	Auxiliary control relay for spare or additional functions.
21-23	RS485 Port A	RS485 serial communications port
24-26	RS485 Port B	RS485 serial communications port for BACnet MS/TP connection to E2E
27-29	Remote Display	Connection for CC200 case display
NA	ETH1	RJ45 Ethernet 1 used for case lineup peer communication and BACnet IP
NA	ETH2	RJ45 Ethernet 2 used for case lineup peer communication and BACnet IP
NA	USB	Universal Serial Bus female connector. Emerson use only.
NA	Auxiliary Port	Connection to CC200 expansion module if present
NA	Expansion Port	Connection to CC200 expansion module if present
31-32	DI1-C	Potential free digital Input 1 and common. Software selectable function.
33-35	DI2-C	Potential free digital Input 2 and common. Software selectable function.
35-37	DI3-C	Potential free digital Input 3 and common. Software selectable function.
37-39	DI4-C	Potential free digital Input 4 and common. Software selectable function.
39-40	AO1	Analog output 1 connection, software selectable function
31-42	AO2	Analog output 2 connection, software selectable function
43-45	Pressure 0V, Sig, +5V	Pressure transducer connection, .5-4.5VDC software selectable EU range
46-47	DAT	Discharge air temperature sensor connection, non-polarity sensitive
48-49	Term	Defrost termination temperature sensor connection, non-polarity sensitive
50-51	RAT	Return air temperature sensor connection, non-polarity sensitive
52-53	Coil Out	Coil outlet temperature sensor connection, non-polarity sensitive
54-55	Def CT Amps	Defrost heater amperage current transducer, optional
56-57	AI 1	Auxiliary analog input 1 connection, software selectable function
58-59	AI 2	Auxiliary analog input 2 connection, software selectable function
60-61	Aux Pwr	Auxiliary power supply for transducers requiring 12VDC external power
NA	PWR ON	Power on LED, indicates supply power is present to the main controller
71	Earth	Earth ground connection for the main controller
72-73	POWER SUPPLY 24VDC	Supply power connection for 24VDC, polarity sensitive + to + and – to – must be observed

74-75	STEPPER BATTERY	<i>Future option for battery backup to drive stepper valves to safe position during power failure</i>
NA	Valve Open Close	LED for open and close indication of attached stepper valve
76-77	STEPPER VALVE W2	Winding 2 connection for stepper valve motor wiring harness
78-79	STEPPER VALVE W1	Winding 1 connection for stepper valve motor wiring harness
80	STEPPER +12V	12V for unipolar stepper motors













Table 2 Expansion Module Hardware Platform Parts

LEGEND		
Terminal	Label	Purpose
4-6	TRIAC	Connection of PWM expansion valve
NA	ADDRESS	Dipswitch ban for setting communication bus address
NA	PWR ON	Power on LED, indicates supply power is present to the main controller
NA	Valve Open – Close	LED for open and close indication of attached stepper valve
NA	Expansion Port	Connection to CC200 Main Controller or an additional Expansion Module
10-11	DI1-C	Potential free Digital Input 1 and common. Software selectable function.
12-14	Pressure 0V, Sig, +5V	Pressure transducer connection. .5-4.5VDC software selectable EU range
15	+12V	Auxiliary power supply for transducers requiring 12VDC external power
16-17	DAT	Discharge air temperature sensor connection, non-polarity sensitive
18-19	Term	Defrost termination temperature sensor connection, non-polarity sensitive
20-21	RAT	Return air temperature sensor connection, non-polarity sensitive
22-23	Coil Out	Coil outlet temperature sensor connection, non-polarity sensitive
33-34	STEPPER VALVE W2	Winding 2 connection for stepper valve motor wiring harness
35-36	STEPPER VALVE W1	Winding 1 connection for stepper valve motor wiring harness
37	STEPPER +12V	12V for unipolar stepper motors

Table 3 Case Display Icons and Description

Icon	Item	Description
	Navigate Back	Navigate back, tap once to navigate back to previous menu
	Cooling Active/Inactive	Refrigeration active icon, status if the system is actively cooling
	Fan Active/Inactive	Evaporator fan icon, status of evaporator fan motor command
	Quick view of Setpoint	SET provides quick access to view the setpoint, tap once to view the current active air setpoint



	Start/Stop Manual Defrost	Manual defrost action icon, long press to start or stop a manual defrost
	Service Shutdown	Service shutdown action icon, long press to start or stop a service shutdown
	Activate Bluetooth	Bluetooth activation icon, long press to switch on/off Bluetooth
	Alarm Active	Alarm indicator icon, illuminates when at least one alarm is present
	Units	Celsius temperature engineering unit label
	Enter Menu/Save Edit	PRG button to enter menus and save parameter edits
	Defrost Active/Inactive	Defrost active icon, illuminates when defrost cycle is active
	Lights Active/Inactive	Lights active icon, illuminates when case lighting is on
	Bluetooth Status	Bluetooth connection status, blinks when ready to connect, solid on when connected to mobile device
	Shortcut to Settings	Shortcut to BACnet addressing menu, long press to enter BACnet settings menu
	Reboot CC200	Reboot CC200 action icon, long press to reboot CC200 controller
	More Available	More pages indicator, present when more content is available by swiping
	Units	Fahrenheit temperature engineering unit label

The contents of this publication are presented for informational purposes only and are not to be construed as warranties or guarantees, express or implied, regarding the products or services described herein or their use or applicability. Emerson and/or its affiliates (collectively "Emerson"), as applicable, reserve the right to modify the design or specifications of such products at any time without notice. Emerson does not assume responsibility for the selection, use or maintenance of any product. Responsibility for proper selection, use and maintenance of any Emerson product remains solely with the purchaser or end user.