

Application Engineering

EVM and EVM-Pro Series Variable Frequency Drives

BULLETIN NO: AE8-1456 R1

Contents

Safety

Safety Icon Explanation	3
Drive Safety Information.....	4
Other Important Safety Information.....	5
Additional Information.....	6
Common Abbreviations	6

INTRODUCTION

Product Description	7
Product Features.....	7
Theory of Drive Operation	8
Standards and Certifications	8
Nomenclature	8
Product Offering	9

TECHNICAL DATA AND SPECIFICATIONS

Product Specifications	9
Drive Dimensions.....	12
Control Board Layout	12
Main Keypad and Display Overview	12
Main Keypad Display	14
Main Keypad Menu Navigation	14
Remote Keypad Overview	15
Remote Keypad LED Lights	18
Remote Keypad Menu Navigation	19
Standard Application	20
I/O Controls.....	20
Wiring Diagram and I/O Connections.....	20
Fan Control Application	21
Pump Control Application	22
Multi-Purpose Application.....	22
Safe Torque Off (STO) Function.....	23
Safety function	23
Safe state	23
System response time	23
STO input signal requirement	23
Requirement for installation, commission, maintenance.....	25

RECEIVING AND INSPECTION

Unpacking the Drive	27
---------------------------	----

GENERAL INSTALLATION

Drive Handling	28
Drive System.....	28
Electrical Installation	31
Wiring Selection	31

Power and Motor leads	31
Lines and Motor Cable Installation	31
Input protection.....	31
Cable Routing.....	31
Wiring the VFD.....	31
Ground wiring	31
Checking the cable and motor insulation	32
Input Connections and Configuration	33
Input Voltage and Frequency.....	33
Input Voltage Balance.....	34
Total Harmonic Distortion (THD)	34
Reactive Power Compensation Devices	35
EMC Installation	35
EMC measures in the control panel.....	35
Earthing.....	37
Screen Earth Kit.....	37
Installation in corner-grounded network and IT system	37
NEMA 1 Kits	38
Mounting and Space Requirements	39
Standard Mounting Instructions	39
DRIVE SELECTION	
General Drive Sizing	41
Compressors	41
Pumps and Fans.....	43
STARTUP AND COMMISSIONING	
Startup Wizard Page	44
Startup Wizard	44
COMMUNICATION	
Communication Features	47
Optional Communication Cards.....	48
Modbus RTU Onboard Communication.....	48
Modbus RTU Specifications.....	49
Communication Board Connections	49
Connection Options.....	49
System Integration	50
MAINTENANCE AND INSPECTION	
STORAGE	
Charging the internal DC link capacitors.....	51
TROUBLESHOOTING	

FIGURES AND TABLES

Figure 1 Nomenclature **8**
 Figure 2 EVM Control Board Layout..... **12**
 Figure 3 EVM-Pro Control Board Layout **12**
 Figure 4 EVM-Pro Main Keypad and Display Layout **13**
 Figure 5 EVM-Pro LCD Display **14**
 Figure 6 Main Keypad Menu Navigation..... **15**
 Figure 7 Remote Keypad and Display Layout **16**
 Figure 8 Remote Keypad Connection **18**
 Figure 9 Remote Keypad Menu Navigation **19**
 Figure 10 Wiring Diagram and I/O Connections..... **21**
 Figure 11 Functional Block Diagram **24**
 Figure 12 STO Wiring Diagram..... **25**
 Figure 13 Unpacking the drive **27**
 Figure 14 Drive System **29**
 Figure 15 EVM Installation Overview **30**
 Figure 16 Drive Grounding..... **32**
 Figure 17 AC power networks types **33**
 Figure 18 EMC Compliant Setup **36**
 Figure 19 Location of the EMC/MOV screw in FR1..... **37**
 Figure 20 Location of the EMC/MOV screws in FR2-4. **38**
 Figure 21 NEMA 1 Kits **38**
 Figure 22 Mounting Orientation **39**
 Figure 23 Acceleration and Deceleration time **47**

Figure 24 Typical Arrangement with Host Computer (Master)..... **49**
 Figure 25 EVM Modbus Terminals **49**
 Figure 26 EVM-Pro Modbus Terminals..... **50**
 Table 1 EVM and EVM-Pro **7**
 Table 2 EVM Product Features..... **7**
 Table 3 Standards and Certifications **8**
 Table 4 EVM Drive Offering **9**
 Table 5 EVM Drive Specifications **9**
 Table 6 Main Keypad Buttons..... **13**
 Table 7 LCD Display Lines **14**
 Table 8 Remote Keypad Buttons **16**
 Table 9 LED Light Categories **18**
 Table 10 Basic Application Functions **20**
 Table 11 Safety Related Parameters. **23**
 Table 12 Power Supply Input/Output **25**
 Table 13 Drive System Components **28**
 Table 14 Space and Cooling Air Requirements **40**
 Table 15 Approved Frequency for Copeland™ Fixed Speed Compressors **42**
 Table 16 Communication Features **47**
 Table 17 Communication Board Connections..... **49**
 Table 18 Maintenance Interval..... **50**

APPENDIX

Appendix A	List of EVM models
Appendix B	Drive Dimensions
Appendix C	Application Parameters
Appendix D	Mounting and NEMA 1 kit Installation
Appendix E	Cable and Fuse Sizing Guidelines
Appendix F	Quick Start Guide
Appendix G	Variable Speed Key Parameters
Appendix H	Communication Card Installation
Appendix I	Troubleshooting and Fault Codes
Appendix J	Modbus RTU Commissioning
Appendix K	Temperature Derating
Appendix L	Advanced Features
Appendix M	Accessories



Copeland Variable Frequency Drives, EVM Series Unboxing and Installation Guide

SAFETY INSTRUCTIONS

Copeland™ products are manufactured according to the latest U.S. and European Safety Standards. Particular emphasis has been placed on the user's safety. Safety icons are explained below. **You are strongly advised to follow these safety instructions.**

Safety Icon Explanation



DANGER indicates a hazardous situation which, if not avoided, will result in death or serious injury.



WARNING indicates a hazardous situation which, if not avoided, could result in death or serious injury.



CAUTION, used with the safety alert symbol, indicates a hazardous situation which, if not avoided, could result in minor or moderate injury.



NOTICE is used to address practices not related to personal injury.



CAUTION, without the safety alert symbol, is used to address practices not related to personal injury.

Drive Safety Information

BEFORE COMMENCING THE INSTALLATION

- Disconnect the power supply of the device
- Ensure that devices cannot be accidentally restarted
- Verify isolation from the supply
- Cover or enclose any adjacent live components
- Only suitably qualified personnel in accordance with **EN 50110-1/-2 (VDE 0105 Part 100)** may work on this device/system
- Before installation and before touching the device ensure that you are free of electrostatic charge
- The functional earth (FE, PES) must be connected to the protective earth (PE) or the potential equalization. The system installer is responsible for implementing this connection
- Connecting cables and signal lines should be installed so that inductive or capacitive interference does not impair the automation functions
- Install automation devices and related operating elements in such a way that they are well protected against unintentional operation
- Suitable safety hardware and software measures should be implemented for the I/O interface so that an open circuit on the signal side does not result in undefined states in the automation devices
- Ensure a reliable electrical isolation of the extra-low voltage of the 24 V supply. Only use power supply units complying with **IEC 60364-4-41 (VDE 0100 Part 410)** or **HD384.4.41 S2**
- Deviations of the input voltage from the rated value must not exceed the tolerance limits given in the specifications, otherwise this may cause malfunction and dangerous operation
- Emergency stop devices complying with **IEC/EN 60204-1** must be effective in all operating modes of the automation devices. Unlatching the emergency-stop devices must not cause a restart
- Devices that are designed for mounting in housings or control cabinets must only be operated and controlled after they have been installed and with the housing closed. Desktop or portable units must only be operated and controlled in enclosed housings
- Measures should be taken to ensure the proper restart of programs interrupted after a voltage dip or failure. This should not cause dangerous operating states even for a short time. If Necessary, emergency stop devices should be implemented
- Wherever faults in the automation system may cause injury or material damage, external measures must be implemented to ensure a safe operating state in the event of a fault or malfunction (for example, by means of separate limit switches, mechanical interlocks, and so on)
- Depending on their degree of protection, adjustable frequency drives may contain live bright metal parts, moving or rotating components, or hot surfaces during and immediately after operation
- Removal of the required covers, improper installation, or incorrect operation of motor or variable frequency drive may cause the failure of the device and may lead to serious injury or damage
- The applicable national accident prevention and safety regulations apply to all work carried out on live adjustable frequency drives
- The electrical installation must be carried out in accordance with the relevant regulations (for example, regarding cable cross sections, fuses, PE)
- Transport, installation, commissioning, and maintenance work must be carried out only by qualified personnel (IEC 60364, HD 384 and national occupational safety regulations)
- Installations containing adjustable frequency drives must be provided with additional monitoring and protective devices in accordance with the applicable safety regulations. Modifications to the adjustable frequency drives using the operating software are permitted
- All covers and doors must be kept closed during operation
- To reduce hazards for people or equipment, the user must include in the machine design measures that restrict the consequences of a malfunction or failure of the drive (increased motor speed or sudden standstill of motor). These measures include:
 - ✓ Other independent devices for monitoring safety-related variables (speed, travel, end positions, and so on)
 - ✓ Electrical or non-electrical system-wide measures (electrical or mechanical interlocks)
 - ✓ Never touch live parts or cable connections of VFD after it has been disconnected from power supply. Due to the charge in capacitors, these parts may still be live after disconnection. Fit appropriate warning signs.

Other Important Safety Information



- The components of the power unit of EVM Series are live when the AC drive is connected to mains potential. Coming into contact with this voltage is extremely dangerous and may cause death or severe injury.
- Motor control equipment and electronic controllers are connected to hazardous line voltages. When servicing drives and electronic controllers, there may be exposed components with housings or protrusions at or above line potential. Extreme care should be taken to protect against shock.



- At power-up, power brake or fault reset the motor will start immediately if the start signal is active, unless the pulse control for Start/Stop logic has been selected. Furthermore, the I/O functionalistic (including start inputs) may change if parameters, applications or software are changed. Disconnect, therefore, the motor if an unexpected start can cause danger.
- After disconnecting the AC drive from the mains, wait until the indicators on the keypad go out (if no keypad is attached see the indicators on the cover). Wait 5 more minutes before doing any work on the connections of EVM Series Drive. Do not open the cover before starting any electrical work!
- During a ramp stop (see the Application Manual), the motor is still generating voltage to the drive. Therefore, do not touch the components of the AC drive before the motor has completely stopped. Wait until the indicators on the keypad go out (if no keypad is attached see the indicators on the cover). Wait additional 5 minutes before starting any work on the drive.



- The motor starts automatically after automatic fault reset if the auto restart function is activated. See the Application Manual for more detailed information.
- Do not perform any measurements when the AC drive is connected to the mains.
- If the EVM drive is used as a part of a machine, the machine manufacturer is responsible for providing the machine with a supply disconnecting device (EN 60204-1).
- The ground leakage current of EVM Series AC drives exceeds 3.5 mA AC. According to standard EN61800-5-1, a reinforced protective ground connection must be ensured.
- The relay outputs and other I/O-terminals may have a dangerous control voltage present even when EVM drive is disconnected from mains.
- Wear safety glasses whenever working on electronic controllers or rotating machinery.
- Stand on an insulating pad and make it a habit to use only one hand when checking components. Always work with another person in case an emergency occurs.
- Before connecting the AC drive to mains, confirm that the front and cable covers of EVM Series Drive are closed.
- Disconnect power before checking controllers or performing maintenance. Be sure equipment is properly grounded.
- The motor terminals U, V, W and the brake resistor terminals are live when EVM Series is connected to mains, even if the motor is not running.
- The control I/O terminals are isolated from the mains potential. However, the relay outputs and other I/O terminals may have dangerous control voltage present even when EVM is disconnect from power

NOTICE

- Remove external control signal before resetting the fault to prevent unintentional restart of the drive.

NOTICE

- EVM Series drive is meant for fixed installations only.
- Check that the EMC level of the drive corresponds to the requirements of the supply network.
- Do not touch the components on the circuit boards. Static voltage discharge may damage the components.

Additional Information

The EVM drive must always be grounded with a grounding conductor connected to the grounding terminals.(Input and output)

Please follow the grounding practices from the Installation Manual to properly address and protect from any grounding issues.

The ground fault protection inside the drive protects only the drive itself against ground faults in the motor or the motor cable. It is not intended for personal safety. Due to the high capacitive currents present in the drive, fault current protective switches may not function properly.

Do not perform any voltage withstand tests on any part of EVM Series. There is a certain procedure according to which the tests shall be performed. Ignoring this procedure may result in damaged product.

Common Abbreviations

Abbreviation	Definition
VT	Variable torque with low overload rating (110%)
I _L	Low overload Current (110%)
VFD	Variable Frequency Drive

Note: EVM-12DXXX variable torque w/o overload rating (100%)

COPELAND

Cat. No.: EVM-XXXXXX-XXXXXX
 Style No.: 3-XXXX-XXXX Ident ID: XXXXXXXX
 Copeland EVM VFD Factory ID: Plant 11

VT		Input	Output
	U(V~)	200-240 3Ø	0-Vin 3Ø
XX.X HP (XX.XX KW)	F(Hz)	50/60 Hz	0-400 Hz
	I (A)	XX.X	XX.X

IE Class IE2
 90/100 loss X.X%

Details Copeland.com/CopelandVariableFrequencyDrives

Enclosure Rating IP20 / UL Open Type
 IP20 / NEMA 1 / UL Type 1 with NEMA 1 kit installed

User installation manual:2020ECT-36
 Serial No.: ASXXXXXXX









Contains FCC ID: 2ADXE-HY-40R204PC
 Contains IC: 23267-HY40R204PC

Field installed conductors must be copper rated at 75°C
 XXXXXX Assembled in Dominican Republic

INTRODUCTION

Product Description

Variable frequency drives help various processes achieve energy savings and product quality. The Copeland EVM Series VFD is designed for applications where less control functionality is needed with motor capacity range of 0.5 – 29 HP. The EVM drive has been developed specifically for various application. The EVM drive will provide power and control the motor running speed of compressors, fans, or pumps.

The EVM variable frequency drive will be referred to as the “variable frequency drive”, “drive” or “the VFD” through out this bulletin.

Table 1 EVM and EVM-Pro

EVM	<ul style="list-style-type: none"> 4 frame sizes (0.5 – 29hp) 120V or 230V Single Phase Input 230, 480 and 575V Three Phase No keypad/display No STO Modbus onboard communication No communication cards Bluetooth 	EVM-Pro	<ul style="list-style-type: none"> 4 frame sizes (0.5 – 29hp) 120V or 230V Single Phase Input 230, 480 and 575V Three Phase Keypad with display Onboard STO 5 onboard communications 4 communication cards Bluetooth
------------	--	----------------	--

Product Features

Table 2 EVM Product Features

Enclosure / Safety Rating	<ul style="list-style-type: none"> IP20 standard Optional NEMA 1 kit * SIL 2 with onboard STO * Optional EMI filter Brake chopper standard 	Onboard I/O	<ul style="list-style-type: none"> 4 Digital Inputs 1 Analog Input-Selectable 1 Analog Output-Selectable 2 Relay Outputs
Onboard Communications	<ul style="list-style-type: none"> Modbus RTU BACnet MS/TP Ethernet/IP * Modbus TCP * BACnet IP * 	Communication Cards	<ul style="list-style-type: none"> PROFIBUS * CANopen * Dual-port Ethernet adapter *
STO (Safe Torque Off)	<ul style="list-style-type: none"> Reduce the need for contactors 		

*Upgraded features

Theory of Drive Operation

The primary purpose of the variable frequency drive is to convert the 50/60 Hz AC input voltage into a variable frequency, variable voltage output to power the compressor. The drive conditions the AC input voltage through a series of processes to arrive at the desired output. The drive first converts the AC input voltage into a DC voltage. The DC voltage is then pulse-width modulated to replicate a sinusoidal current at the desired frequency and voltage.

Standards and Certifications

Informações Regulatórias ANATEL

Incorpora produto homologado pela ANATEL sob o número 10172-22-14932.

Este equipamento não tem direito à proteção contra interferência prejudicial e não pode causar interferência em sistemas devidamente autorizados.

Para maiores informações, consulte o site da ANATEL www.gov.br/anatel/pt-br [gov.br]

SAFETY	UL 61800-5-1 CSA C22.2 No. 274-17 EN 61800-5-1
ELECTROSTATIC DISCHARGE	Second environment, IEC 61000-4-2, 4 kV CD or 8 kV AD, Criterion B
FAST TRANSIENT BURST	Second environment, IEC 61000-4-4, 2 kV/5 kHz, Criterion B
DIELECTRIC STRENGTH	Primary to secondary: 3600 Vac/5100 Vdc Primary to earth: 2000 Vac/2828 Vdc
APPROVALS	CE, UL and cUL, EAC, RCM (C-Tick), RoHS, TUV, FCC, ANATEL

Table 3 Standards and Certifications

Nomenclature

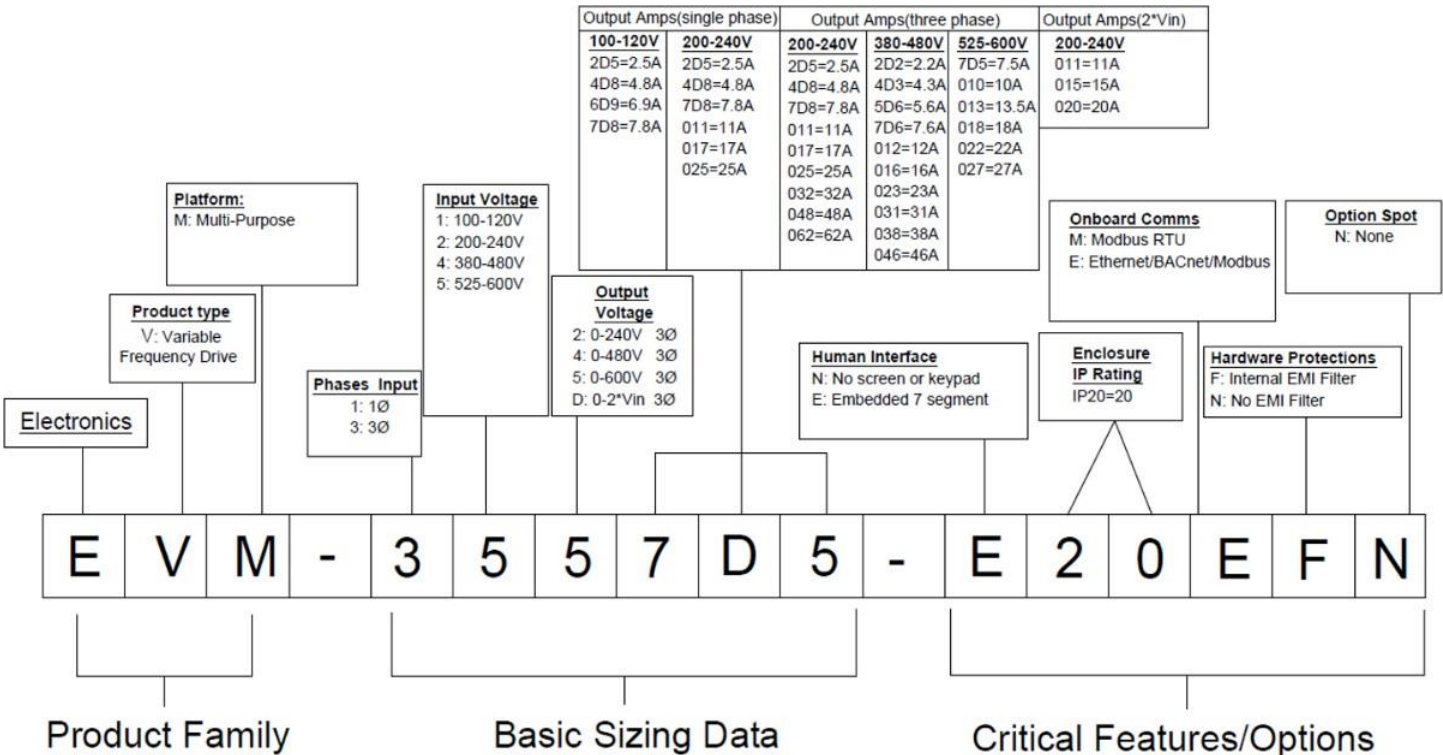

Figure 1 Nomenclature

Product Offering

Basic Version				
Voltage/Phase		Max. Output Current Rating Range (A)	Max. Output Power Rating Range kW (HP)	Internal EMI Filter
Input	Output			
200-240V 3ph		2.5 - 62	0.37 to 15 (0.5 to 20)	Optional
380-480V 3ph		2.2 - 46	0.75 to 22 (1.0 to 29)	Optional
Pro Version				
Voltage/Phase		Max. Output Current Rating Range (A)	Max. Output Power Rating Range kW (HP)	Internal EMI Filter
Input	Output			
100-120V 1ph	200-240V 3ph	2.5 – 7.8	0.37 to 1.5 (0.5 to 2.0)	Optional
200-240V 1ph	200-240V 3ph	2.5 – 25	0.37 to 5.5 (0.5 to 7.3)	Optional
200-240V 3ph		2.5 – 62	0.37 to 15 (0.5 to 20)	Optional
380-480V 3ph		2.2 – 46	0.75 to 22 (1.0 to 29)	Optional
575V 3ph		7.5 – 27	3 to 18.5 (5 to 25)	Optional

Table 4 EVM Drive Offering

Please see **Appendix A** for the complete list of EVM models.

TECHNICAL DATA AND SPECIFICATIONS

Product Specifications

Table 5 EVM Drive Specifications

Section	Description	Specification
Input ratings	Voltage tolerance	Max +10% to -15%
	Input frequency	45 to 65 hz
	Input THD	>120%
	Connection to power	Once per minute or less
	Start delay	4 s
	Short-circuit withstand rating	100 kAIC (Fuses and circuit breakers) 65 kAIC (Type E CMC) 14 kAIC (Miniature breakers) 5 kAIC (All)
	Power ride-thru	100 ms
	Logic control ride-thru	0.5 s Min, 2 s typical
	Total watts loss typical	Typical efficiency 97.5% for three phase
Output ratings	Output voltage	115V single phase, 230V single & three phase, 480V three phase, & 575V three phase
	Continuous output current	IL: ambient temperature max 50 °C, up to 60 °C with derating, overload 1.1 x IL (1 min/10 min)
	Overload current	110% of drive rating for variable torque
	Initial output current	200% (2 sec/20 sec)
	Output frequency	0-400 Hz (standard)

	Frequency resolution	0.01 Hz
Control Characteristics	Control methods	Frequency control, Speed control, PM motor speed control
	Performance V/Hz (volts per Hertz) SVC (sensor-less vector) PM motor	±0.5% of base speed across a 30:1 speed range ±0.5% of base speed across a 60:1 speed range ±0.5% of base speed, up to a 20:1 speed range
Control Characteristics	Switching frequency	1kHz to 16kHz Automatic switching frequency derating in case of overload
	Frequency reference	Analog input: resolution 0.1% (10-bit), accuracy +1% Analog output: resolution 0.1% (10-bit), accuracy +1% Panel reference: resolution 0.01 Hz
	Field weakening point	20 Hz to 400 Hz
	Acceleration time	0.1 s to 3000 s
	Deceleration time	0.1 s to 3000 s
	Braking torque	DC brake: 30% x motor rated torque (Tn) (without brake chopper) Dynamic braking (with optional brake chopper using an external brake resistor): 100% continuous maximum rating
Protections	Overvoltage protection	Yes
	Overvoltage trip limit	115V & 230V drives: 430Vdc, 480V drives: 850Vdc, 575V drives: 1050Vdc
	Undervoltage protection	Yes
	Undervoltage trip limit	115V & 230V drives: 175Vdc, 480V drives: 390Vdc, 575V drives: 560Vdc
	Earth fault protection	Yes
	Input phase supervision	Yes
	Motor phase supervision	Yes
	Overcurrent protection	Yes
	Unit over-temperature protection	Yes
	Motor overload protection	Yes
	Motor stall protection	Yes
	Motor underload protection	Yes
	DC bus overvoltage control	Yes
Short-circuit protection of 24V supply	No	
Surge protection	Yes (differential mode 1 kV; common mode 2 kV)	
Control section	Control voltage	24 Vdc, max 100mA
	Reference voltage	10.3 Vdc max 10mA
	Digital Inputs:	
	Quantity	4 programmable
	Type	Positive or negative logic; 18 to 30 Vdc,
	Maximum switching speed	1 kHz
	Relay output:	
Quantity	2 programmable (1 Form C relay and 1 N/O form A relay) Note: EVM-Pro only. EVM has only 1 form A relay on board	

	Specification	Switching capacity: Resistive rating:3.0A @ 30Vdc, & 125V, 240V AC Inductive rating:0.5 A @ 30Vdc, & 125V, 240V AC
--	---------------	--

Control section	Analog Input:	
	Quantity	1 dipswitch selectable 0-10Vdc or 4 to 20mA
	Resolution	10-bit
	0-10V DC Analog	100k ohm input impedance
	4-20mA analog	250-ohm input impedance
	External pot	1-10kohm, 2 watts minimum
	Analog Output:	
	Quantity	1 dipswitch selectable 0-10Vdc or 4 to 20mA
	Specification	
	Resolution	10-bit
	0-10V DC Analog	10mA max
4-20mA analog	RL max 500 ohm	
Communications	Ethernet I/P	Onboard (EVM-Pro only)
	Modbus TCP	Onboard (EVM-Pro only)
	BACnet I/P	Onboard (EVM-Pro only)
	Modbus RTU	Onboard
	BACnet MSTP	Onboard (EVM-Pro only)
	Dualport ethernet I/P	Optional (EVM-Pro only)
	Profibus	Optional (EVM-Pro only)
	CANOPEN	Optional (EVM-Pro only)
Environmental	Ambient operating temperature	-30 °C (no frost & Cold weather Mode activated) to +50 °C, up to +60 °C with derating
	Storage temperature	-40 °C to +70 °C
	Relative humidity	0-95% RH, noncondensing, non-corrosive
	Air quality: • Chemical vapors • Mechanical particles	Tested according to IEC 60068-2-60 Test Key: Flowing mixed gas corrosion test, method 1 (H2S [hydrogen sulfide] and SO2 [sulfur dioxide]) Designed according to IEC 60721-3-3, unit in operation, class 3C2
	Vibration: • EN 61800-5-1 • EN 60068-2-6	Vibration test at operating status Displacement amplitude: 0.075 mm (peak) at 10 Hz to 57 Hz Maximum acceleration amplitude: 1g at 57 Hz to 150 Hz
	Shock: • EN 60068-2-27	Shock test at operating status Peak acceleration: 15 g Duration: 11ms
	Transportation: • ISTA 1 A	Transported as a single device in a separate package, Vibration test and drop test per ISTA 1A
	Overvoltage	Overvoltage Category III
	Pollution degree	Pollution Degree 2
	Enclosure Class	IP20 standard NEMA 1 / UL Type 1 with accessory kit
	EMC	EN 61800-3:2004/A1:2012, second environment
	Altitude	100% load capacity (no derating) up to 3280 ft (1000 m) 1% derating for each 328 ft (100 m) above 3280ft, up to 6562 ft (2000 m) (UL listing). Up to 13123 ft (4000 m) (without UL listing) If the installation site is higher than 6562 ft (2000m) above sea level contact Copeland rep
	MTBF	300,000 Hours

Drive Dimensions

Please see **Appendix B** for the detailed dimensions for each frame size.

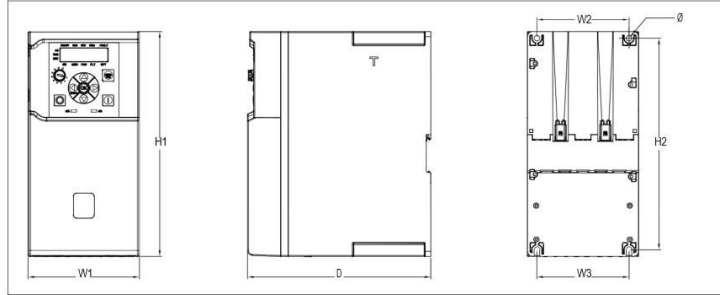

Approximate dimensions in inches

Frame size	D	H1	H2	W1	W2	W3	Ø	Weight lb
FR1	7.09	5.98	5.51	2.83	2.26	2.26	0.20	2.6
FR2	7.09	8.66	8.15	4.29	3.56	3.56	0.22	5.7
FR3	7.09	10.24	9.72	5.12	4.57	4.57	0.22	8.2
FR4	7.68	11.81	11.06	7.24	6.3	6.3	0.24	13.9

Control Board Layout

The EVM drive control board layout is shown on **Figure 2** while the EVM-Pro is shown on **Figure 3**.

Main Keypad and Display Overview

The keypad is the interface between the drive and the user. It features an LCD display, speed potentiometer, and navigation buttons. With the control keypad, it is possible to control the speed of a motor, to supervise the state of the equipment, and to set the drives parameters See **Figure 4** below.

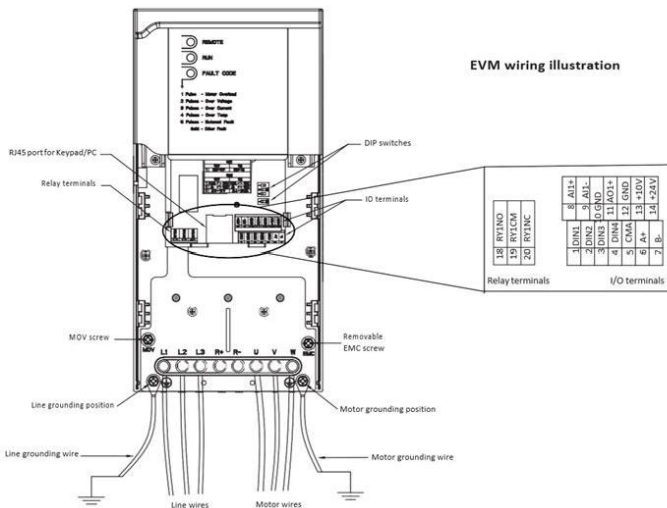

Figure 2 EVM Control Board Layout

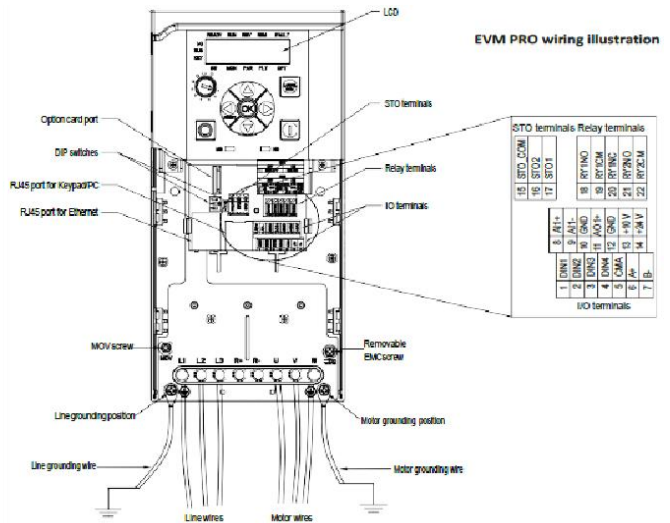

Figure 3 EVM-Pro Control Board Layout

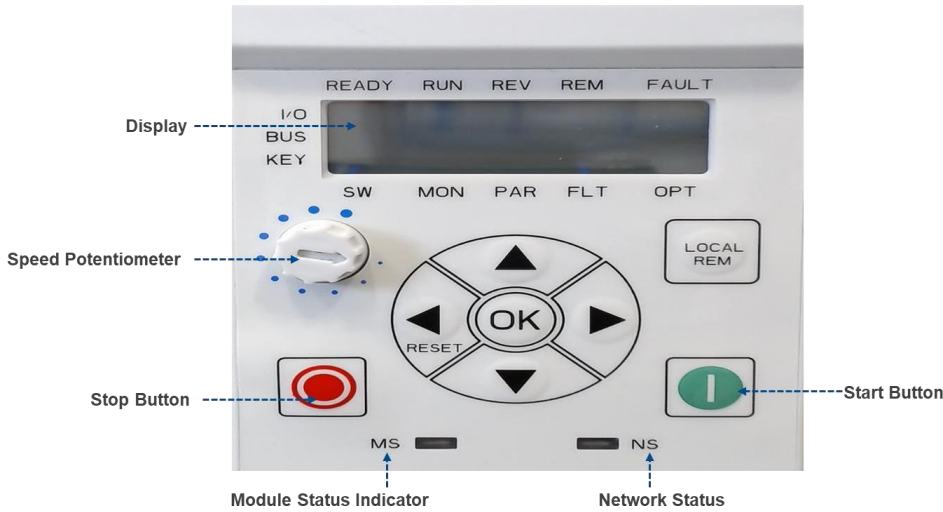

Figure 4 EVM-Pro Main Keypad and Display Layout

Table 6 Main Keypad Buttons

ICON	BUTTON	DESCRIPTION
	LOCAL/REMOTE	Switches between LOCAL and REMOTE control for start and speed reference.
	START	This button operates as motor start button for normal operation when "Keypad" is selected as the active control source.
	STOP	This button operates as a stop button during normal operation when the "Keypad" is selected as the control source.
	Left/Back/Reset	Movement to left when editing a parameter. This button has three integrated functions. The button operates as backward button during normal mode. In edit mode, it is used as cancel operate. It is also used to reset faults when faults occur. Resets the active faults (all the active faults shall be reset by pressing this button more than 2s in any page) Holding the stop and back/reset button for 5 seconds will return drive to factory default. Pressing Back/Reset button at the Main menu will take you to back to the default page.
	UP DOWN	Moving up or down a menu list to select the desired item. Editing a parameter. Increasing/decreasing the reference value of the selected parameter. In parameter page when in read mode, this button is used to move between parameters
	RIGHT	Navigation button, Movement to right when editing a parameter.
	OK	If pressed for more than 5 s in any page this it will clear the fault history. Used to save during the parameter editing mode. Used to confirm the start-up list at the end of the start-Up Wizard. Used to confirm the comparison item in parameters comparison mode.

Main Keypad Display

The main keypad LCD display shown on Figure 5 indicates the status of the motor and the drive and any faults in motor or drive functions. On the display, information about the current location in the menu structure and the item are displayed.

Figure 5 EVM-Pro LCD Display

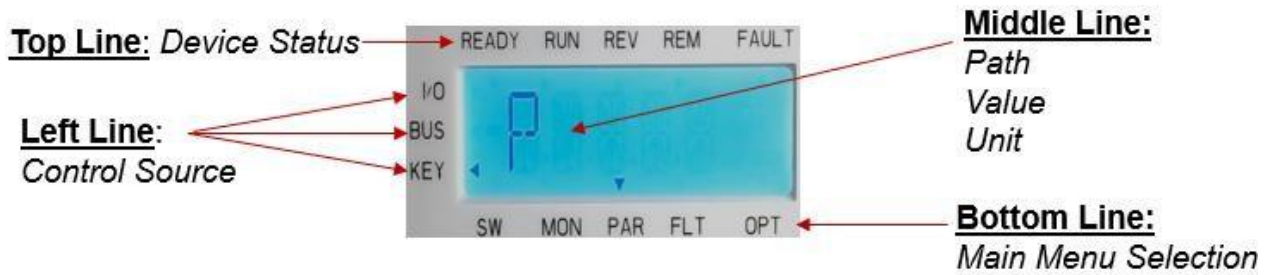
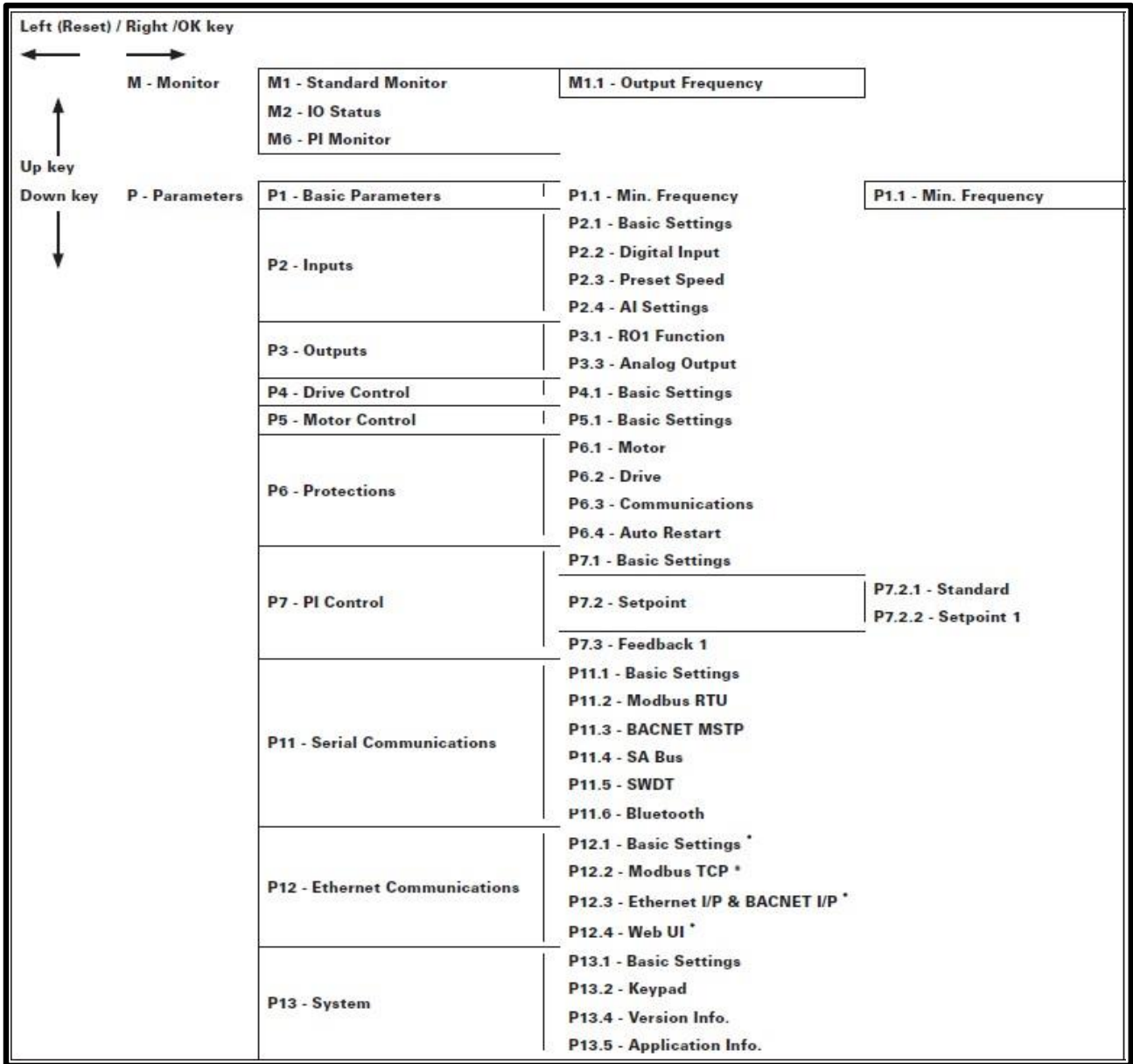

Table 7 LCD Display Lines

Type	Description
Top Line	The top line is state line and indicates whether the device state is: <ul style="list-style-type: none"> • Ready/NRD; • RUN/STP; • REV/FWD; • Remote/Local; or • Fault (lit)/Warning (flashing).
Left Line	The left line indicates the control source: <ul style="list-style-type: none"> • IO; • BUS; or • KEY.
Middle Line	The middle line parameters are: <ul style="list-style-type: none"> • Path; • Value; or • Unit.
Bottom Line	The bottom line is the menu line. It indicates which parameter menu is selected. The choices are: <ul style="list-style-type: none"> • SW: Start-up wizard; • MON: Monitor; • PAR: Parameter; • FLT: Fault; or • OPT: Option cards.

Figure 6: Main Keypad Menu Navigation



*EVM-Pro Only



Remote Keypad Overview

The remote keypad is another interface between the drive and the user. It features an LCD display, 3 LED lights and 11 buttons. With the control keypad, it is possible to control the speed of a motor, to supervise the state of the equipment, and to set the drive parameters.

Figure 7 Remote Keypad and Display Layout



Table 8 Remote Keypad Buttons

ICON	BUTTON	DESCRIPTION
	<p>Softkey 1 Softkey 2</p>	<p>Soft keys 1 and 2 have no functionality with the EVM device.</p>
	<p>Back / Reset</p>	<p>This button has three integrated functions. The button operates as backward button during normal mode. In edit mode, it is used as cancel operate. It is also used to reset faults when faults occur.</p> <ul style="list-style-type: none"> • Backs up one step. • Cancels Modify in edit mode. • Resets the active faults (all the active faults shall be reset by pressing this button more than 2 seconds in any page). • Hold Stop and Back Reset for 5 seconds to return drive to factory default • At Main Menu page by hitting Back/Reset takes to Default Page.
	<p>Local/Remote</p>	<p>Switches between Local and Remote control for start and speed reference.</p>



	<p style="text-align: center;">OK</p>	<ul style="list-style-type: none"> • Will clear all the fault history if pressed for more than 5 seconds (including 5 seconds) in any page. • This button is used in the parameter edit mode to save the parameter setting. • To confirm the start-up list at the end of the Start-Up Wizard. • To confirm the comparison item in parameters comparison mode. The following is the same with Right key: <ul style="list-style-type: none"> • Enter parameter whole edit mode when this parameter can be written. • Enter parameter group mode. • Enter parameter mode from group mode.
	<p style="text-align: center;">UP DOWN</p>	<ul style="list-style-type: none"> • Move either up or down a menu list to select the desired menu item. • Editing a parameter bit by bit, while the active digit is scrolled. • Increase/decrease the reference value of the selected parameter. • In parameter comparison mode, scroll through the parameters of which current value is different from comparison parameter value. • In parameter page when in read mode, move to the previous or next brother parameter of this parameter.
	<p style="text-align: center;">LEFT</p>	<ul style="list-style-type: none"> • Navigation button, movement to left when editing a parameter digit by digit. • Backs up one step.
	<p style="text-align: center;">RIGHT</p>	<ul style="list-style-type: none"> • Enter parameter group mode. • Enter parameter mode from group mode. • Enter parameter whole edit mode when this parameter can be written. • Enter parameter bit by bit edit mode from whole edit mode. <p>Navigation button, movement to right when editing a parameter bit by bit.</p>
	<p style="text-align: center;">STOP</p>	<p>This button operates as motor stop button for normal operation when the “Keypad” is selected as the control source and keypad stop button is active, or stop button is always enabled regardless of control source.</p> <ul style="list-style-type: none"> • Motor stop from the keypad.
	<p style="text-align: center;">START</p>	<p>This button operates as motor start button for normal operation when the “Keypad” is selected as the active control source. When Keypad is the reference place after hitting the start button, it will jump directly to the Keypad Ref Screen.</p>



Figure 8 Remote Keypad Connection

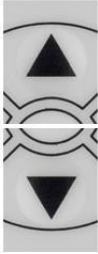
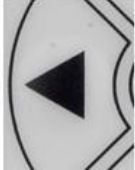

Remote Keypad LED Lights

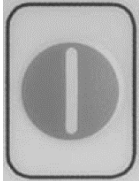
There are different categories of flashing codes that the EVM Drive can annunciate on the remote keypad display – RUN, FAULT and LOCAL/REMOTE. Description of each LED are shown on Table 9.

Table 9 LED Light Categories

<p>RUN</p> 	<ul style="list-style-type: none"> • Solid – Indicates that the VFD is running and controlling the load in the drive • Flashing – A stop command has been given but the drive is still ramping down
<p>FAULT</p> 	<ul style="list-style-type: none"> • Turn ON when there is one or more active drive fault(s)
<p>LOCAL/ REMOTE</p> 	<ul style="list-style-type: none"> • Local: if the local control place is selected, the light will be OFF • Remote: if the remote-control place is selected, the light will be ON

Remote Keypad Menu Navigation

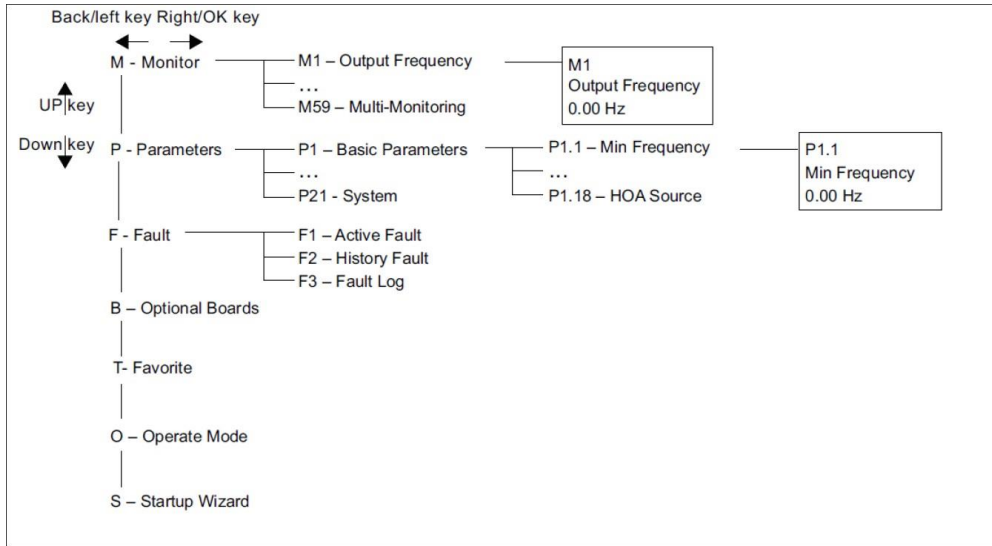

Figure 9 Remote Keypad Menu Navigation

Standard Application

P13.1.2 (Application)

The standard application is default and performs all basic functions of a drive. It allows local and remote control, different speed command sources such as analog input and PID. The standard application allows for basic configuration of fault responses. The standard application supports basic tuning of 3-phase AC induction motors. The standard application allows programming of digital input 3 and 4 and relay outputs 1 and 2.

Table 10 Basic Application Functions

• Selectable digital input function	• Output frequency 1 limit supervision
• Selectable digital output function	• Output frequency 2 limit supervision
• Output signal filter, scaling, inversion, offset, and range	• Torque limit supervision
• Selectable analog output function	• Reference frequency limit supervision
• PID control	• Power limit supervision
• Start source (local/remote control function)	• Analog input limit supervision
• Reference source	• Auto restart
• Flying start	• Programmable switching frequency
• Volts per Hertz control	• Multi-preset speeds
• Drive temperature limit supervision	• Emergency stop
• DC brake	• Fan control
	• Dynamic brake

See **Appendix C** for the complete list of parameter descriptions

I/O Controls

“Function to terminal” (FTT) programming

The design behind programming of the digital inputs and outputs of the EVM uses “function to terminal” programming. It is composed of a terminal, be it a relay output or a digital output, that is assigned a parameter. Within that parameter, it has different functions that can be set.

Wiring Diagram and I/O Connections

- Run 240 Vac and 24 Vdc control wiring in separate conduit
- Communication wire to be twisted & shielded. Fasten the drain wire (ground) to drives ground under the cover.



Figure 10 Wiring Diagram and I/O Connections

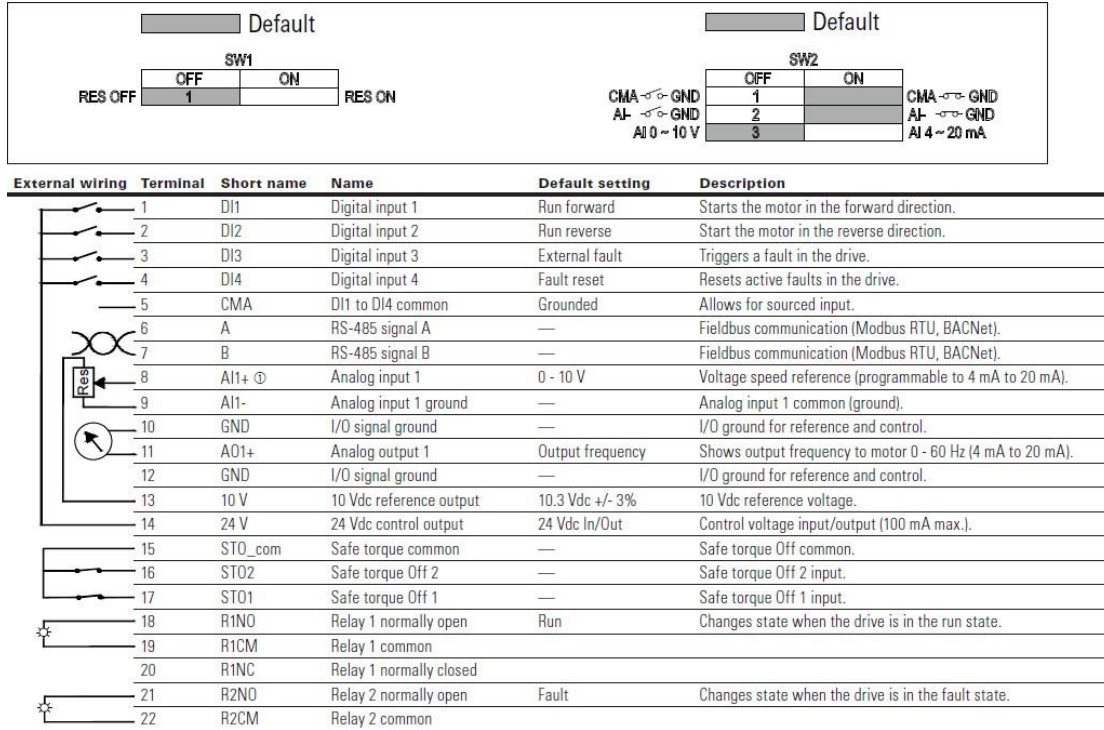

NOTE The above wiring demonstrates a SINK configuration. It is important that CMA and CMB are wired to ground. If a SOURCE configuration is desired, wire 24 V to CMA and CMB and close the inputs to ground. When using the +10 V for AI1, it is important to wire AI1—to ground (as shown by dashed line). If using +10 V for AI1, terminals 9 and 10 need to be jumpered together.

AI1+ and AI2+ Support 10K potentiometer.

Fan Control Application

P13.1.2 (Application)

The fan application builds on the features included in standard. In addition to all the features in the standard application, the fan application provides features specific for HVAC applications and fan related protective features.

Fan application includes functions:

- Damper control;
- Fire mode;
- Smoke purge; and
- Broken belt protection.

See **Appendix C** for the complete list of parameter descriptions.

Pump Control Application

P13.1.2 (Application)

The pump application builds on the features included in standard. In addition to all of the features in the standard application, the pump application provides features specific for pumping applications and pump related protective features.

Pump application includes functions:

- Pump derag mode;
- Valve control;
- Backspin control;
- Minimum run time;
- Separate minimum frequency ramp time;
- Multi-pump control;
- Pipe fill mode;
- Loss of prime detection; and
- Broken pipe detection.

See **Appendix C** for the complete list of parameter descriptions.

Multi-Purpose Application

P13.1.2 (Application)

The multi-purpose application is designed for a large set of applications with the ability to have advanced motor control systems. It takes the same functions provided in the standard and fan applications and adds in some additional control techniques. The application is designed with two control places that use eight digital inputs, two analog inputs, three relay outputs, one digital output, and two analog outputs that are programmable. Motor control-wise, it provides the ability to do frequency and speed control and adds open loop speed control as well as torque control. For tuning the V/Hz curve, it has the ability to go out and ID the motor characteristic and enters those specific measurements into its parameters for better control. Drive/motor protections are programmable for desired actions depending on the application. Below is a list of additional features available in addition to the standard and fan application features that are available in the multi-purpose application.

- BPM control
- Motor potentiometer reference control;
- External brake control;
- Droop function with multiple loads;
- Motor identification;
- Motor control modes;

See **Appendix C** for the complete list of parameter descriptions.

Safe Torque Off (STO) Function

Safe Torque Off (STO) is a function that disables the variable frequency drive (VFD) by having no current or voltage going to the motor. The STO function can be used for stopping the drive during emergency situations. When the drive is stopped by using the STO function, the drive will immediately trip and will cause the motor to coast to stop. The STO disables the output IGBT devices and it is an integral part of the VFD hardware design.

The STO (Safe Torque Off) function of EVM series AC drive is implemented only by hardware and no software is involved to perform the STO function.

The STO function is available for operator to turn off the motor torque. It is intended to be used in the safety related applications up to SIL 2 / SIL CL 2 acc. to IEC 61800-5-2, IEC 61508 and IEC 62061, and up to Cat. 3 / PL d acc. to ISO 13849-1

Safety function

The power that can cause rotation (or motion in the case of a linear motor) shall be switched off from the motor when demanded.

Safe state

The safe state is when the power supply of the motor is switched off.

System response time

The time from when the operator presses the emergency stop button to when the motor power supply switch is turned off is ≤ 1 ms.

STO input signal requirement

The two STO inputs can't be exactly synchronized, STO fault will not be triggered if the two STO inputs become consistent within 200 ms.

Table 11 Safety Related Parameters

OPERATION MODE		FR 1-4
Operation mode		High demand
Safety integrity level		SIL 2 / SIL CL 2
Systematic capability		SC 2
Safety architecture		1oo1 and 1oo2 mixed
Category		3
Performance level		d
System type		B
HFT	1001 part	0
	1002 part	1
SFF of each element	1001 part	> 99%
	1002 part	> 60%
PFH		8.26E-10
PFD		6.76E-05
MTTFd		1041 years (high)
Proof Test Interval (PTI)		20 years
MRT		0 hour
MTTR		0 hour
λ (total failures)		598.30 FIT
λ S (safe failures)		443.06 FIT
λ DD (dangerous detected failures)		107.11 FIT
λ DU (dangerous undetected failures)		54.93 FIT

NOTE: 1 FIT = 10⁻⁹/h.

- All the previously mentioned safety-related parameters are calculated based on the assumptions:
- Failure rate of each component is based on the Siemens SN29500 database
- Component failure rates are constant over the life of the device
- Operating at a maximum ambient temperature of 60 °C with derate
- The equal distribution is used for the failure modes ratio of each component

NOTICE

The parameters mentioned above are calculated by Copeland without considering failure rates of external devices e.g. buttons, power supply, etc.

NOTICE

The STO function shall be triggered at least once a year.

Figure 11 Functional Block Diagram

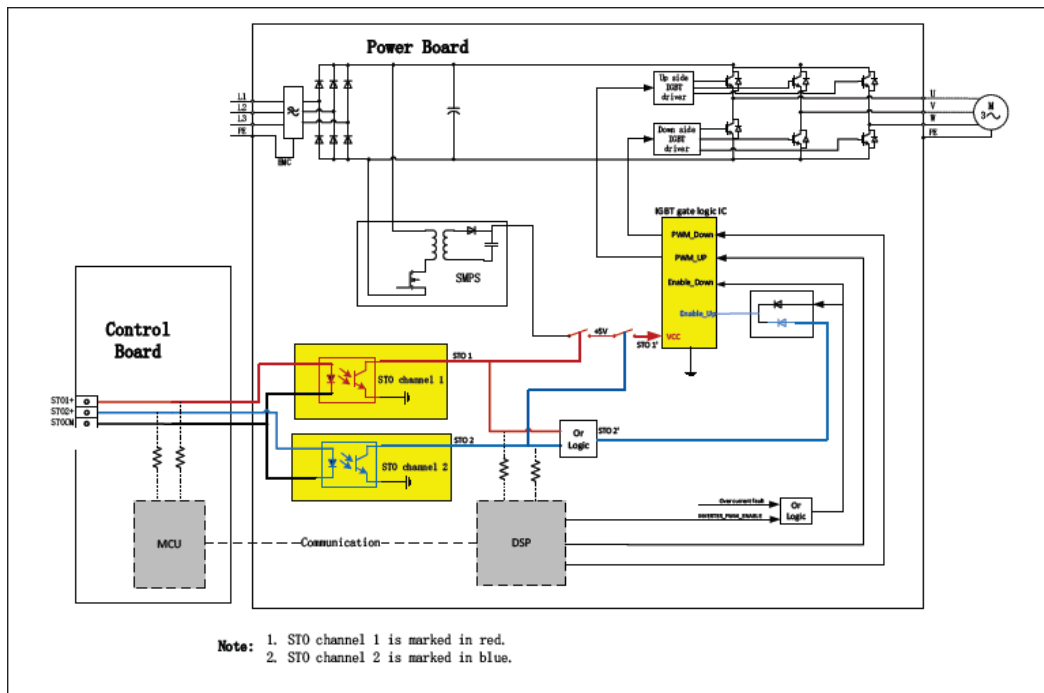

Table 12 Power Supply Input/Output

Power Supply Input Voltage	115V Series	150-450 Vdc
	230V Series	150-450 Vdc
	480V Series	300-880 Vdc
	575V Series	500-1000 Vdc
STO Activation	STO1/STO2	0-1.5 Vdc
STO Deactivation	STO1/STO2	16-28 Vdc

NOTICE

External filter shall be used for non-EMI version drives to keep CE EMC compliance. If an external filter type other than recommended in the manual is used, the CE EMC compliance shall be reconfirmed first. Please contact the your Copeland sales representative or Application Engineer if necessary.

Requirement for installation, commission, maintenance

A three-pin terminal block in control board is used for customer to connect emergency stop switch. After the installation, the STO function shall be verified. Refer to Figure 13 for the detailed wiring method. The emergency stop switch for STO shall be closed state normally. The STO function shall be verified according to following steps:

- Apply main power to EVM drive.
- Run the motor and wait until the motor operating stably.
- Open the switch of STO1 or STO2, both “STO Fault” and “Safety Torque Off” shall be triggered and the motor shut down. Fault codes are FC 23 and FC 66.
- Closed STO1 and STO2 switches.
- Restart motor and wait until the motor operating stably.
- Open the switches of STO1 and STO2 at the same time, only “Safety Torque Off” shall be triggered and the motor shut down. Fault code is FC 66.
- Closed STO1 and STO2 switches. Test finished

NOTICE

STO fault indicates two different fault types. One is the drive internal circuit fault and the other is the case that two STO input signals are not consistent within 200ms.

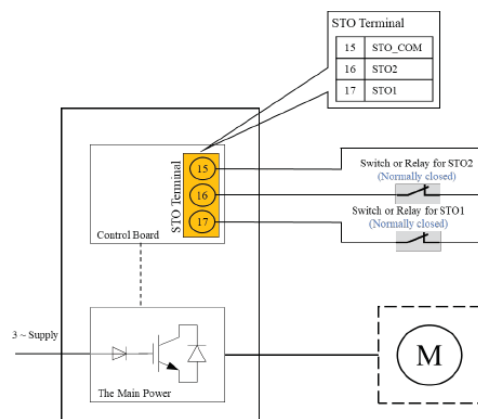

Figure 12 STO Wiring Diagram

The STO terminal block shall be short circuited by jumper if user doesn't need STO function. If the function is used by customer, the STO terminal block shall be connected to emergency stop switch. The STO function needs to be always on, which means the idle-current principle shall be followed by the end user. Fault exclusion measures against short circuit fault between STO1/STO2 and power supply 24VDC must be implemented at application level, according to applicable requirement/standards e.g. ISO 13849-2:2012.

NOTICE

Any circuit connected to the STO terminal block shall be SELV or PELV circuit. STO1 and STO2 shall be both connected with the independent output of the Safety Elements. The STO terminal block is fixed connection and cannot be disconnected without tool. Appendix E defines the control wiring stripping length to ensure no bare conductor exposed after wiring. The safety function STO is not equivalent to the safety function "safe off" of IEC 60204-1:2016, since it does not provide any galvanic insulation. This means that the motor terminals can still have dangerous voltage when in STO state.

RECEIVING AND INSPECTION

The EVM drive has met a stringent series of factory quality requirements before shipment. It is possible that packaging or equipment damage may have occurred during shipment. After receiving your EVM drive, please check for the following:

- Inspect the unit to ensure it was not damaged during shipment.
- Make sure that the part number indicated on the nameplate corresponds with the model number on your order.
- If shipping damage has occurred, please contact and file a claim with the carrier involved immediately.
- If the delivery does not correspond to your order, please contact your sales or Application Engineer representative.
- The magnetic cores and cable ties are only included in EMI version drive.

Unpacking the Drive

Lift the drive out from the carton and remove the packaging as shown on Figure 14.

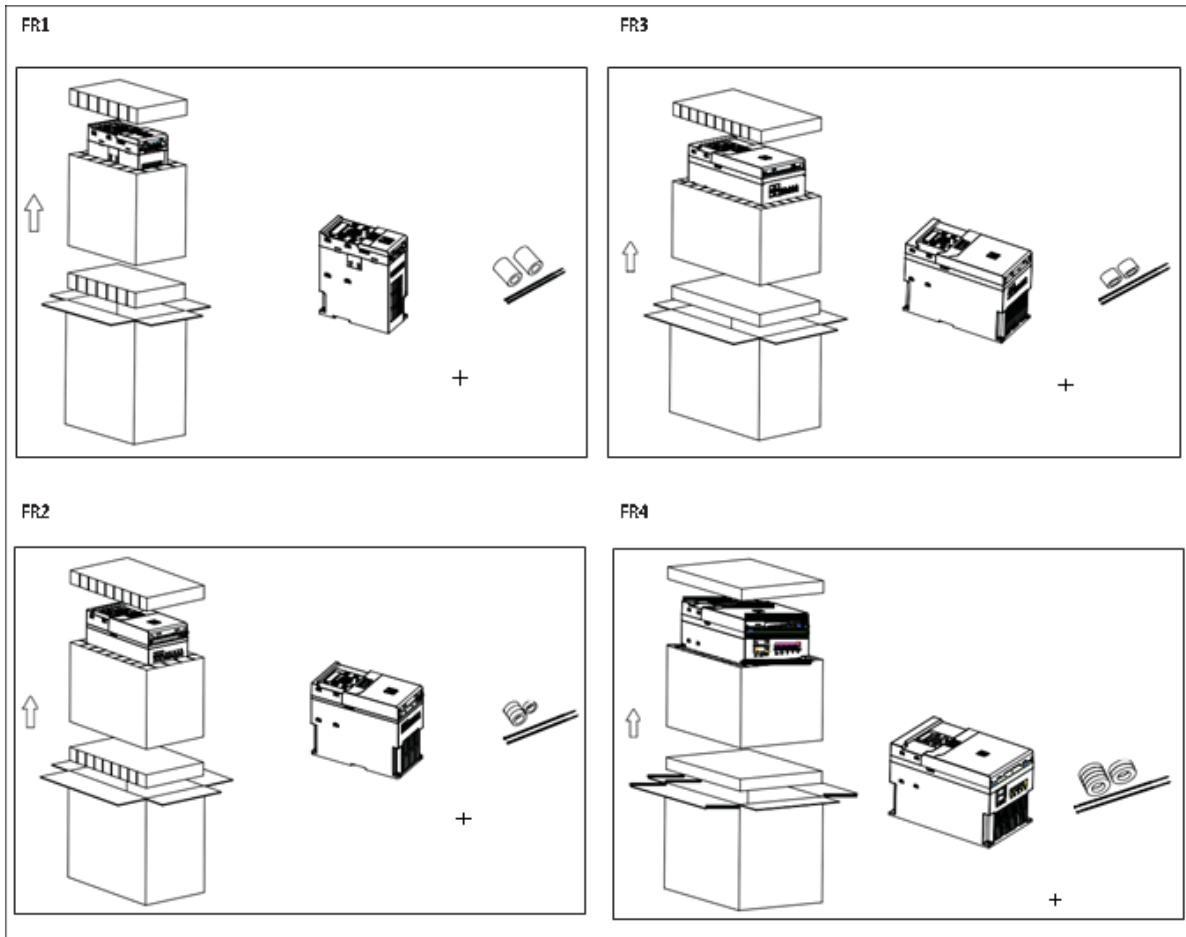

Figure 13 Unpacking the drive

GENERAL INSTALLATION

Drive Handling



- Before opening the drive covers: Disconnect all power to the drive, including external control power that may be present.
- Follow all Arc flash and LOTO procedures before opening cabinet or removing covers.

NOTICE

Correct handling and storage of the drive is essential in preventing mechanical damage.

Never cut across the drive with any sharp materials. Do not stack the drives on each other. Do not drop the drive.

Drive System

The layout of a typical drive system is shown on Figure 15. The description of each of these components are on Table 13.

Table 13 Drive System Components

ITEM	DESCRIPTION
1	Power Grid
2	Breaker, Fuses, Cable Cross Sections
3	Residual-Current Protective Devices
4	Input Contactor
5	Frequency Inverter (EVM Drive)
6	Output Contactor
7	Output Reactor
8	Motor Protection
9	Motor Cables
10	Motor

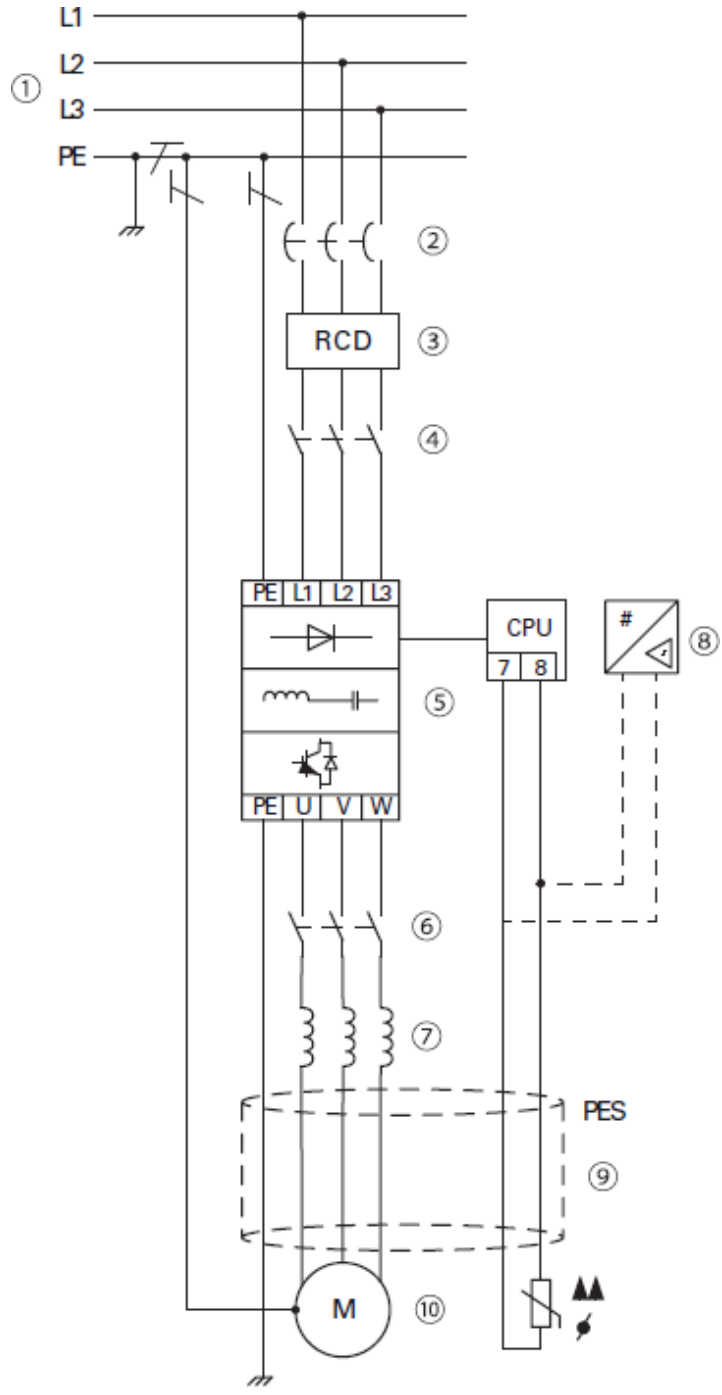

Figure 14 Drive System

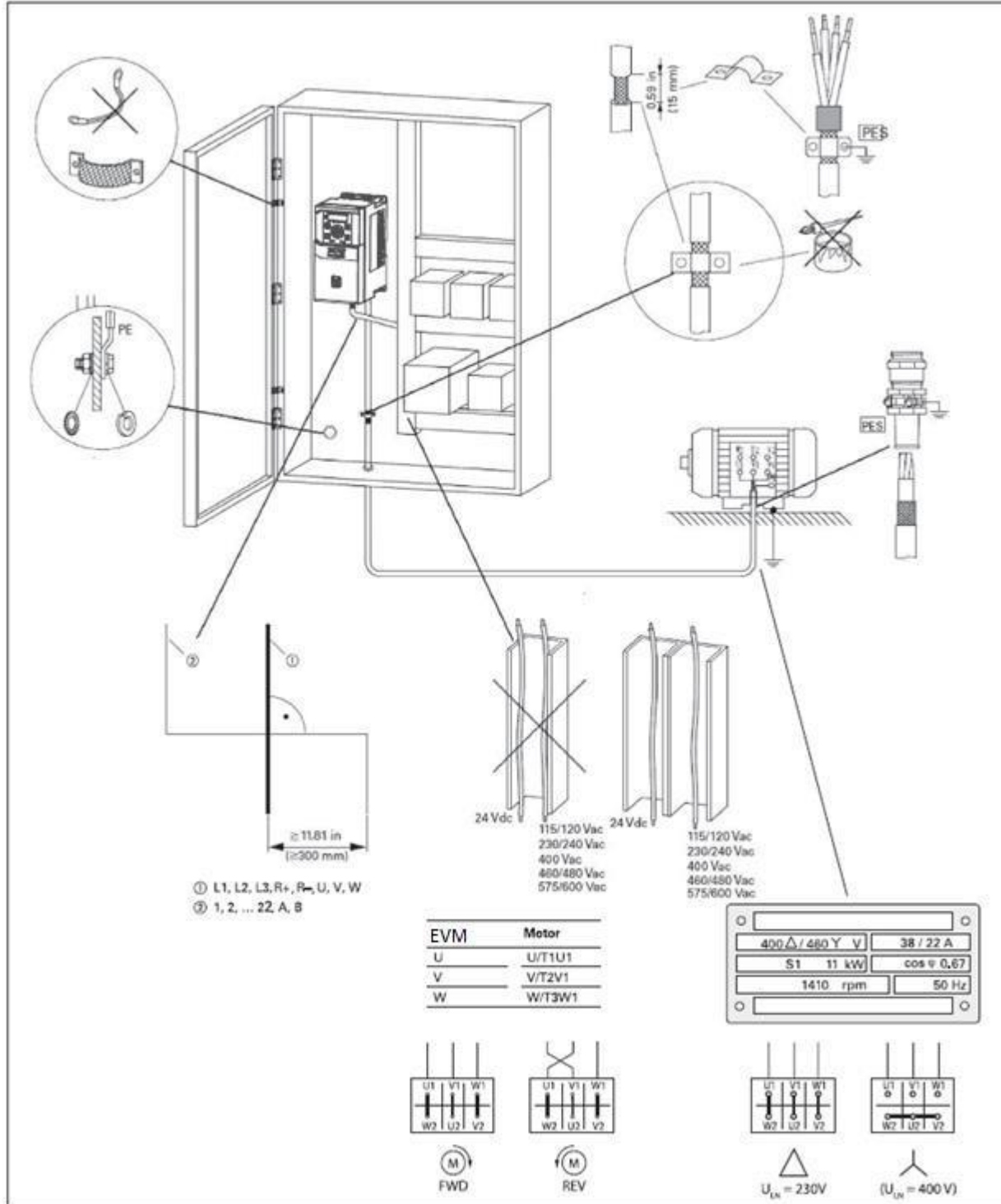

Figure 15 EVM Installation Overview

Electrical Installation

Wiring Selection

Power and Motor leads

Motor cable connections are made to terminals U, V, and W.

When selecting cables for power and motor leads, the following requirements must be followed:

- Use UL approved heat-resistant copper cables only
- 75 °C or higher for all units rated
- Line voltage/mains should be Class 1 wire only outside North America
- Refer to Appendix E for cable sizing guidelines

Lines and Motor Cable Installation

The input line and motor cables must be sized in accordance with the EVM drive's rated input and output current.

If motor temperature sensing is used for overload protection, the output cable size may be selected based on the motor specifications.

Maximum symmetrical supply current is 100,000 A RMS for all size EVM drives.

Input protection

Input protection devices are rated based on EVM drives rated input and output current.

- For UL and cUL/CSA, refer to Appendix E for proper sizing.
- For gG/gL (IEC 60269-1), also refer to Appendix E for proper sizing.

Cable Routing

If conduit is being used for wiring, use separate conduits for line voltage (mains), motor cables and all interface/control wiring. To meet the UL requirements, if conduit is being used for wiring, the enclosure openings provided for conduit connections in the field shall be closed by UL listed conduit fittings with the same type rating (Type 1) as the enclosure.

Avoid running motor cables alongside or parallel to any other wiring. If it is necessary to run motor cables with other wiring, then maintain spacing between motor cables and other wiring.

Wiring the VFD

If three or more motors are used on one VFD, each motor must have its own over current protection.

Note: Do not wire motor leads to R+, R-. This will cause damage to the drive.

Note: Actual layout may vary slightly by frame.

Ground wiring

- Run motor cables in separate conduit
- **DO NOT RUN CONTROL WIRES** in same conduit

- Cables and fuse are sized per Appendix E
- Provide dedicated wire for low impedance ground between drive and motor as shown on Figure 17. DO NOT USE conduit as ground

Figure 16 Drive Grounding

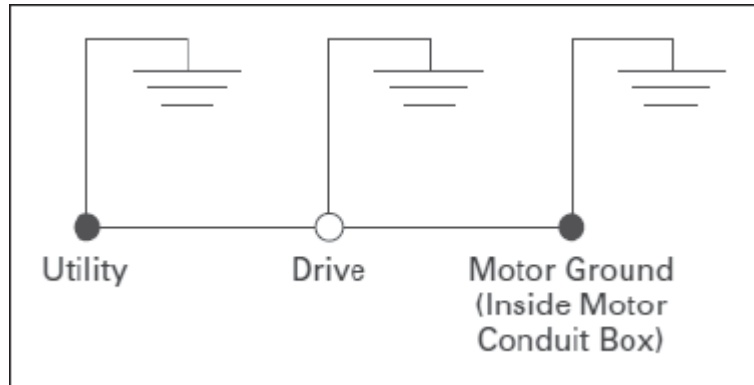

Checking the cable and motor insulation

1. Check the motor cable insulation as follows:
 - Disconnect the motor cable from terminals U, V and W of the EVM Series drive and from the motor
 - Measure the insulation resistance of the motor cable between each phase conductor as well as between each phase conductor and the protective ground conductor
 - The insulation resistance must be >1M ohm
2. Check the input power cable insulation as follows:
 - Disconnect the input power cable from terminals L1, L2 and L3 of the EVM Series drive and from the utility line feeder
 - Measure the insulation resistance of the input power cable between each phase conductor as well as between each phase conductor and the protective ground conductor
 - The insulation resistance must be >1M ohm
3. Check the motor insulation as follows:
 - Disconnect the motor cable from the motor and open any bridging connections in the motor connection box
 - Measure the insulation resistance of each motor winding. The measurement voltage must equal at least the motor nominal voltage but not exceed $(1.1 * 2 * \text{Sqrt}(2) * V_{dc})$.
 - The insulation resistance must be >1M ohm

Input Connections and Configuration

The EVM series drives can be connected and operated with all control-point grounded AC power networks.

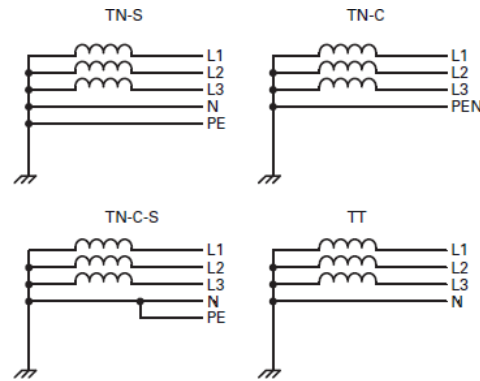

Figure 17 AC power networks types

The EVM drive can be applied to all types of power networks above. If multiple VFD with single-phase supplies are to be connected, a symmetrical distribution to the three external conductors shall be taken into account. In addition, the total current of all single-phase consumers is not to cause an overload of the neutral conductor (N-conductor). The connection and operation of VFD to asymmetrically grounded TN networks (phase-grounded delta network “Grounded Delta”, USA) or neutral point ungrounded or high-resistance grounded (>30 ohms) IT networks is only conditionally permissible. In these networks above-mentioned, the internal interference suppression filter of VFD must be disconnected. The required filtering for EMC (electromagnetic compatibility) is no longer present (degrade to level C4). Measures for EMC are mandatory in a drive system in order to meet the legal requirements for EMC and low voltage regulations. Good grounding measures are a prerequisite for the effective insert of further measures such as shielding of filters. Without respective grounding measures, further steps are superfluous.

Input Voltage and Frequency

The standardized input voltages (IEC 60038, VDE017-1) for energy suppliers (EVU) guarantee the following conditions at the transition points:

- Deviation from the rated value of voltage: Max. +10%/-15%
- Deviation in voltage phase balance: Max. $\pm 3\%$
- Deviation from rated value of the frequency: Max. $\pm 5\text{Hz}$

The board tolerance band of the EVM drives considers the rated value for

European as (EU: ULN = 230 V/400 V, 50 Hz),

American as (USA: ULN = 240 V/480 V, 60 Hz) and

Canada as (CAN: ULN = 600 V, 60 Hz) standard voltages:

- Make a direct connection to the input (bypass)

Observe the technical data and connection requirements. For additional information, refer to the equipment nameplate or label at the VFD and the documentation. Any other usage constitutes improper use.

Input Voltage Balance

Due to the uneven loading on the conductor and with the direct connection of greater power ratings, deviations from the ideal voltage form and asymmetrical voltages can be caused in three-phase AC power networks. These asymmetric divergences in the input voltage can lead to different loading of the diodes in input rectifiers with three-phase supplied frequency inverters, and as a result, an advance failure of this diode. In the project planning for the connection of three-phase supplied VFD, consider only AC power networks that handle permitted asymmetric divergences in the **input voltage $\leq +3\%$** .

If this condition is not fulfilled, or symmetry at the connection location is uncertain, the use of an assigned AC choke is recommended.

Total Harmonic Distortion (THD)

Non-linear consumers (loads) in an AC supply system produce harmonic voltages that again result in harmonic currents. These harmonic currents at the inductive and capacitive reactance of a mains supply system produce additional voltage drops with different values that are then overlaid on the sinusoidal mains voltage and result in distortions. In supply systems, this form of “noise” can give rise to problems in an installation if the sum of the harmonics exceeds certain limit values. Non-linear consumers (harmonics producers) include for example:

- Induction and arc furnaces, welding devices
- Current converters, rectifiers and inverters, soft starters, variable frequency drives
- Switched-mode power supply units (computers, monitors, lighting), uninterruptible power supply (UPS)

The THD value (THD = Total Harmonic Distortion) is defined in standard IEC/EN 61800-3 as the ratio of the rms value of all harmonic components to the rms value of the fundamental frequency. It is given in percent of the total value.

$$\text{THD} = \frac{\sqrt{U_2^2 + U_3^2 + U_4^2 + \dots + U_n^2}}{U_1} \times 100\%$$

U_1 — *fundamental component*

U_n — n^{th} *order harmonic component*

The THD value of the harmonic distortion is stated in relation to the rms value of the total signal as a percentage. On a variable frequency drive, the total harmonic distortion is greater than 100%.

Reactive Power Compensation Devices

Special compensation measures on the power supply side is not required for EVM drives, which take on very little reactive power of the fundamental harmonics from the AC power supply network ($\cos\phi \sim 0.98$). In the AC power networks with non-choked reactive current compensation devices, current deviations can enable parallel resonance and undefinable circumstances. In the project planning for the connection of VFD to AC power networks with undefined circumstances, please consider using AC chokes.

EMC Installation

The responsibility to meet the local system EMC limit values and electromagnetic compatibility requirements is the responsibility of the end user or the system operator. The operator must also take measures to minimize or remove emissions in the environment concerned. He must also use means to increase the interference immunity of the system devices.

In a drive system (PDS) with VFD, you should take measures for electromagnetic compatibility (EMC) while doing your planning, because changes or improvements to the installation site, which are required in the installation or while mounting, are normally associated with additional higher costs.

The technology and system of a VFD cause the flow of high frequency leakage current during operation. All grounding measures must therefore be implemented with low impedance connections over a large surface area.

With leakage currents greater than 3.5 mA, in accordance with VDE 0160 or EN 61800-5-1, either

- the protective earthing conductor must have a cross-section of at least 10 mm² Cu
- the protective earthing conductor must be open-circuit monitored, and the supply must be automatically disconnected in case of discontinuity of the protective earthing conductor, or
- the second protective earthing conductor must be fitted

For an EMC-compliant installation, we recommend the following measures:

- Installation of the VFD in a metallic, electrically conducting enclosure with a good connection to earth
- Shielded motor cables (short cable lengths)
- Ground all conductive components and housings in a drive system using as short a line as possible with the greatest possible cross-section (Cu-braid)

EMC measures in the control panel

For EMC-compatible installation, connect all metallic parts of the device and the switching cabinet together over broad surfaces and so that high-frequencies will be conducted. Mounting plates and cabinet doors should make good contact and connected with short HF-braided cables. It is recommended to avoid using painted surfaces (anodized, chromized). An overview of all EMC measures is provided in Figure 19.

Install the VFD as directly as possible (without spacers) on a metal plate (mounting plate). Route input and motor cables in the switch cabinet as close to the ground potential as possible. This is because free moving cables act as antennas.

When laying HF cables (for example, shielded motor cables) or suppressed cables (for example, input supply cables, control circuit and signal cables) in parallel, a minimum clearance of 11.81 in (300 mm) is recommended in order to prevent the radiation of electromagnetic energy. Separate cable routing is also recommended when large voltage potential differences are involved. Any necessary crossed cabling between the control signal and power cables should be implemented at right angles (90 degrees).

It is recommended to never lay control or signal cables in the same duct as power cables. Analog signal cables (measured, reference and correction values) should be shielded.

Figure 18 EMC Compliant Setup

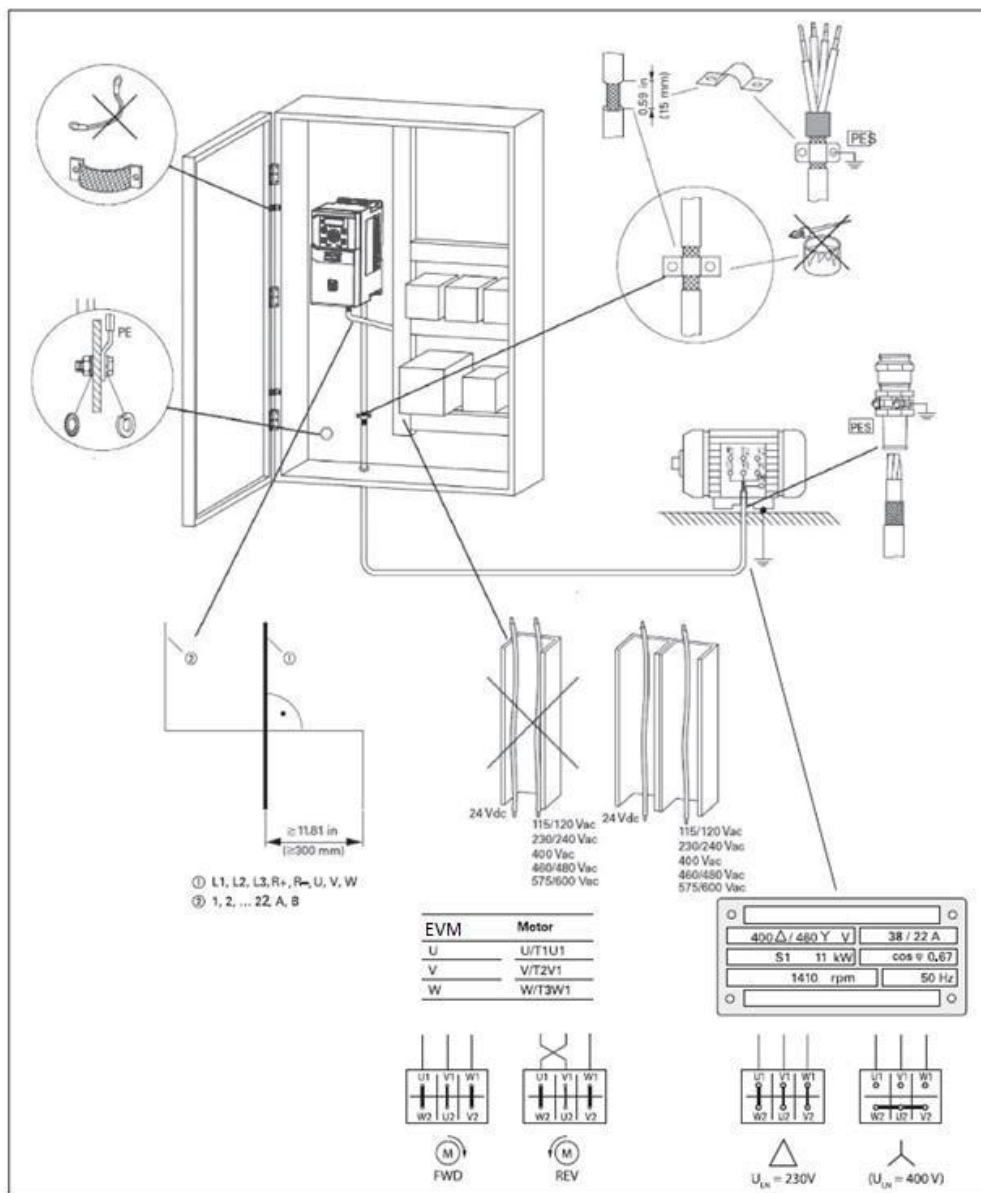

Earthing

The ground connection (PE) in the cabinet should be connected from the input supply to a central earth point (mounting plate). All protective conductors should be routed in star formation from this earth point and all conductive components of the PDS (VFD , motor reactor, motor filter, main choke) are to be connected.

Avoid ground loops when installing multiple VFD in one cabinet. Make sure that all metallic devices that are to be grounded have a broad area connection with the mounting plate.

Screen Earth Kit

Cables that are not shielded work like antennas (sending, receiving). Make sure that any cables that may carry disruptive signals (for example, motor cables) and sensitive cables (analog signal and measurement values) are shielded apart from one another with EMC-compatible connections.

The effectiveness of the cable shield depends on a good shield connection and a low shield impedance. It is recommended to use only shields with tinned or nickel-plated copper braiding. Braided steel shields are unsuitable. Control and signal lines (analog, digital) should be grounded on one end, in the immediate vicinity of the supply voltage source (PES).

Installation in corner-grounded network and IT system

Corner grounded and IT system are allowed for all the drive types.

In these circumstances the EMC protection class must be changed to level C4. This is done by removing the built-in EMC/MOV screws with a simple procedure described below.

Remove the main cover of the AC drive and remove the EMC/MOV screws depending on frame size (see Figure 20-21). Once the screw is removed, it can be reconnected to re-engage the EMC protection.

Figure 19 Location of the EMC/MOV screw in FR1

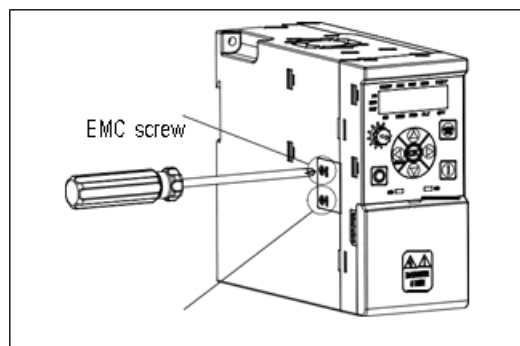
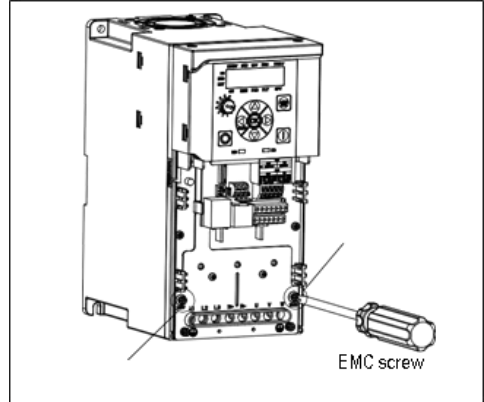

Figure 20 Location of the EMC/MOV screws in FR2-4



NEMA 1 Kits

NEMA 1 kits can be installed on all EVM drives. These NEMA 1 kits are composed of the conduit box, fan cover and all screws to mount them as shown on Figure 22. NEMA 1 kit part numbers are shown below. For additional information on installing the NEMA 1 kits, please see Appendix D.

Figure 21 NEMA 1 Kits

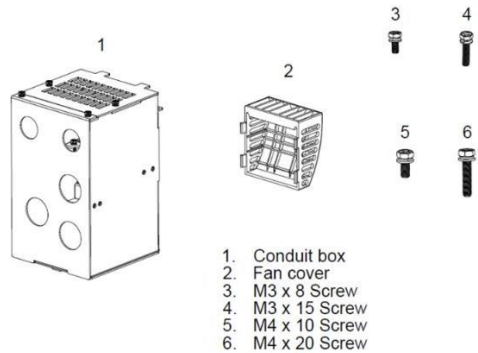

Copeland Part Number	Description
962-0009-00	EVM FR1 NEMA 1 Kit
962-0010-00	EVM FR2 NEMA 1 Kit
962-0011-00	EVM FR3 NEMA 1 Kit
962-0012-00	EVM FR4 NEMA 1 Kit
962-0054-00	EVM FR1 Plenum Rated NEMA 1 Kit
962-0055-00	EVM FR2 Plenum Rated NEMA 1 Kit
962-0056-00	EVM FR3 Plenum Rated NEMA 1 Kit
962-0057-00	EVM FR4 Plenum Rated NEMA 1 Kit

Mounting and Space Requirements

Table 14 shows the required space and cooling air requirements for each drive. For complete mounting instructions see Appendix D.

Standard Mounting Instructions

- Select the mounting location based on requirements listed in this chapter
- Mounting surface must be a flat, non-flammable surface. Mounting orientation can be vertical, horizontal or inclined (refer to mounting orientation illustration **Figure 23**).
- DIN rail mounting is only applicable for vertical mounting, while screw mounting is applicable for vertical mounting, horizontal mounting and inclined mounting.
- EVM Series drives may be mounted side-by-side or stacked vertically. (see *Note below)
- Surface must be strong enough to support the drive and not subject to excessive motion or vibration
- Mark the location of the mounting holes on the mounting surface
- Using fasteners appropriate to your VFD and mounting surface, securely attach the VFD to the mounting surface using all mounting hole locations

*Note: When mounting one unit above the other, the lower unit air outlet must be directed away via NEMA 1 Kit from the inlet air used by the upper one. The clearance between the upper and lower unit should equal C + D on Table 14.

Figure 22 Mounting Orientation

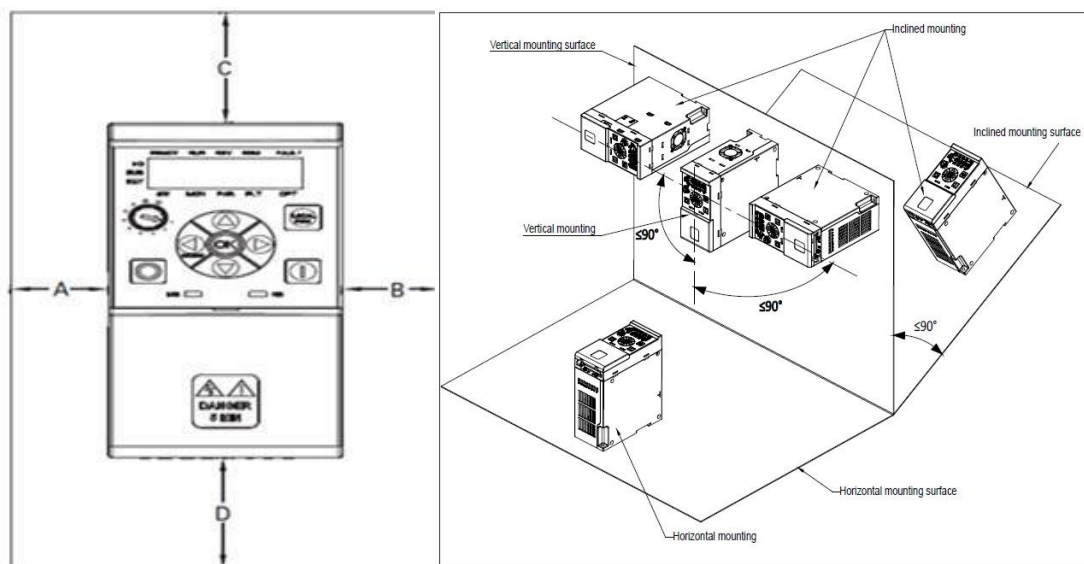

*Note: If Nema 1 Kit is used, Drive must be upright

Table 14 Space and Cooling Air Requirements

Input Voltage	Frame Size	Output Rating	Mounting Clearance				Air Flow Required
		Current Amps	A In (mm)	B In (mm)	C In (mm)	D In (mm)	CFM (m3/h)
100VAC to 120VAC 50/60hz 1 phase	FR1	2.5	0	0	1.97 (50)	1.97 (50)	14.83 (25.2)
		4.8	0	0	1.97 (50)	1.97 (50)	14.83 (25.2)
	FR2	6.9	0	0	1.97 (50)	1.97 (50)	24.72 (42)
		7.8	0	0	1.97 (50)	1.97 (50)	24.72 (42)
200VAC to 240VAC 50/60hz 1 phase	FR1	2.5	0	0	1.97 (50)	1.97 (50)	14.83 (25.2)
		4.8	0	0	1.97 (50)	1.97 (50)	14.83 (25.2)
		7.8	0	0	1.97 (50)	1.97 (50)	14.83 (25.2)
	FR2	11	0	0	1.97 (50)	1.97 (50)	24.72 (42)
		17.5	0	0	1.97 (50)	1.97 (50)	24.72 (42)
FR3	25.3	0	0	1.97 (50)	1.97 (50)	42.37 (72)	
200VAC to 240VAC 50/60hz 3 phase	FR1	2.5	0	0	1.97 (50)	1.97 (50)	14.83 (25.2)
		4.8	0	0	1.97 (50)	1.97 (50)	14.83 (25.2)
		7.8	0	0	1.97 (50)	1.97 (50)	14.83 (25.2)
		11	0	0	1.97 (50)	1.97 (50)	14.83 (25.2)
	FR2	17.5	0	0	1.97 (50)	1.97 (50)	24.72 (42)
		25.3	0	0	1.97 (50)	1.97 (50)	24.72 (42)
	FR3	32.2	0	0	1.97 (50)	1.97 (50)	42.37 (72)
	FR4	48.3	0	0	1.97 (50)	1.97 (50)	75.56 (128.4)
62.1		0	0	1.97 (50)	1.97 (50)	75.56 (128.4)	
380VAC to 480VAC 50/60hz 3 phase	FR1	2.2	0	0	1.97 (50)	1.97 (50)	14.83 (25.2)
		4.3	0	0	1.97 (50)	1.97 (50)	14.83 (25.2)
		5.6	0	0	1.97 (50)	1.97 (50)	14.83 (25.2)
		7.6	0	0	1.97 (50)	1.97 (50)	14.83 (25.2)
	FR2	12	0	0	1.97 (50)	1.97 (50)	37.43 (63.6)
		16	0	0	1.97 (50)	1.97 (50)	37.43 (63.6)
		23	0	0	1.97 (50)	1.97 (50)	37.43 (63.6)
	FR3	31	0	0	1.97 (50)	1.97 (50)	58.61 (99.6)
	FR4	38	0	0	1.97 (50)	1.97 (50)	57.56 (97.8)
46		0	0	1.97 (50)	1.97 (50)	57.56 (97.8)	
525VAC to 600VAC 50/60hz 3 phase	FR2	7.5	0	0	1.97 (50)	1.97 (50)	37.43 (63.6)
		10	0	0	1.97 (50)	1.97 (50)	37.43 (63.6)
		13.5	0	0	1.97 (50)	1.97 (50)	37.43 (63.6)
	FR3	18	0	0	1.97 (50)	1.97 (50)	58.61 (99.6)
	FR4	22	0	0	1.97 (50)	1.97 (50)	57.56 (97.8)
		27	0	0	1.97 (50)	1.97 (50)	57.56 (97.8)

DRIVE SELECTION

***For Permanent Magnet Scrolls (BPM) , please reach out to your Copeland Rep**

General Drive Sizing

For the Copeland™ EVM series VFD the follow sizing recommendations should be followed to pick the proper variable frequency drives for the application. This will make sure the drive has enough power for the application and it also follows the NEC guidelines.

Compressors

Step 1: Find minimum current output rating

Example Compressor: ZR48KCE-TF5 (MCC 23; or Max Op. Cur 18.5 can be found in OPI)

For Compressor Application where the Drive is used as circuit protection

Per NEC Article 440 current rating must be 15% over the RLA load

$(MCC/1.56)*1.15=$ minimum current output rating of the drive needed

Ex: $(23/1.56)*1.15=$ 17 Amps

OR

For Compressor Application where drive is not used as circuit protection (circuit breaker already installed)

Find the Max Operating Current of the compressor (on OPI or compressor nameplate)

Max OP Cur.*1.15= minimum current output rating of the drive needed

Ex: $18.5*1.15=$ 21.3 Amps

Step 2: Verify compressor approved max frequency in **Table 15**.

Example Compressor: ZR48KCE-TF5 (rated for 60Hz 3500 RPM found in OPI)

Step 3: If max frequency found in step 2 is larger than the rated frequency of the compressor do the following. If it is not larger use the current output you found in Step 1 to select the drive.

Calculate rotation speed

Rotation Speed=Max Freq(from Table 15)*(2/# of poles)*60

Ex: $65\text{Hz} * (2/2)*60=$ 3900 RPM

Then find percent increase from rated RPM to the max RPM

$$\frac{\text{Max RPM} - \text{Rated RPM}}{\text{Rated RPM}} \times 100 = \text{Percent Increase}$$

Ex: $\frac{3900-3500}{3500} \times 100 = 11.4\%$

Take the current found in step 1 based on application and multiply it by percentage increase found

Ex: $17 \text{ amps} + (17*11.4\%)=$ 19 amps

19 amps would be the new minimum current output rating of the drive needed

Table 15 Approved Frequency for Copeland™ Fixed Speed Compressors

Compressor Family	Frequency Range
3D	25 hz to 60 hz
4D	
6D	
4MSLS	25/30 hz to 60/70 hz <small>*see AE 1396</small>
4MTLS	
ZB*KA	45 hz to 60 hz
ZF*KA	
ZS*KA	
ZS*KA	
ZB*K5 Ref K5	
ZF*K5 Ref K5	
ZF*K4 Quantum	
ZS*K4 Quantum	
ZB*KA Quest	
ZB*KC Quest	
ZF*K4 Quest	
ZF*KV Quest EVI	
ZS*K4 Quest	
ZP235KCE to ZP485KCE	
ZR250KCE to ZR380KCE	
ZP104KCE to ZP122KCE	45 hz to 65 hz
ZP23K3E to ZP41K3E	
ZR22K3E to ZR48K3E	
ZR28KC to ZR48KC	
ZR45KCE to ZR48KCE	
ZP50K3E to ZP57K3E	
ZP61KCE to ZP91KCE	
ZR54KC to ZR81KC	
ZR49KCE to ZR81KCE	
ZR52K3 to ZR61K3	
ZP103KCE to ZP182KCE	
ZR84KCE to ZR190KCE	
ZP14K5E to ZP61K5E	
ZP10K6 to ZP54K6	

Pumps and Fans

Step 1: Find the full load amps (FLA) on the nameplate & the Power Factor (PF)

Example: 5 HP motor 208V – FLA: 16.7; PF=0.85; 1800 RPM @60Hz; 4 pole

Step 2: Find Minimum current rating needed

FLA*1.15 = Min. Current Output Rating of the drive needed

Example: 16.7*1.15=19.2

Step 3: To run the product at a higher speed than what is rated follow Step 4 similar to the compressor.

*The original equipment manufacturer should be contacted to verify the frequency range that is ok to run with for the product.

Step4: If max frequency found in Step 3 is larger than the rated frequency of the product motor do the following. If it is not larger, use the current output you found in Step 2 to select the drive.

Calculate rotation speed

Rotation Speed=Max Freq*(2/# of poles)*60

Ex: 65Hz *(2/4)*60= 1950 RPM

Then find percent increase from rated RPM to the max RPM

$$\frac{\text{Max RPM} - \text{Rated RPM}}{\text{Rated RPM}} \times 100 = \text{Percent Increase}$$

Ex: $\frac{1950-1800}{1800} \times 100 = 8.3\%$

Take the current found in step 1 based on application and multiply it by percentage increase found

Ex: 19.2 amps + (19.2*8.3%)= 20.8 amps

20.8 amps would be the new minimum current output rating of the drive needed

STARTUP AND COMMISSIONING

A quick start guide is available on **Appendix F**.

Startup Wizard Page

In the Start-up Wizard, you will be prompted for essential information needed by the drive so that it can start controlling your process. In the Wizard, you will need the following keypad buttons:

Startup Wizard

In the Startup Wizard, you will be prompted for essential information needed by the drive so that it can start controlling your process. In the Wizard, you will need the following keypad buttons:

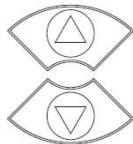

Up/down buttons.
Use these to changes value(s).



OK button.
Confirm selection with this button, and enter into next question.



Left/back/reset button.
If this button was pressed at the first question, the Start-up Wizard will be cancelled.

If this button is pressed in any step on the Start-up Wizard, the Start-up Wizard will be cancelled.

Once you have connected power to your EVM variable frequency drive, and the Startup Wizard is enabled, follow these instructions to easily set up your drive.

Parameter	Name	Description	Min. Value	Max. Value	Default Value
P13.1.7	Parameter lock PIN	<p>The application selection can be protected against unauthorized changes with the password function. When the password function is enabled, the user will be prompted to enter a password before application changes, parameter value changes, or password changes.</p> <p>By default, the password function is not in use. If you want to activate the password, change the value of this parameter to any number between 1 and 9999.</p> <p>To deactivate the password, reset the parameter value to 0.</p>	0	9999	0

Parameter	Name	Description	Min. Value	Max. Value	Default
P1.1**	Minimum Frequency	These define the frequency limits of the frequency converter. The maximum value for these parameters is 400 Hz. The minimum frequency has to be below the maximum frequency level. These will limit other frequency parameter settings; preset speeds, jog speed, 4 mA fault preset speed, fire mode speed, and brake speed settings.	0.00 HZ	400.00 HZ	0.00 HZ
P1.2**	Maximum Frequency	These define the frequency limits of the frequency converter. The maximum value for these parameters is 400 Hz. The minimum frequency has to be below the maximum frequency level. These will limit other frequency parameter settings; preset speeds, jog speed, 4 mA fault preset speed, fire mode speed, and brake speed settings.	0.00 HZ	400.00 HZ	MaxFreqMFG
P1.6*	Motor Nominal Current	Motor nominal nameplate full load current. Find this value on the rating plate of the motor.	DriveNomCurrCT* 1/10 A	DriveNomCurrCT* 2 A	DriveNomCurrCT A
P1.7*	Motor Nominal Speed	Motor nominal nameplate base speed. Find this value on the rating plate of the motor.	300 RPM	20,000 RPM	MotorNomSpeed MFG
P1.8*	Motor Power Factor	Motor nominal nameplate full load power factor. Find this value on the rating plate of the motor.	0.3	1.0	0.85
P1.9*	Motor Nominal Voltage	Motor nominal nameplate base voltage. Find this value on the rating plate of the motor.	180 V	690 V	487 V
P1.10*	Motor Nominal Frequency	Motor nominal nameplate base frequency. Find this value on the rating plate of the motor. This parameter sets the field weakening point (P8.4) to the same value.	8.00 HZ	400.00 HZ	MotorNomFreqM FG
P1.3**	Acceleration Time 1	The time required for the output frequency to accelerate from zero frequency to maximum frequency (P1.2). When accelerating from different frequency levels, the acceleration time will be a fraction of the total ramp time. See Figure 19.	0.10 s	3000.00 s	20.00 s
P1.4**	Deceleration Time 1	The time required for the output frequency to decelerate from maximum frequency (P1.2) to zero frequency. When decelerating from different frequency levels, the deceleration time will be a fraction of the total time. See Figure 19.	0.10 s	3000.00 s	20.00 s

Parameter	Name	Description	Min. Value	Max. Value	Default
P1.13**	Remote Control Place	Selects where the drive will look for the start command in the remote location: I/O terminals would be from the digital hard-wired inputs; fieldbus would be a communication bus; and keypad display will indicate what mode is selected. 0 = IO terminal 1 = Fieldbus 3 = Keypad	NA	NA	0
P1.14***	Remote Reference	This parameter determines the reference for remote 1 control mode. This value can be fed from an analog input, keypad, or fieldbus reference signal 0 = AI 1 = Drive reference pot; 2 = AI joystick 3 = Motor pot 4 = Maximum frequency 5 = PI control output 6 = Keypad 7 = Fieldbus reference	NA	NA	0
P13.5.3	Keypad Lock Pin	The keypad can be protected against unauthorized changes with the keypad lock function after no keys are pressed after five minutes. When the password function is enabled, the user will be prompted to enter a password before the keypad display parameter or response to key press except up/down/left/right. By default, the password function is not in use. If you want to activate the password, change the value of this parameter to any number between 1 and 9999. To deactivate the password, reset the parameter value to 0.	0	9999	0
P11.6.1	Bluetooth Enabled	Enable or Disable Bluetooth 0 = Disabled 1 = Enable.	NA	NA	0

* Parameter value can only be changed after the drive has stopped.

** Parameter value will be set to be default when changing macros

*** Both notes above will apply.

Now the Start-up Wizard is done. It will not show again at the next power up. If you want to reset it, please select it from the main menu (“Start-up Wizard”).

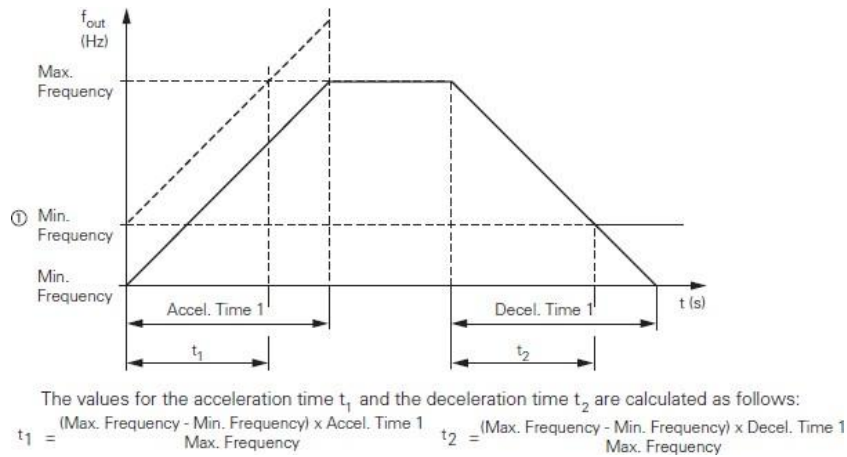

Figure 23 Acceleration and Deceleration time

COMMUNICATION

Communication Features

All EVM drives has both Modbus RTU and Bluetooth capability as standard. However, the EVM-Pro is capable of using other communication protocols as shown on Table 16. There also other optional communication protocols that are available.

Table 16 Communication Features

Protocols	EVM	EVM-Pro	Onboard/Optional
Modbus RTU	•	•	Onboard
BACnet MSTP		•	Onboard
Ethernet/IP		•	Onboard
Modbus TCP		•	Onboard
PROFIBUS		•	Optional via Card Slot
CANopen		•	Optional via Card Slot
BACnet IP		•	Onboard
Bluetooth	•	•	Onboard

Optional Communication Cards

The EVM drive is equipped with a slot on the side where optional communication cards can be installed.

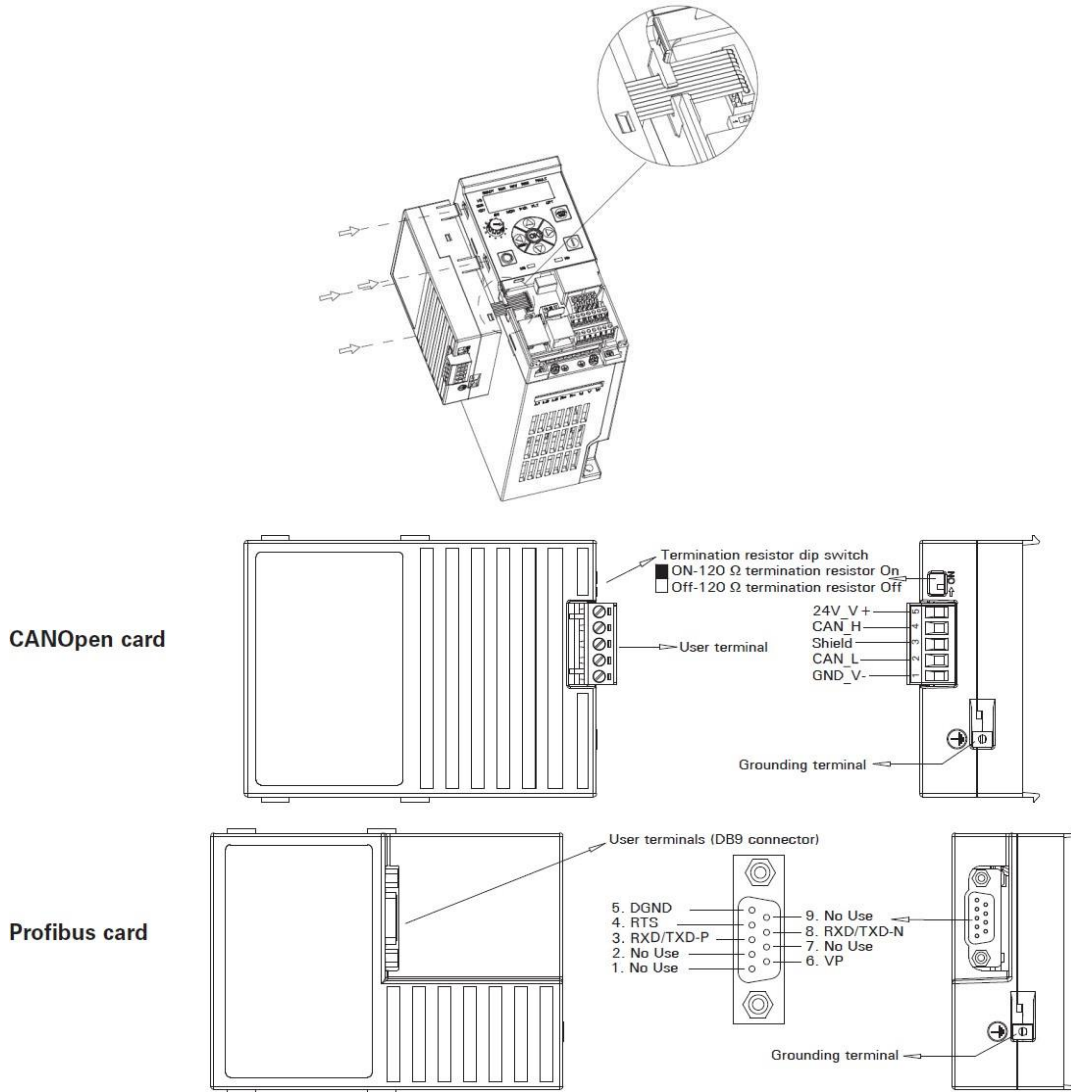

For steps on installation of the communication card, please refer to Appendix G.

Modbus RTU Onboard Communication

The drive product can be controlled via Modbus® RTU through the on-board RS-485 terminals. Figure 25 shows a typical arrangement with a host computer (master) and any number maximum 31 slaves of frequency inverters. Each frequency inverter has a unique address in the network. This addressing is executed individually for each VFD via the communication parameters. The electrical connection between master and the slaves connected in parallel are implemented via the serial interface A-B (A = positive, B = negative) with a shielded RS-485 twisted pair cable.

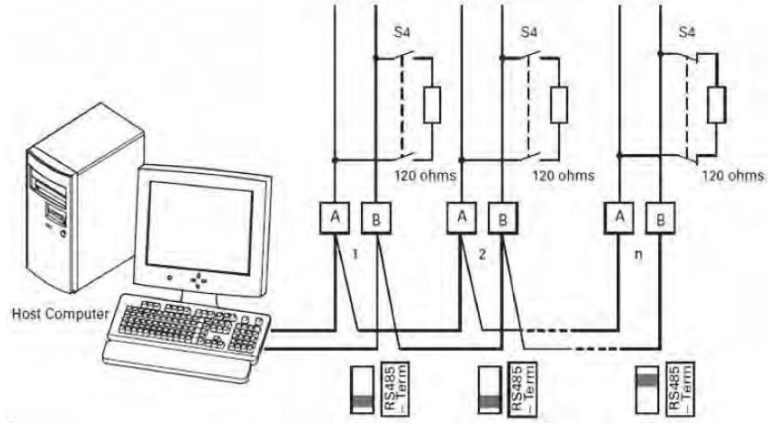

Figure 24 Typical Arrangement with Host Computer (Master)

Modbus RTU Specifications

Communication Board Connections

Table 17 shows the communication board connections. See Appendix I for additional information.

ITEM	DESCRIPTION
Interface	
Data Transfer Method	RS-485, half duplex
Transfer Cable	Twisted pair (1 pair and shield)
Electrical Isolation	

Table 17 Communication Board Connections

Connection Options

The RS-485 communication port is connected via the A and B terminals on the drives control board. See Figure 26 and 27 below for the terminal locations.

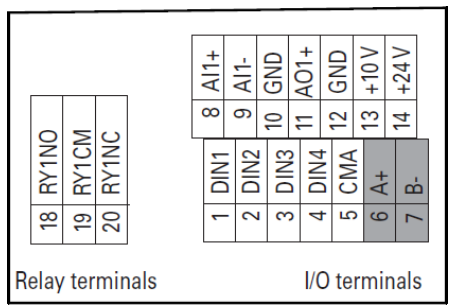

Figure 25 EVM Modbus Terminals

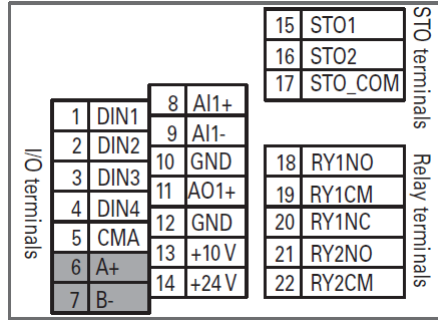

Figure 26 EVM-Pro Modbus Terminals

System Integration

EVM Drive can be integrated with Supervisory Controllers via Communications ports. Expansion cards are available for other protocols. Parametric controllers can also be integrated to EVM drive to provide the analog input for the speed reference and Digital inputs for the operation of the EVM drive.

MAINTENANCE AND INSPECTION

EVM drives are **maintenance free**. However, external influences may affect the function and the lifespan of the drive. We therefore recommend that the devices are checked regularly, and the following maintenance measures are carried out at the specified intervals as shown on Table 18.

Maintenance	Interval
Clean cooling vents (cooling slits)	If required
Check the fan function	6-24 months (depending on the environment)
Filter in the switching cabinet doors (see manufacturer specifications)	6-24 months (depending on the environment)
Check the tightening torques of the terminals (control signal terminals, power terminals)	Regularly
Check connection terminals and all metallic surfaces for corrosion	6-24 months (depending on the environment)

Table 18 Maintenance Interval

STORAGE

If the drive is stored before use, suitable ambient conditions must be ensured at the site of storage:

- Storage temperature: –40 °F to 158 °F (–40 °C to 70 °C)
- Relative average air humidity: <95%, noncondensing (EN 50178)
- To prevent damage to the DC link capacitors, storage times longer than 12 months are not recommended

Charging the internal DC link capacitors

After extended storage times or extended downtimes during which no power is supplied (>12 months), the capacitors in the internal DC link must be recharged in a controlled manner in order to prevent damage. To do this, the EVM variable frequency drive must be supplied with power, with a controlled DC power supply unit, via two mains DC bus connection terminals. Please consult the factory for detailed instructions.

TROUBLESHOOTING

The EVM Series drive provides feedback during a fault condition. For each fault code, **Appendix H** provides a brief description of what is occurring and the actions to take to resolve the issue.

The contents of this publication are presented for informational purposes only and are not to be construed as warranties or guarantees, express or implied, regarding the products or services described herein or their use or applicability. Copeland and/or its affiliates (collectively "Copeland"), as applicable, reserve the right to modify the design or specifications of such products at any time without notice. Copeland does not assume responsibility for the selection, use or maintenance of any product. Responsibility for proper selection, use and maintenance of any Copeland product remains solely with the purchaser or end user.

Appendix A: List of EVM Models

Frame Size	IP Rating	Model Number	Output kW	Output Current	Input Phase	Input Voltage	Output Voltage
1	20	EVM-1222D5-E20EFN	0.37	2.5	1Ø	100-120v	200-240v
1	20	EVM-1122D5-E20ENN	0.37	2.5	1Ø	100-120v	200-240v
1	20	EVM-1124D8-E20ENN	0.75	4.8	1Ø	100-120v	200-240v
1	20	EVM-1124D8-E20EFN	0.75	4.8	1Ø	100-120v	200-240v
1	20	EVM-1222D5-E20ENN	0.37	2.5	1Ø	200-240v	200-240v
1	20	EVM-1222D5-E20EFN	0.37	2.5	1Ø	200-240v	200-240v
1	20	EVM-1224D8-E20ENN	0.75	4.8	1Ø	200-240v	200-240v
1	20	EVM-1224D8-E20EFN	0.75	4.8	1Ø	200-240v	200-240v
1	20	EVM-1227D8-E20ENN	1.5	7.8	1Ø	200-240v	200-240v
1	20	EVM-1227D8-E20EFN	1.5	7.8	1Ø	200-240v	200-240v
1	20	EVM-122025-E20EFN	5.5	25	1Ø	200-240v	200-240v
1	20	EVM-3442D2-E20ENN	0.75	2.2	3Ø	380-480v	380-480v
1	20	EVM-3442D2-N20MNN	0.75	2.2	3Ø	380-480v	380-480v
1	20	EVM-3442D2-N20MFN	0.75	2.2	3Ø	380-480v	380-480v
1	20	EVM-3442D2-E20EFN	0.75	2.2	3Ø	380-480v	380-480v
1	20	EVM-3222D5-E20ENN	0.37	2.5	3Ø	200-240v	200-240v
1	20	EVM-3222D5-N20MNN	0.37	2.5	3Ø	200-240v	200-240v
1	20	EVM-3222D5-N20MFN	0.37	2.5	3Ø	200-240v	200-240v
1	20	EVM-3222D5-E20EFN	0.37	2.5	3Ø	200-240v	200-240v
1	20	EVM-3444D3-E20ENN	1.5	4.3	3Ø	380-480v	380-480v
1	20	EVM-3444D3-N20MNN	1.5	4.3	3Ø	380-480v	380-480v
1	20	EVM-3444D3-N20MFN	1.5	4.3	3Ø	380-480v	380-480v
1	20	EVM-3444D3-E20EFN	1.5	4.3	3Ø	380-480v	380-480v
1	20	EVM-3224D8-E20ENN	0.75	4.8	3Ø	200-240v	200-240v
1	20	EVM-3224D8-N20MNN	0.75	4.8	3Ø	200-240v	200-240v
1	20	EVM-3224D8-N20MFN	0.75	4.8	3Ø	200-240v	200-240v
1	20	EVM-3224D8-E20EFN	0.75	4.8	3Ø	200-240v	200-240v
1	20	EVM-3445D6-E20ENN	2.2	5.6	3Ø	380-480v	380-480v
1	20	EVM-3445D6-N20MNN	2.2	5.6	3Ø	380-480v	380-480v
1	20	EVM-3445D6-N20MFN	2.2	5.6	3Ø	380-480v	380-480v
1	20	EVM-3445D6-E20EFN	2.2	5.6	3Ø	380-480v	380-480v
1	20	EVM-3447D6-E20ENN	3	7.6	3Ø	380-480v	380-480v
1	20	EVM-3447D6-N20MFN	3	7.6	3Ø	380-480v	380-480v
1	20	EVM-3447D6-N20MFN	3	7.6	3Ø	380-480v	380-480v
1	20	EVM-3447D6-E20EFN	3	7.6	3Ø	380-480v	380-480v
1	20	EVM-3227D8-E20ENN	1.5	7.8	3Ø	200-240v	200-240v
1	20	EVM-3227D8-N20MNN	1.5	7.8	3Ø	200-240v	200-240v
1	20	EVM-3227D8-N20MFN	1.5	7.8	3Ø	200-240v	200-240v
1	20	EVM-3227D8-E20EFN	1.5	7.8	3Ø	200-240v	200-240v
1	20	EVM-322011-E20ENN	2.2	11	3Ø	200-240v	200-240v
1	20	EVM-322011-N20MNN	2.2	11	3Ø	200-240v	200-240v
1	20	EVM-322011-N20MFN	2.2	11	3Ø	200-240v	200-240v
1	20	EVM-322011-E20EFN	2.2	11	3Ø	200-240v	200-240v
2	20	EVM-1126D9-E20ENN	1.1	6.9	1Ø	100-120v	200-240v
2	20	EVM-1126D9-E20EFN	1.1	6.9	1Ø	100-120v	200-240v
2	20	EVM-1127D8-E20ENN	1.5	7.8	1Ø	100-120v	200-240v
2	20	EVM-1127D8-E20EFN	1.5	7.8	1Ø	100-120v	200-240v

Appendix A: List of EVM Models

Frame Size	IP Rating	Model Number	Output kW	Output Current	Input Phase	Input Voltage	Output Voltage
2	20	EVM-122011-E20ENN	2.2	11	1∅	200-240v	200-240v
2	20	EVM-122011-E20EFN	2.2	11	1∅	200-240v	200-240v
2	20	EVM-344012-E20ENN	5.5	12	3∅	380-480v	380-480v
2	20	EVM-344012-N20MNN	5.5	12	3∅	380-480v	380-480v
2	20	EVM-344012-N20MFN	5.5	12	3∅	380-480v	380-480v
2	20	EVM-344012-E20EFN	5.5	12	3∅	380-480v	380-480v
2	20	EVM-344016-E20ENN	7.5	16	3∅	380-480v	380-480v
2	20	EVM-344016-N20MNN	7.5	16	3∅	380-480v	380-480v
2	20	EVM-344016-N20MFN	7.5	16	3∅	380-480v	380-480v
2	20	EVM-344016-E20EFN	7.5	16	3∅	380-480v	380-480v
2	20	EVM-322017-E20ENN	4	17	3∅	200-240v	200-240v
2	20	EVM-122017-E20ENN	4	17	1∅	200-240v	200-240v
2	20	EVM-122017-E20EFN	4	17	1∅	200-240v	200-240v
2	20	EVM-322017-N20MFN	4	17	3∅	200-240v	200-240v
2	20	EVM-322017-E20EFN	4	17	3∅	200-240v	200-240v
2	20	EVM-322017-N20MNN	4	17	3∅	200-240v	200-240v
2	20	EVM-344023-E20ENN	11	23	3∅	380-480v	380-480v
2	20	EVM-344023-N20MNN	11	23	3∅	380-480v	380-480v
2	20	EVM-344023-N20MFN	11	23	3∅	380-480v	380-480v
2	20	EVM-344023-E20EFN	11	23	3∅	380-480v	380-480v
2	20	EVM-322025-E20ENN	5.5	25	3∅	200-240v	200-240v
2	20	EVM-322025-N20MNN	5.5	25	3∅	200-240v	200-240v
2	20	EVM-322025-N20MFN	5.5	25	3∅	200-240v	200-240v
2	20	EVM-322025-E20EFN	5.5	25	3∅	200-240v	200-240v
3	20	EVM-122025-E20ENN	5.5	25	1∅	200-240v	200-240v
3	20	EVM-344031-E20ENN	15	31	3∅	380-480v	380-480v
3	20	EVM-344031-N20MNN	15	31	3∅	380-480v	380-480v
3	20	EVM-344031-N20MFN	15	31	3∅	380-480v	380-480v
3	20	EVM-344031-E20EFN	15	31	3∅	380-480v	380-480v
3	20	EVM-322032-E20ENN	7.5	32	3∅	200-240v	200-240v
3	20	EVM-322032-N20MNN	7.5	32	3∅	200-240v	200-240v
3	20	EVM-322032-N20MFN	7.5	32	3∅	200-240v	200-240v
3	20	EVM-322032-E20EFN	7.5	32	3∅	200-240v	200-240v
4	20	EVM-344038-E20ENN	18.5	38	3∅	380-480v	380-480v
4	20	EVM-344038-N20MNN	18.5	38	3∅	380-480v	380-480v
4	20	EVM-344038-N20MFN	18.5	38	3∅	380-480v	380-480v
4	20	EVM-344038-E20EFN	18.5	38	3∅	380-480v	380-480v
4	20	EVM-344046-E20ENN	22	46	3∅	380-480v	380-480v
4	20	EVM-344046-N20MNN	22	46	3∅	380-480v	380-480v
4	20	EVM-344046-N20MFN	22	46	3∅	380-480v	380-480v
4	20	EVM-344046-E20EFN	22	46	3∅	380-480v	380-480v
4	20	EVM-322048-E20ENN	11	48	3∅	200-240v	200-240v
4	20	EVM-322048-N20MNN	11	48	3∅	200-240v	200-240v
4	20	EVM-322048-N20MFN	11	48	3∅	200-240v	200-240v
4	20	EVM-322048-E20EFN	11	48	3∅	200-240v	200-240v
4	20	EVM-322062-E20ENN	15	62	3∅	200-240v	200-240v
4	20	EVM-322062-N20MNN	15	62	3∅	200-240v	200-240v
4	20	EVM-322062-N20MFN	15	62	3∅	200-240v	200-240v

Appendix A: List of EVM Models

4	20	EVM-322062-E20EFN	15	62	3∅	200-240v	200-240v
---	----	-------------------	----	----	----	----------	----------

Appendix A: List of EVM Models

Frame Size	IP Rating	Model Number	Output kW	Output Current	Input Phase	Input Voltage	Output Voltage
2	20	EVM-3557D5-E20ENN	3	7.5	3 \emptyset	575v	575v
2	20	EVM-3557D5-E20EFN	3	7.5	3 \emptyset	575v	575v
2	20	EVM-355010-E20ENN	5.5	10	3 \emptyset	575v	575v
2	20	EVM-355010-E20EFN	5.5	10	3 \emptyset	575v	575v
2	20	EVM-355013-E20ENN	7.5	13.5	3 \emptyset	575v	575v
2	20	EVM-355013-E20EFN	7.5	13.5	3 \emptyset	575v	575v
3	20	EVM-355018-E20ENN	11	18	3 \emptyset	575v	575v
3	20	EVM-355018-E20EFN	11	18	3 \emptyset	575v	575v
4	20	EVM-355022-E20ENN	15	22	3 \emptyset	575v	575v
4	20	EVM-355022-E20EFN	15	22	3 \emptyset	575v	575v
4	20	EVM-355027-E20ENN	18.5	27	3 \emptyset	575v	575v
4	20	EVM-355027-E20EFN	18.5	27	3 \emptyset	575v	575v

*The drive must be selected based on the sizing procedures enumerated on this document.

Appendix B Drive Dimensions

EVM-Pro FR1 with NEMA 1 kit Dimensions

Approximate dimensions in Inches (mm)

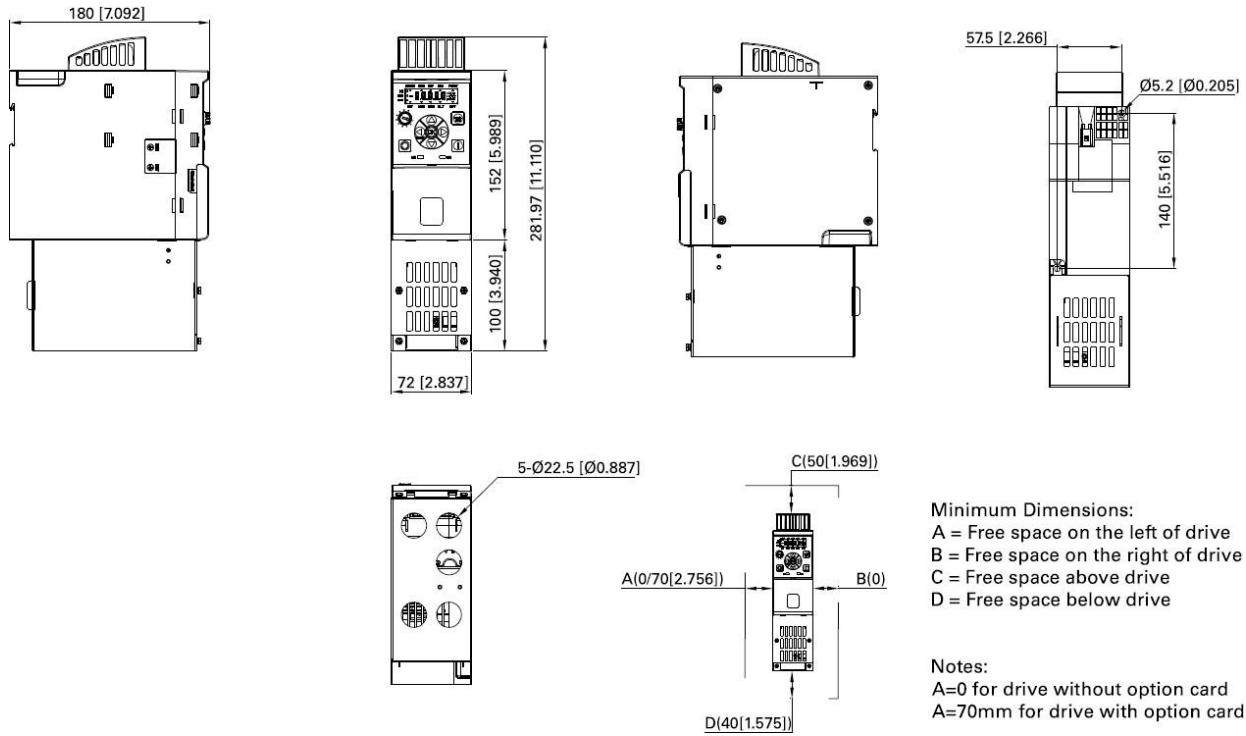

EVM FR1 with NEMA 1 kit Dimensions

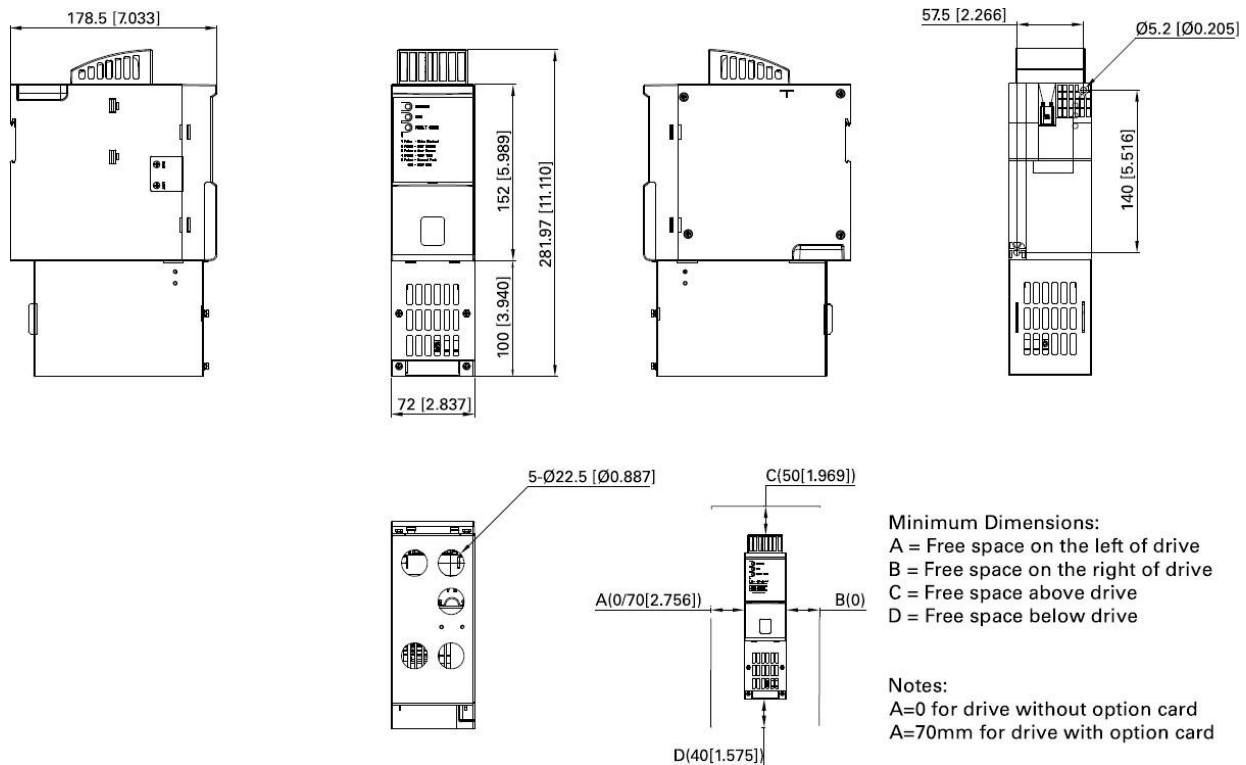

Appendix B Drive Dimensions

EVM-Pro FR2 with NEMA 1 kit Dimensions

Approximate dimensions in Inches (mm)

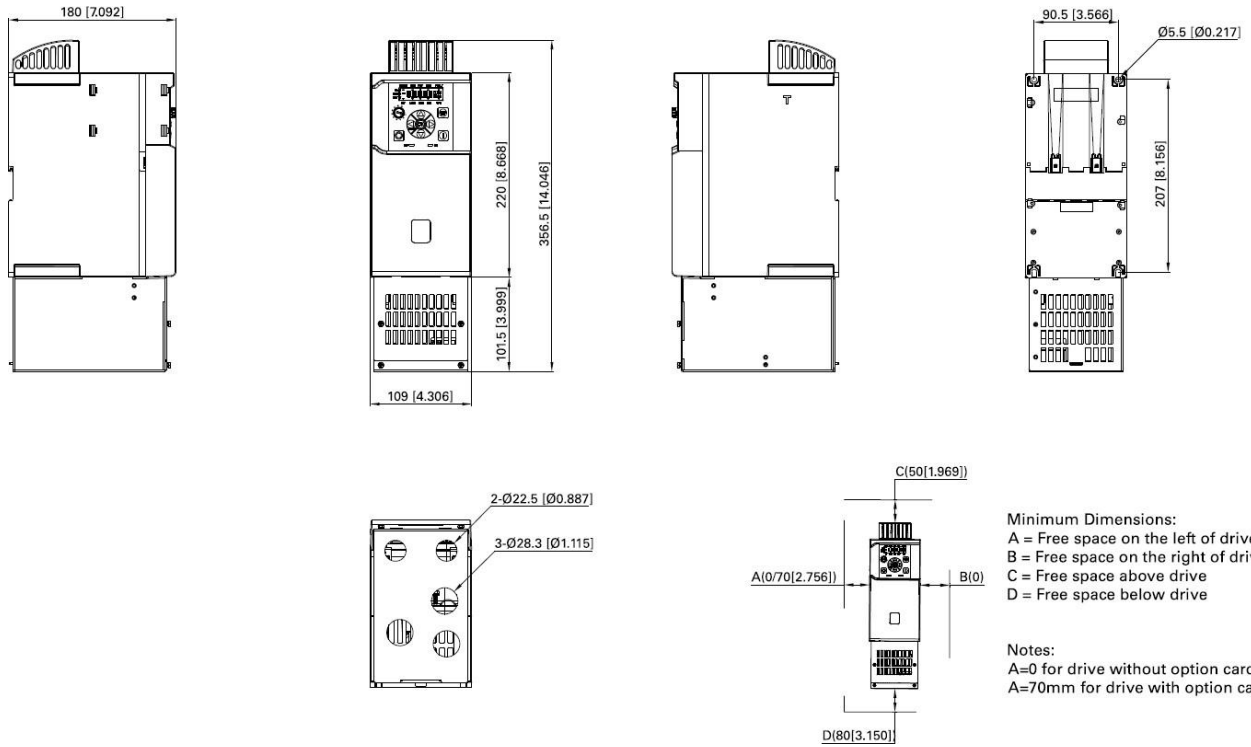

EVM FR2 with NEMA 1 kit Dimensions

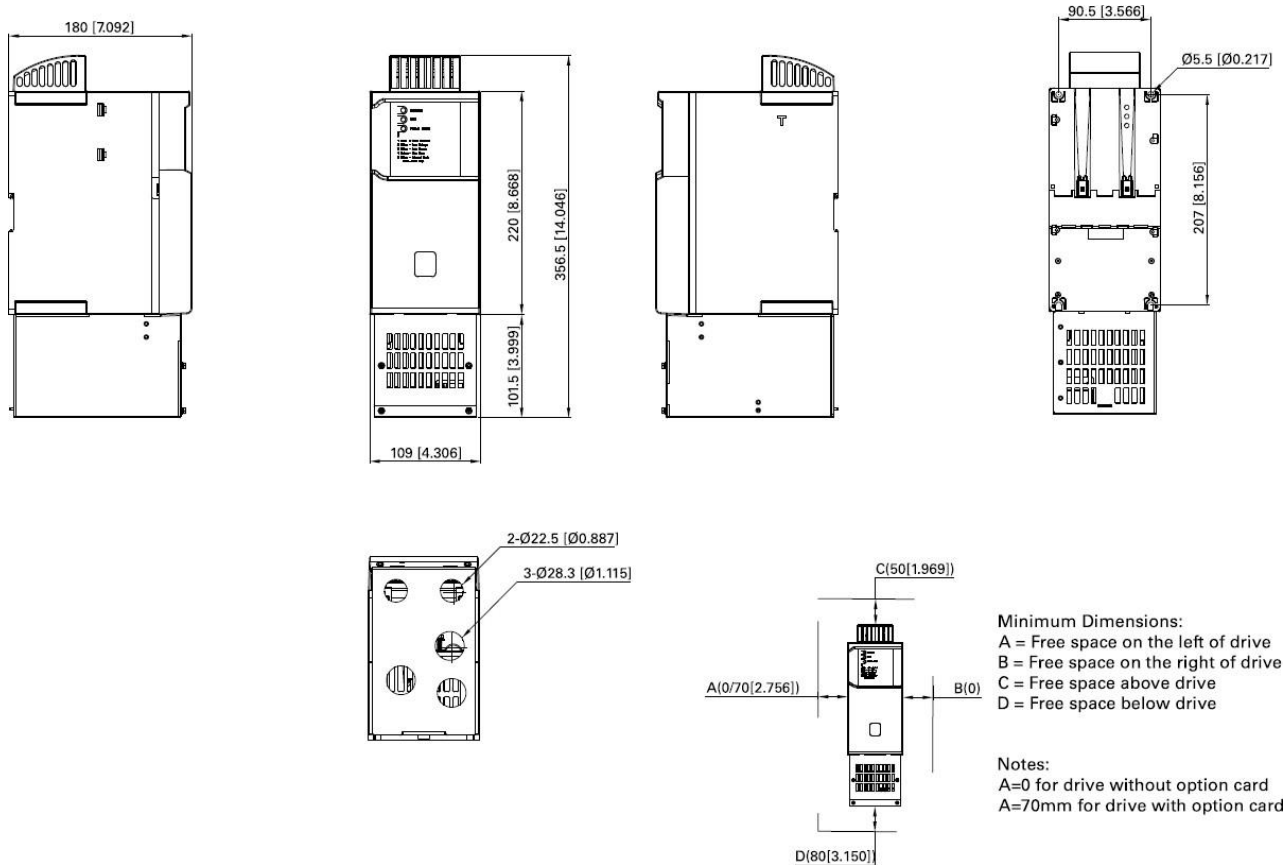

Appendix B Drive Dimensions

EVM-Pro FR3 with NEMA 1 kit Dimensions

Approximate dimensions in Inches (mm)

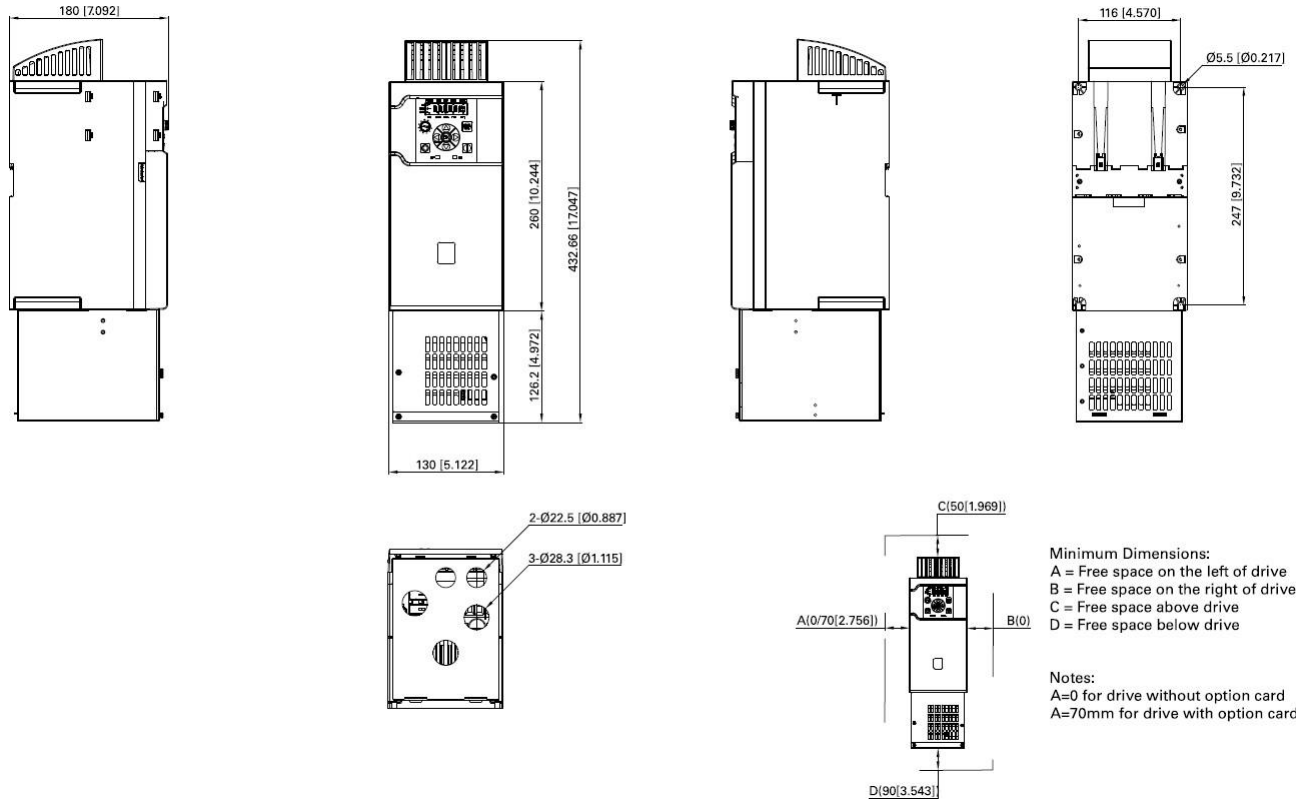

EVM FR3 with NEMA 1 kit Dimensions

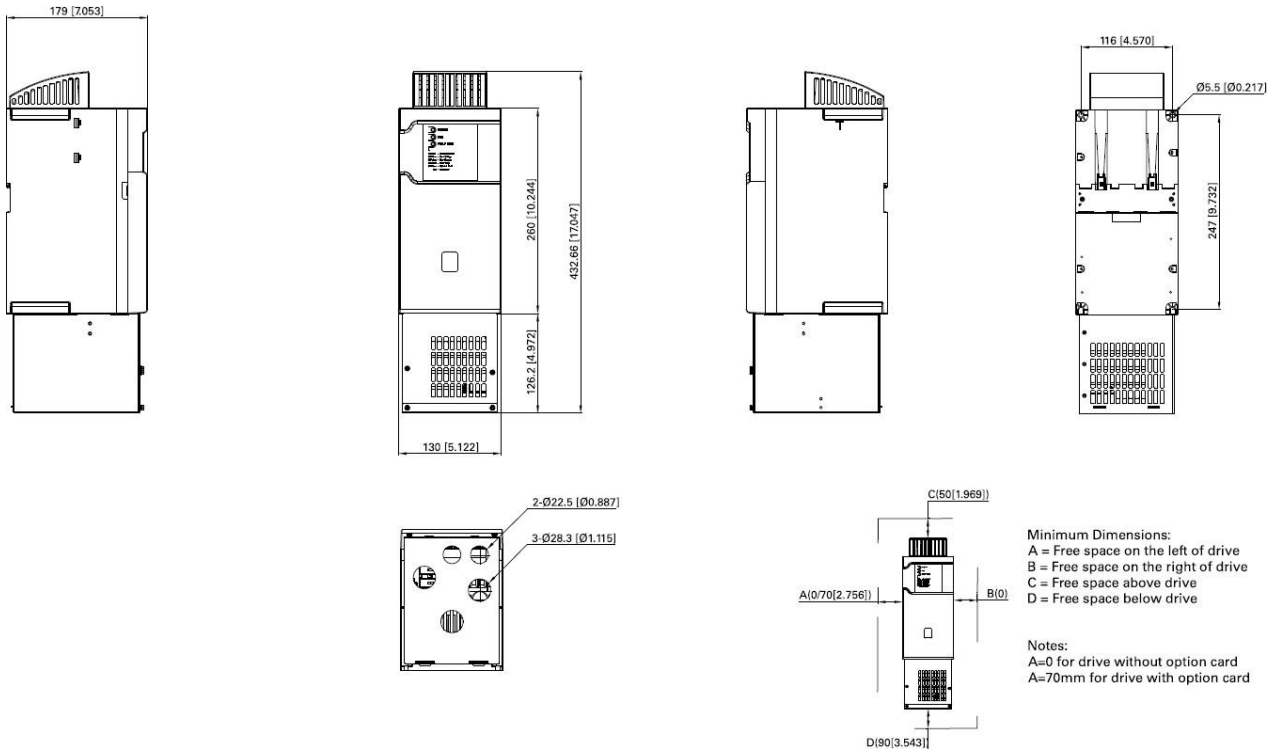

Appendix B Drive Dimensions

EVM-Pro FR4 with NEMA 1 kit Dimensions

Approximate dimensions in Inches (mm)

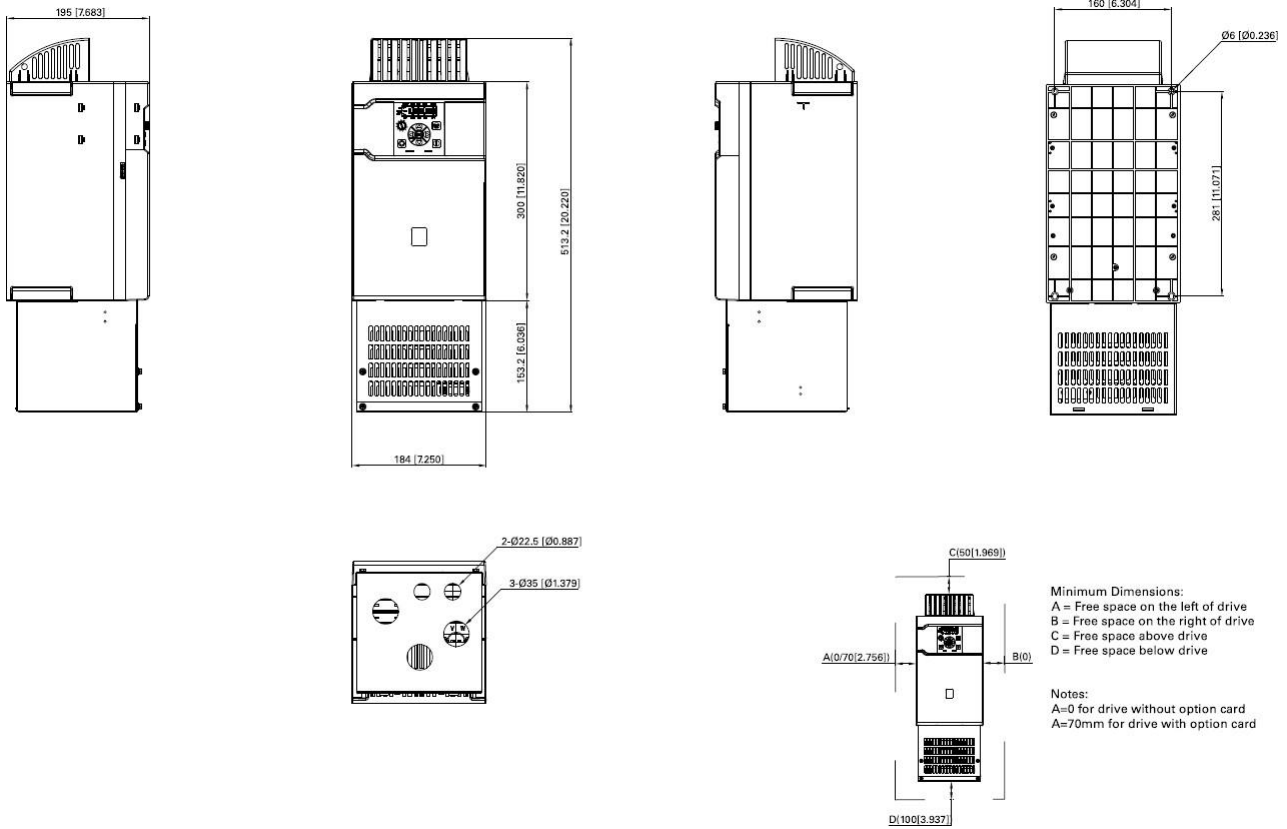

EVM FR4 with NEMA 1 kit Dimensions

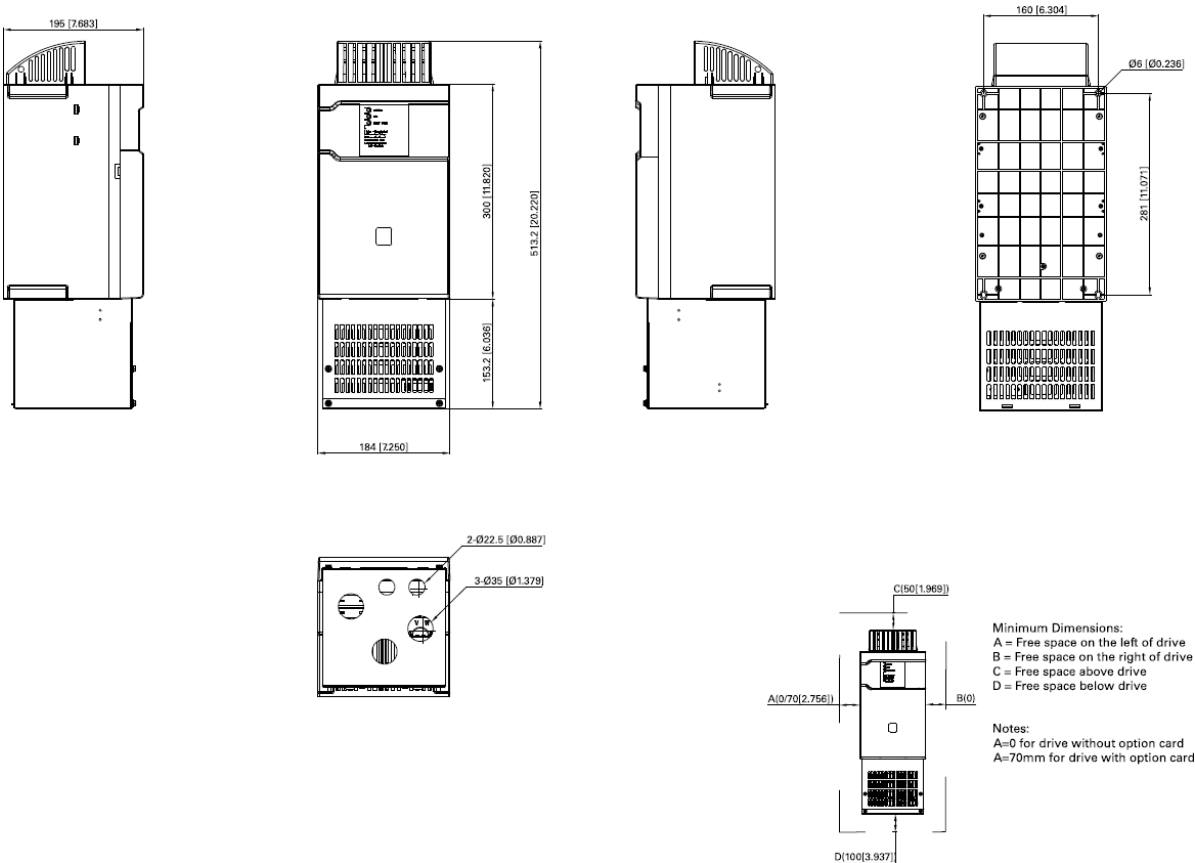

Parameters list

On the next pages you will find the lists of parameters within the respective parameter groups. Each parameter section within the table lists:

- Parameter code (location indication on the keypad; shows the operator the present parameter number);
- Parameter name;
- ID (number of the parameter);

and where applicable:

- Minimum value and units;
- Maximum value and units;
- Default value and units;
- Options (when available); and
- Description of the parameter.

Monit.or				
M1 - standard.				
M1.1	Output frequency			ID 1
Minimum value:	Hz	Maximum value:	Hz	Default value: Hz
Description:	Output frequency (Hz).			
M1.2	Frequency reference			ID 24
Minimum value:	Hz	Maximum value:	Hz	Default value: Hz
Description:	Reference frequency (Hz).			
M1.3	Motor speed			ID 2
Minimum value:	rpm	Maximum value:	rpm	Default value: rpm
Description:	Motor output speed (rpm).			
M1.4	Motor current			ID 3
Minimum value:	A	Maximum value:	A	Default value: A
Description:	Motor output current RMS (Amps).			
M1.5	Motor torque			ID 4
Minimum value:	%	Maximum value:	%	Default value: %
Description:	Percent motor torque calculated from nameplate values and measured motor current (%).			
M1.6	Motor power			ID 5
Minimum value:	%	Maximum value:	%	Default value: %
Description:	Percent motor power calculated from nameplate values and measured motor current (%).			
M1.7	Motor voltage			ID 6
Minimum value:	V	Maximum value:	V	Default value: V
Description:	Output ac motor voltage (Vac).			
M1.8	DC-link voltage			ID 7
Minimum value:	V	Maximum value:	V	Default value: V
Description:	DC bus voltage (Vdc).			
M1.9	Unit temperature			ID 8
Minimum value:	°C	Maximum value:	°C	Default value: °C
Description:	Heat sink temperature (deg C).			

Appendix C Parameter Descriptions

Monitor (Cont.).

M1 - standard (Cont.).					
M1.10	Motor temperature				ID 9
Minimum value:	%	Maximum value:	%	Default value:	%
Description:	Motor temperature value calculated from nameplate values and measured motor current (%).				
M1.11	Latest fault code				ID 28
Minimum value:	N.A.	Maximum value:	N.A.	Default value:	N.A.
Description:	Last active fault code value. See fault codes for the value shown here.				
M1.12	Instant motor power				ID 1686
Minimum value:	kW	Maximum value:	kW	Default value:	kW
Description:	Instantaneous motor power (kW).				
M2 - I/O status.					
M2.1	Analog input 1				ID 10
Minimum value:	Varies	Maximum value:	Varies	Default value:	Varies
Description:	Analog input 1 measured value (Vdc or Amps) selectable with dipswitch.				
M2.2	Keypad pot voltage				ID 1858
Minimum value:	V	Maximum value:	V	Default value:	V
Description:	Keypad potentiometer measured value (Vdc). EVM PRO only.				
M2.3	Analog output				ID 25
Minimum value:	Varies	Maximum value:	Varies	Default value:	Varies
Description:	Analog output 1 measured value (Vdc or Amps) selectable with parameter.				
M2.4	DI1, DI2, DI3				ID 12
Minimum value:	N.A.	Maximum value:	N.A.	Default value:	N.A.
Description:	Digital input 1/2/3 status.				
M2.5	DI4				ID 13
Minimum value:	N.A.	Maximum value:	N.A.	Default value:	N.A.
Description:	Digital input 4 status.				
M2.6	Virtual DI1, Virtual DI2				ID 1998
Minimum value:	N.A.	Maximum value:	N.A.	Default value:	N.A.
Description:	Virtual digital output status. Internal use, not external output. The virtual RO1 as virtual DI1 input. The virtual RO2 as virtual DI2 input.				
M2.7	Virtual RO1, Virtual RO2				ID 1817
Minimum value:	N.A.	Maximum value:	N.A.	Default value:	N.A.
Description:	Virtual relay output 1 and 2 status.				
M2.8	RO1, RO2				ID 557
Minimum value:	N.A.	Maximum value:	N.A.	Default value:	N.A.
Description:	Relay output 1 and 2 4 status.				
M3 - Energy savings					
M3.1[Ⓜ]	Energy savings				ID 2120
Minimum value:	Varies	Maximum value:	Varies	Default value:	0.000 varies
Description:	Displays the energy savings of the drive compared to linear V/f curve.				

Appendix C Parameter Descriptions

Monitor (Cont.).

M3.2^②	CO2 savings			ID 1818
Minimum value:	mt/y	Maximum value:	mt/y	Default value: 0.000 mt/y
Description:	Displays the CO2 savings of the drive compared to linear V/f curve.			
M4 - FB monitor menu.				
M4.1	Control board DIDO status			ID 2209
Minimum value:	N.A.	Maximum value:	N.A.	Default value: N.A.
Options:	Bit 0 = DI1_Status; Bit 1 = DI2_Status; Bit 2 = DI3_Status; Bit 3 = DI4_Status; Bit 4 = RO1_Status; Bit 5 = RO2_Status; Bit 6 = SlotA with board; Bit 7 = Virtual_RO1_Status; or Bit 8 = Virtual_RO2_Status.			
Description:	Control board digital input and relay output status provides the status of inputs and outputs on the control board.			
M4.2	Application status word			ID 29
Minimum value:	N.A.	Maximum value:	N.A.	Default value: N.A.
Options:	Bit 0 = MC_Ready; Bit 1 = MC_Run; Bit 2 = MC_Fault or Fault Trip; Bit 3 = FB_Ref_Active; Bit 4 = MC_Stopping; Bit 5 = MC_Reverse; Bit 6 = MC_Warning or AR-Fault; Bit 7 = MC_ZeroSpeed; Bit 8 = IO control indicator; Bit 9 = Panel control indicator; Bit 10 = Panel fieldbus control indicator; Bit 11 = MC_DC_Brake; Bit 12 = Run enable; Bit 13 = Run bypass; Bit 14 = External brake control; or Bit 15 = In bypass mode.			
Description:	Application status word will provide additional status indication of the health of the drive.			
M4.3	Standard status word			ID 2414
Minimum value:	N.A.	Maximum value:	N.A.	Default value: N.A.
Options:	Bit 0 = See STD status word B0 Sel (default = ready); Bit 1 = See STD status word B1 Sel (default = run); Bit 2 = See STD status word B2 Sel (default = fault); Bit 3 = See STD status word B3 Sel (default = fault Invert); Bit 4 = See STD status word B4 Sel (default = warning); Bit 5 = See STD status word B5 Sel (default = reversed); Bit 6 = See STD status word B6 Sel (default = at speed); Bit 7 = See STD status word B7 Sel (default = zero frequency); or Bit 8 - 15 = Not used.			
Description:	Standard status word is defined based of the parameter setting in the fieldbus process data group, define the first 8 bits of this status word. The options for these bits are based off the standard relay functions.			
M4.4	FB PI setpoint 1			ID 2542
Minimum value:	Varies	Maximum value:	PID1_ProcessUnit Max	Default value: Varies.
Description:	PID setpoint 1 value from fieldbus.			
M4.5	FB PI setpoint 2			ID 2544
Minimum value:	PID1_ProcessUnitMin	Maximum value:	PID1_ProcessUnit Max	Default value: Varies.
Description:	PID setpoint 2 value from fieldbus.			

Appendix C Parameter Descriptions

Monitor (Cont.).

M4.6	FB PI feedback				ID 2550
Minimum value:	% varies	Maximum value:	% varies	Default value:	% varies.
Description:	PID feedback 1 value from fieldbus.				
M5 - PI monitor.					
M5.1	PI set point				ID 16
Minimum value:	Varies	Maximum value:	Varies	Default value:	Varies
Description:	PI set point in process units.				
M5.2	PI feedback				ID 18
Minimum value:	Varies	Maximum value:	Varies	Default value:	Varies
Description:	PI feedback level in process units.				
M5.3	PI error value				ID 20
Minimum value:	Varies	Maximum value:	Varies	Default value:	Varies
Description:	PI error in process units.				
M5.4	PI output				ID 22
Minimum value:	%	Maximum value:	%	Default value:	%
Description:	PI output.				
M5.5	PI status				ID 23
Minimum value:	N.A.	Maximum value:	N.A.	Default value:	N.A.
Options:	0 = Stopped; 1 = Running; or 2 = Sleep mode.				
Description:	PI status indication, indicates if drive is stopped, running in PI mode, or in PI sleep mode.				
M6 - User defined scale.					
M6.1	Output				ID 2445
Minimum value:	Varies	Maximum value:	Varies	Default value:	Varies
Description:	User defined output value that can be configured with the users desired unit and scale.				
M6.2	Reference				ID 2447
Minimum value:	Varies	Maximum value:	Varies	Default value:	Varies
Description:	User defined reference value that can be configured with the users desired unit and scale.				
Multi-pump status (Cont.).					
M7.1 - Operation mode.					
M7.1.1	Drive 1				ID 2218
Minimum value:	N.A.	Maximum value:	N.A.	Default value:	N.A.
Options:	0 = Offline; 1 = Slave drive; 2 = Master drive; or 3 = Redundant drive.				
Description:	Provides the operating mode of drive 1 while using multi-pump mode.				

Appendix C Parameter Descriptions

Multi-pump status (Cont.).

M7.1.2	Drive 2				ID 2230
Minimum value:	N.A.	Maximum value:	N.A.	Default value:	N.A.
Options:	0 = Offline; 1 = Slave drive; 2 = Master drive; or 3 = Redundant drive.				
Description:	Provides the operating mode of drive 2 while using multi-pump mode.				
M7.1.3	Drive 3				ID 2242
Minimum value:	N.A.	Maximum value:	N.A.	Default value:	N.A.
Options:	0 = Offline; 1 = Slave drive; 2 = Master drive; or 3 = Redundant drive.				
Description:	Provides the operating mode of drive 3 while using multi-pump mode.				
M7.1.4	Drive 4				ID 2254
Minimum value:	N.A.	Maximum value:	N.A.	Default value:	N.A.
Options:	0 = Offline; 1 = Slave drive; 2 = Master drive; or 3 = Redundant drive.				
Description:	Provides the operating mode of drive 4 while using multi-pump mode.				
M7.1.5	Drive 5				ID 2266
Minimum value:	N.A.	Maximum value:	N.A.	Default value:	N.A.
Options:	0 = Offline; 1 = Slave drive; 2 = Master drive; or 3 = Redundant drive.				
Description:	Provides the operating mode of drive 5 while using multi-pump mode.				
M7.2 - Multi-pump status.					
M7.2.1	Drive 1				ID 2219
Minimum value:	N.A.	Maximum value:	N.A.	Default value:	5
Options:	0 = Stopped; 1 = Sleep; 2 = Regulating; 3 = Wait for CMD 4 = Following; or 5 = Unknown.				
Description:	Provides the run status of drive 1 while using the multi-pump mode.				
M7.2.2	Drive 2				ID 2231
Minimum value:	N.A.	Maximum value:	N.A.	Default value:	5
Options:	0 = Stopped; 1 = Sleep; 2 = Regulating; 3 = Wait for CMD 4 = Following; or 5 = Unknown.				
Description:	Provides the run status of drive 2 while using the multi-pump mode.				

Appendix C Parameter Descriptions

Multi-pump status (Cont.).

M7.2.3	Drive 3				ID 2243
Minimum value:	N.A.	Maximum value:	N.A.	Default value:	5
Options:	0 = Stopped; 1 = Sleep; 2 = Regulating; 3 = Wait for CMD 4 = Following; or 5 = Unknown.				
Description:	Provides the run status of drive 3 while using the multi-pump mode.				
M7.2.4	Drive 4				ID 2255
Minimum value:	N.A.	Maximum value:	N.A.	Default value:	5
Options:	0 = Stopped; 1 = Sleep; 2 = Regulating; 3 = Wait for CMD 4 = Following; or 5 = Unknown.				
Description:	Provides the run status of drive 4 while using the multi-pump mode.				
M7.2.5	Drive 5				ID 2267
Minimum value:	N.A.	Maximum value:	N.A.	Default value:	5
Options:	0 = Stopped; 1 = Sleep; 2 = Regulating; 3 = Wait for CMD 4 = Following; or 5 = Unknown.				
Description:	Provides the run status of drive 5 while using the multi-pump mode.				
M7.3 - Network status.					
M7.3.1	Drive 1				ID 2220
Minimum value:	N.A.	Maximum value:	N.A.	Default value:	N.A.
Options:	0 = Disconnected; 1 = Fault; 2 = Pump lost; 3 = Need alternation; or 4 = No error.				
Description:	Provides the network status of drive 1 while using the multi-pump mode.				
M7.3.2	Drive 2				ID 2232
Minimum value:	N.A.	Maximum value:	N.A.	Default value:	N.A.
Options:	0 = Disconnected; 1 = Fault; 2 = Pump lost; 3 = Need alternation; or 4 = No error.				
Description:	Provides the network status of drive 2 while using the multi-pump mode.				
M7.3.3	Drive 3				ID 2244
Minimum value:	N.A.	Maximum value:	N.A.	Default value:	N.A.
Options:	0 = Disconnected; 1 = Fault; 2 = Pump lost; 3 = Need alternation; or 4 = No error.				
Description:	Provides the network status of drive 3 while using the multi-pump mode.				

Appendix C Parameter Descriptions

Multi-pump status (Cont.).

M7.3.4	Drive 4				ID 2256
Minimum value:	N.A.	Maximum value:	N.A.	Default value:	N.A.
Options:	0 = Disconnected; 1 = Fault; 2 = Pump lost; 3 = Need alternation; or 4 = No error.				
Description:	Provides the network status of drive 4 while using the multi-pump mode.				
M7.3.5	Drive 5				ID 2268
Minimum value:	N.A.	Maximum value:	N.A.	Default value:	N.A.
Options:	0 = Disconnected; 1 = Fault; 2 = Pump lost; 3 = Need alternation; or 4 = No error.				
Description:	Provides the network status of drive 5 while using the multi-pump mode.				

Multi-pump measurement.(Cont.).

M8.1 - Latest fault code.

M8.1.1	Drive 1				ID 2221
Minimum value:		Maximum value:		Default value:	
Description:	Provides the latest fault code of drive 1 while using the multi-pump mode.				
M8.1.2	Drive 2				ID 2233
Minimum value:		Maximum value:		Default value:	
Description:	Provides the latest fault code of drive 2 while using the multi-pump mode.				
M8.1.3	Drive 3				ID 2245
Minimum value:		Maximum value:		Default value:	
Description:	Provides the latest fault code of drive 3 while using the multi-pump mode.				
M8.1.4	Drive 4				ID 2257
Minimum value:		Maximum value:		Default value:	
Description:	Provides the latest fault code of drive 4 while using the multi-pump mode.				
M8.1.5	Drive 5				ID 2269
Minimum value:		Maximum value:		Default value:	
Description:	Provides the latest fault code of drive 5 while using the multi-pump mode.				

M8.2 - Output frequency.

M8.2.1	Drive 1				ID 2222
Minimum value:	Hz	Maximum value:	Hz	Default value:	Hz
Description:	Provides the output frequency (Hz) of drive 1 while using the multi-pump mode.				
M8.2.2	Drive 2				ID 2234
Minimum value:	Hz	Maximum value:	Hz	Default value:	Hz
Description:	Provides the output frequency (Hz) of drive 2 while using the multi-pump mode.				
M8.2.3	Drive 3				ID 2246
Minimum value:	Hz	Maximum value:	Hz	Default value:	Hz
Description:	Provides the output frequency (Hz) of drive 3 while using the multi-pump mode.				

Appendix C Parameter Descriptions

Multi-pump measurement (Cont.).

M8.2.4	Drive 4			ID 2258
Minimum value:	Hz	Maximum value:	Hz	Default value: Hz
Description:	Provides the output frequency (Hz) of drive 4 while using the multi-pump mode.			
M8.2.5	Drive 5			ID 2270
Minimum value:	Hz	Maximum value:	Hz	Default value: Hz
Description:	Provides the output frequency (Hz) of drive 5 while using the multi-pump mode.			
M8.3 - Motor voltage.				
M8.3.1	Drive 1			ID 2223
Minimum value:	V	Maximum value:	V	Default value: V
Description:	Provides the motor voltage (Vac) of drive 1 while using the multi-pump mode.			
M8.3.2	Drive 2			ID 2235
Minimum value:	V	Maximum value:	V	Default value: V
Description:	Provides the motor voltage (Vac) of drive 2 while using the multi-pump mode.			
M8.3.3	Drive 3			ID 2247
Minimum value:	V	Maximum value:	V	Default value: V
Description:	Provides the motor voltage (Vac) of drive 3 while using the multi-pump mode.			
M8.3.4	Drive 4			ID 2259
Minimum value:	V	Maximum value:	V	Default value: V
Description:	Provides the motor voltage (Vac) of drive 4 while using the multi-pump mode.			
M8.3.5	Drive 5			ID 2271
Minimum value:	V	Maximum value:	V	Default value: V
Description:	Provides the motor voltage (Vac) of drive 5 while using the multi-pump mode.			
M8.4 - Motor current.				
M8.4.1	Drive 1			ID 2224
Minimum value:	A	Maximum value:	A	Default value: A
Description:	Provides the motor current (Amps) of drive 1 while using the multi-pump mode.			
M8.4.2	Drive 2			ID 2236
Minimum value:	A	Maximum value:	A	Default value: A
Description:	Provides the motor current (Amps) of drive 2 while using the multi-pump mode.			
M8.4.3	Drive 3			ID 2248
Minimum value:	A	Maximum value:	A	Default value: A
Description:	Provides the motor current (Amps) of drive 3 while using the multi-pump mode.			
M8.4.4	Drive 4			ID 2260
Minimum value:	A	Maximum value:	A	Default value: A
Description:	Provides the motor current (Amps) of drive 4 while using the multi-pump mode.			
M8.4.5	Drive 5			ID 2272
Minimum value:	A	Maximum value:	A	Default value: A
Description:	Provides the motor current (Amps) of drive 5 while using the multi-pump mode.			

Appendix C Parameter Descriptions

Multi-pump measurement (Cont.)

M8.5 - Motor torque.					
M8.5.1	Drive 1				ID 2225
Minimum value:	%	Maximum value:	%	Default value:	%
Description:	Provides the motor torque (%) of drive 1 while using the multi-pump mode.				
M8.5.2	Drive 2				ID 2237
Minimum value:	%	Maximum value:	%	Default value:	%
Description:	Provides the motor torque (%) of drive 2 while using the multi-pump mode.				
M8.5.3	Drive 3				ID 2249
Minimum value:	%	Maximum value:	%	Default value:	%
Description:	Provides the motor torque (%) of drive 3 while using the multi-pump mode.				
M8.5.4	Drive 4				ID 2261
Minimum value:	%	Maximum value:	%	Default value:	%
Description:	Provides the motor torque (%) of drive 4 while using the multi-pump mode.				
M8.5.5	Drive 5				ID 2273
Minimum value:	%	Maximum value:	%	Default value:	%
Description:	Provides the motor torque (%) of drive 5 while using the multi-pump mode.				
M8.6 - Motor power.					
M8.6.1	Drive 1				ID 2226
Minimum value:	%	Maximum value:	%	Default value:	%
Description:	Provides the motor power (%) of drive 1 while using the multi-pump mode.				
M8.6.2	Drive 2				ID 2238
Minimum value:	%	Maximum value:	%	Default value:	%
Description:	Provides the motor power (%) of drive 2 while using the multi-pump mode.				
M8.6.3	Drive 3				ID 2250
Minimum value:	%	Maximum value:	%	Default value:	%
Description:	Provides the motor power (%) of drive 3 while using the multi-pump mode.				
M8.6.4	Drive 4				ID 2262
Minimum value:	%	Maximum value:	%	Default value:	%
Description:	Provides the motor power (%) of drive 4 while using the multi-pump mode.				
M8.6.5	Drive 5				ID 2274
Minimum value:	%	Maximum value:	%	Default value:	%
Description:	Provides the motor power (%) of drive 5 while using the multi-pump mode.				
M8.7 - Motor speed.					
M8.7.1	Drive 1				ID 2227
Minimum value:	rpm	Maximum value:	rpm	Default value:	rpm
Description:	Provides the motor speed (rpm) of drive 1 while using the multi-pump mode.				
M8.7.2	Drive 2				ID 2239
Minimum value:	rpm	Maximum value:	rpm	Default value:	rpm
Description:	Provides the motor speed (rpm) of drive 2 while using the multi-pump mode.				
M8.7.3	Drive 3				ID 2251
Minimum value:	rpm	Maximum value:	rpm	Default value:	rpm
Description:	Provides the motor speed (rpm) of drive 3 while using the multi-pump mode.				

Appendix C Parameter Descriptions

Multi-pump measurement (Cont.).

M8.7.4	Drive 4			ID 2263
Minimum value:	rpm	Maximum value:	rpm	Default value: rpm
Description:	Provides the motor speed (rpm) of drive 4 while using the multi-pump mode.			
M8.7.5	Drive 5			ID 2275
Minimum value:	rpm	Maximum value:	rpm	Default value: rpm
Description:	Provides the motor speed (rpm) of drive 5 while using the multi-pump mode.			
M8.8 - Run time.				
M8.8.1	Drive 1			ID 2228
Minimum value:	Hours	Maximum value:	Hours	Default value: Hours
Description:	Provides the motor run time (h) of drive 1 while using the multi-pump mode.			
M8.8.2	Drive 2			ID 2240
Minimum value:	Hours	Maximum value:	Hours	Default value: Hours
Description:	Provides the motor run time (h) of drive 2 while using the multi-pump mode.			
M8.8.3	Drive 3			ID 2252
Minimum value:	Hours	Maximum value:	Hours	Default value: Hours
Description:	Provides the motor run time (h) of drive 3 while using the multi-pump mode.			
M8.8.4	Drive 4			ID 2264
Minimum value:	Hours	Maximum value:	Hours	Default value: Hours
Description:	Provides the motor run time (h) of drive 4 while using the multi-pump mode.			
M8.8.5	Drive 5			ID 2276
Minimum value:	Hours	Maximum value:	Hours	Default value: Hours
Description:	Provides the motor run time (h) of drive 5 while using the multi-pump mode.			
M9 - Multi-monitoring.				
M9.1	Multi-monitoring			ID 30
Minimum value:	N.A.	Maximum value:	N.A.	Default value: 0, 1, 2.
Description:	Displays any three monitoring values in a single screen. The values are selectable via the keypad menu. Multi-monitor page could see three lines of monitoring values. Up and down keys can be used to select the row and then hitting the left arrow key will allow for editing the value then by going up and down.			

Parameters

P1 - Basic parameters.				
P1.1^②	Minimum frequency			ID 101
Minimum value:	0.00 Hz	Maximum value:	400.00 Hz	Default value: 0.00 Hz
Description:	Defines the lowest frequency at which the drive will operate. This setting will limit other frequency parameter settings. 1 = Fire mode minimum frequency. 2 = Derag. 3 = MPFC staging frequency. 4 = MPFC master fixed frequency. 5 = Prime pump frequency. 6 = Prime pump frequency 2.			

Appendix C Parameter Descriptions

Parameters (Cont.).

P1.2^②	Maximum frequency			ID 102
Minimum value:	0.00 Hz	Maximum value:	400.00 Hz	Default value: MaxFreqMFG
Description:	Defines the highest frequency at which the drive will operate. This will limit other frequency parameters. 1 = Keypad reference. 2 = Motor potentiometer. 3 = Jog speed. 4 = 2nd stage ramp frequency. 5 = Fire mode minimum frequency. 6 = Derag. 7 = MPFC staging frequency. 8 = MPFC master fixed frequency. 9 = Prime pump frequency. 10 = Prime pump frequency 2. 11 = Preset speed frequency. 12 = Frequency limit value. 13 = Reference limit value. 14 = Speed control_fs2. 15 = Stall frequency limit. 16 = 4 mA fault frequency. 17 = MPFC de-staging frequency. 18 = Pipe fill loss frequency low. 19 = Pipe fill loss frequency high. 20 = Broken pipe frequency limit.			
P1.3^②	Accel. time 1			ID 103
Minimum value:	0.1 s	Maximum value:	3,000.0 s	Default value: 20.0 s
Description:	Defines the time required for the output frequency to accelerate from zero frequency to maximum frequency.			
P1.4^②	Decel. time 1			ID 104
Minimum value:	0.1 s	Maximum value:	3,000.0 s	Default value: 20.0 s
Description:	Defines the time required for the output frequency to decelerate from maximum frequency to zero frequency.			
P1.5^②	Motor type selection			ID 1820
Minimum value:	N.A.	Maximum value:	N.A.	Default value: 0
Options:	0 = Inverter duty; 1 = IPM; or 2 = SPM.			
Description:	Defines the type of motor connected to the drive: standard induction motor, internally mounted permanent magnet, or surface mount permanent magnet.			
P1.6^①	Motor nom. current			ID 486
Minimum value:	DriveNomCurrCT*1/10 A	Maximum value:	DriveNomCurrCT*2 A	Default value: DriveNomCurrCT A
Description:	Motor nameplate rated full load current. This value is found on the rating plate of the motor.			
Motor parameters from ratings plate				
<div style="border: 1px solid black; padding: 5px; width: fit-content;"> <p>Note: Parameter information can be accessed on nameplate of induction motors. Please reach out to an application engineer to obtain parameter information of permanent magnetic motors.</p> </div>				
P1.7^①	Motor nom. speed			ID 489
Minimum value:	300 rpm	Maximum value:	20,000 rpm	Default value: MotorNomSpeedMFG
Description:	Motor nameplate rated speed. This value is found on the rating plate of the motor.			

Appendix C Parameter Descriptions

Parameters (Cont.).

P1.8^①	Motor PF			ID 490
Minimum value:	0.30	Maximum value:	1.00	Default value: 0.85
Description:	Motor nameplate rated power factor. This value is found on the rating plate of the motor.			
P1.9^①	Motor nom. voltage			ID 487
Minimum value:	180 V	Maximum value:	690 V	Default value: MotorNomVoltMFG V
Description:	Motor nameplate rated voltage. This value is found on the rating plate of the motor.			
P1.10^①	Motor nom. frequency			ID 488
Minimum value:	8.00 Hz	Maximum value:	400.00 Hz	Default value: MotorNomFreqMFG Hz
Description:	Motor nameplate rated frequency. This value is found on the rating plate of the motor.			
P1.11^②	Local control place			ID 1695
Minimum value:	N.A.	Maximum value:	N.A.	Default value: 0
Options:	0 = keypad; 1 = I/O terminal; or 3 = fieldbus.			
Description:	Defines the signal location for the start command in local mode. I/O terminals would be from the digital hard-wired inputs or keypad for Start/Stop buttons on the drive. Keypad display will indicate which mode is selected.			
P1.12^{①②}	Local reference			ID 136
Minimum value:	N.A.	Maximum value:	N.A.	Default value: 1
Options:	0 = AI; 1 = Drive reference pot; 2 = AI joystick; 3 = Motor pot; 4 = Maximum frequency; 5 = PI control output; 6 = Keypad; or 7 = Fieldbus reference.			
Description:	Defines the signal location for the speed reference in local mode.			
P1.13^②	Remote control place			ID 135
Minimum value:	N.A.	Maximum value:	N.A.	Default value: 0
Options:	0 = I/O terminal; 1 = fieldbus; or 3 = keypad.			
Description:	Defines the signal location for the start command in remote mode. I/O terminals would be from the digital hard-wired inputs or keypad for Start/Stop buttons on the drive. Keypad display will indicate which mode is selected.			
P1.14^{①②}	Remote reference			ID 137
Minimum value:	N.A.	Maximum value:	N.A.	Default value: 0
Options:	0 = AI; 1 = Drive reference pot; 2 = AI joystick; 3 = Motor pot; 4 = Maximum frequency; 5 = PI control output; 6 = Keypad; or 7 = Fieldbus reference.			
Description:	Defines the signal location for the speed reference in remote mode.			

Inputs

P2.1 - Basic settings.				
P2.1.1^②	AI reference scale minimum value			ID 144
Minimum value:	0.00 Hz	Maximum value:	MaxFreq Hz	Default value: 0.00 Hz
Description:	Defines the minimum frequency associated with 0% input from the analog input. Setting AI ref scale minimum value and AI reference scale maximum value both to zero will cause the analog input to scale to the minimum and maximum frequencies.			

Inputs (Cont.).

P2.1.2 ^②	AI reference scale maximum value			ID 145
Minimum value:	RefScaleMin Hz	Maximum value:	400.00 Hz	Default value: 0.00 Hz
Description:	Defines the maximum frequency associated with 100% input from the analog input. Setting AI reference scale minimum value and AI reference scale maximum value both to zero will cause the analog input to scale to the minimum and maximum frequencies.			

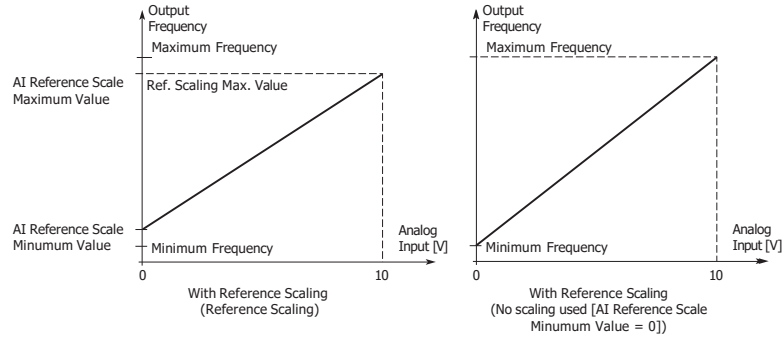

P2.1.3 ^{①②}	IO terminal Start/Stop logic			ID 143
Minimum value:	N.A.	Maximum value:	N.A.	Default value: 0

Options:
 0 = Forward - reverse: maintained input on start signal 1 to run forward and a maintained signal on start signal 2 for reverse.
 1 = Start - reverse: maintained input on start signal 1 to run forward and a maintained signal on start signal 2 for reverse.
 2 = Start - enable: maintained input on start signal 1 to run forward and a maintained signal on start signal 2 to enable the drive to run.
 3 = Start pulse - stop pulse: used for three-wire operation, start signal 1 uses a normally open start and start signal 2 uses a normally closed stop.

Description:
 Defines the functionality for start signal 1 and start signal 2. By default, start signal 1 is DI1 and start signal 2 is DI2.
 0 = P3.2: IO terminal start signal 1 = start forward - P3.3: IO terminal start signal 2 = start reverse. This would be considered 2-wire control with either a contact used on the start FWD or start REV commands. When contacts open, the motor stops.

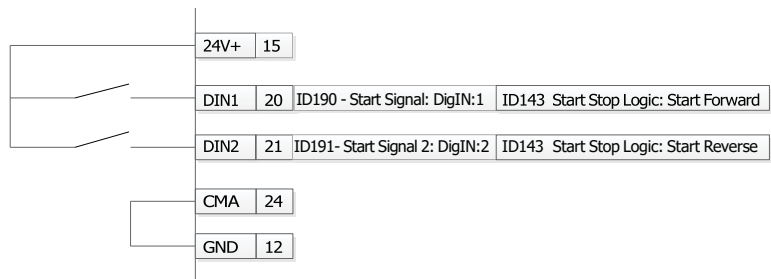

Inputs (Cont.)

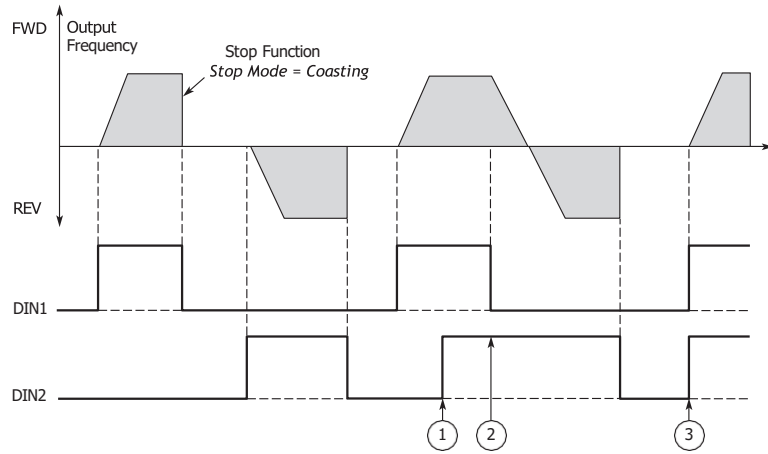

- Notes:
- ① The first selected direction has the highest priority.
 - ② When the DIN1 contact opens the direction of rotation starts to change.
 - ③ If start forward (DIN1) and start reverse (DIN2) signals are active simultaneously the start forward signal (DIN1) has priority.

1 = P3.2: IO terminal start signal 1 = start forward - P3.3: IO terminal start signal 2 = start reverse. This would be considered 2-wire control with a contact on start/stop, contact open it stops and direction on 2nd start signal.

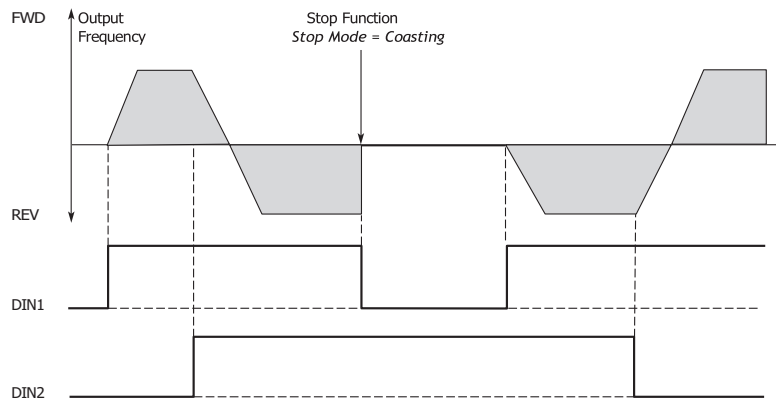
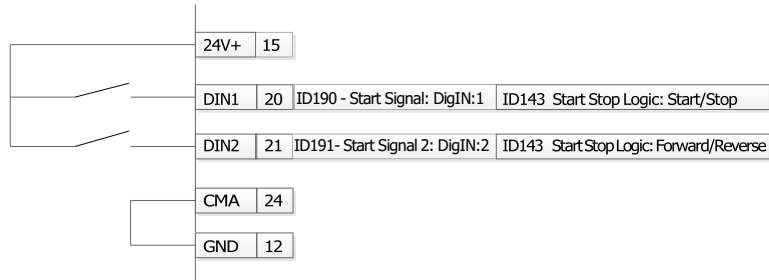

Inputs (Cont.).

2 = P3.2: IO terminal start signal 1 = start forward - P3.3: IO terminal start signal 2 = start reverse. This would be considered 3-wire control with start signal 2 required to be closed to enable start on start signal 1.

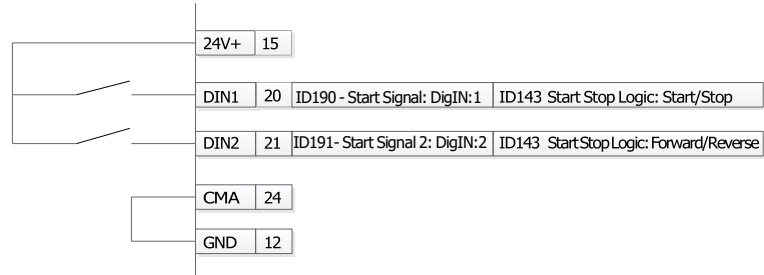

3 = Three-wire connection (pulse control): P3.2: IO terminal start signal 1 = start forward - P3.3: IO terminal start signal 2 = start reverse. This would be considered 3-wire control with start signal 1 being the start pulse and start signal 2 being the NC stop.

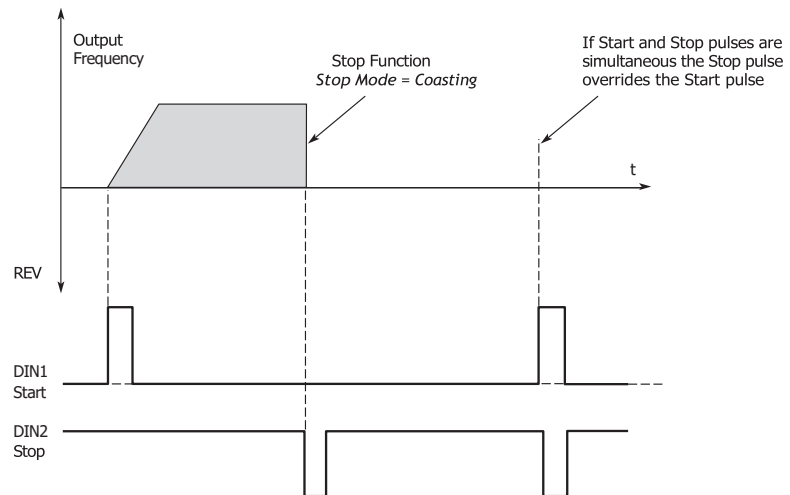
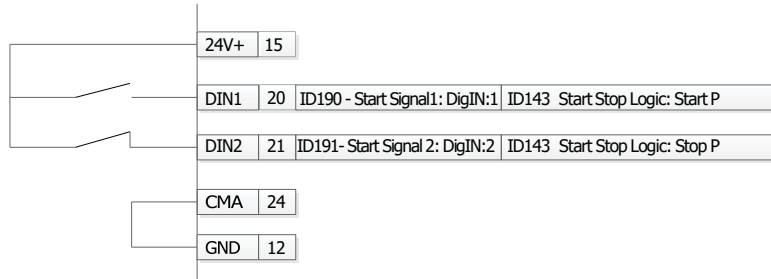

Appendix C Parameter Descriptions

Inputs (Cont.).

P2.1.4^②	External fault 1 text				ID 2297
Minimum value:	N.A.	Maximum value:	N.A.	Default value:	0
Options:	0 = External fault; 1 = Vibration cutout; 2 = High motor temperature; 3 = Low pressure; 4 = High pressure; 5 = Low water; 6 = Damper interlock; 7 = Run enable; 8 = Freeze stat trip; 9 = Smoke detect; 10 = Seal leakage; 11 = Rod breakage; or 12 = Belt break.				
Description:	Defines the text to be displayed when external fault 1 NO or NC is triggered. This text will be viewable using a remote keypad, or the built in web server.				
P2.1.5^②	External fault 2 text				ID 2298
Minimum value:	N.A.	Maximum value:	N.A.	Default value:	1
Options:	0 = External fault; 1 = Vibration cutout; 2 = High motor temperature; 3 = Low pressure; 4 = High pressure; 5 = Low water; 6 = Damper interlock; 7 = Run enable; 8 = Freeze stat trip; 9 = Smoke detect; 10 = Seal leakage; 11 = Rod breakage; or 12 = Belt break.				
Description:	Defines the text to be displayed when external fault 2 NO or NC is triggered. This text will be viewable using a remote keypad, or the built in webserver.				
P2.1.6^②	External fault 3 text				ID 2299
Minimum value:	N.A.	Maximum value:	N.A.	Default value:	2
Options:	0 = External fault; 1 = Vibration cutout; 2 = High motor temperature; 3 = Low pressure; 4 = High pressure; 5 = Low water; 6 = Damper interlock; 7 = Run enable; 8 = Freeze stat trip; 9 = Smoke detect; 10 = Seal leakage; 11 = Rod breakage; or 12 = Belt break.				
Description:	Defines the text to be displayed when external fault 3 NO or NC is triggered. This text will be viewable using a remote keypad, or the built in webserver.				
P2.1.7^②	Motor pot ramp time				ID 156
Minimum value:	0.1 Hz/s	Maximum value:	2,000.0 Hz/s	Default value:	10.0 Hz/s
Description:	Defines the speed of change for the motor potentiometer reference value.				
P2.1.8^②	Motor pot reference reset				ID 169
Minimum value:	N.A.	Maximum value:	N.A.	Default value:	0
Options:	0 = No reset - reference stays at last setting; 1 = Memory reset in stop and power down - reference resets to 0 when drive is stopped or the power is cycled to the drive; or 2 = Memory reset in power down - reference resets to 0 when drive is powered down only.				
Description:	Defines how the motor pot reference signal is handled on shutting down frequency converter output or powering down the frequency converter.				

Appendix C Parameter Descriptions

Inputs (Cont.)

P2.2 - Digital input.					
P2.2.1 ^②	DI1 function				ID 1801
Minimum value:	N.A.	Maximum value:	N.A.	Default value:	1
Options:	0 = Not used, no action. 1 = IO terminal start signal 1, when the control source is set to IO terminal, this input when closed will perform the action defined by P2.1.3. 2 = IO terminal start signal 2, when the control source is set to IO terminal, this input when closed will perform the action defined by P2.1.3. 3 = Reverse, when Start/Stop logic is set to 3 start pulse stop pulse, this input will cause the drive to start in the reverse direction. 4 = Ext. fault 1, when closed, Ext. fault 1 will be activated. 5 = Ext. fault 2, when closed, Ext. fault 2 will be activated. 6 = Ext. fault 3, when closed, Ext. fault 3 will be activated. 7 = Fault reset, when closed all active faults will be reset. 8 = Run enable, when closed, the drive will allow a start command and be in the ready state. 9 = Preset speed B0, the seven preset speeds are selected via three binary inputs. This is least significant bit in that binary input. 10 = Preset speed B1, the seven preset speeds are selected via three binary inputs. 11 = Preset speed B2, the seven preset speeds are selected via three binary inputs. This is most significant bit in that binary input. 12 = Jog enable, when closed, the jog speed defined at P2.3.8 will override the frequency reference. 13 = Accel. pot value, when closed, the motor potentiometer value will increment at the rate defined by motor pot ramp time. 14 = Decel. pot value, when closed, the motor potentiometer value will decrement at the rate defined by motor pot ramp time. 15 = Reset pot zero, when closed, the motor potentiometer value will reset to zero. 16 = Accel./Decel. time set, when open, Accel./Decel. time 1 will be used. When closed, Accel./Decel. time 2 will be used. 17 = Accel./Decel. prohibit, when closed, the drive will hold the output frequency and ignore changes to the reference value. 18 = No access to param., when closed, no changes can be made to any setting in the drive. 19 = Remote control, when closed, the drive will be forced to the remote control place. 20 = Local control, when closed, the drive will be forced to the local control place. 21 = Parameter 1/2 Sel., when open, parameter set 1 is active. When closed, parameter set 2 is active. 22 = PI controller, when closed, the drive will force the reference source to PI controller output. 23 = PI setpoint select, when open, parameter setpoint 1 is active. When closed setpoint 2 is active. 24 = Motor interlock 1, when closed, motor will be enabled to run. 25 = Smoke mode, when closed, smoke mode will be active. 26 = Fire mode, when closed, the fire mode will be active. 27 = Fire mode Ref. 1/2 select, when fire mode is active and this input is open, fire mode Ref. 1 will be active. When closed, fire mode Ref. 2 will be active. 28 = Fire mode reverse, when fire mode is active and this input is open, the direction will be forward. When closed, the direction will be reverse. 29 = DC brake active, when closed, DC injection braking will be active. 30 = Preheat active, when closed, the preheat mode will be active. 31 = Derag. enable, when closed, the Derag. cycle for pumps will be initiated.				
Description:	Defines the function of digital input 1.				
P2.2.2 ^②	DI1 invert				ID 1802
Minimum value:	N.A.	Maximum value:	N.A.	Default value:	0
Options:	0 = Disabled; or 1 = Enabled.				
Description:	When enabled, the function assigned to DI1 will be activated with the opposite state of DI1.				

Appendix C Parameter Descriptions

Inputs (Cont.).

P2.2.3^②	D12 function			ID 1803
Minimum value:	N.A.	Maximum value:	N.A.	Default value: 2
Options:	0 = Not used, no action. 1 = IO terminal start signal 1, when the control source is set to IO terminal, this input when closed will perform the action defined by P2.1.3. 2 = IO terminal start signal 2, when the control source is set to IO terminal, this input when closed will perform the action defined by P2.1.3. 3 = Reverse, when Start/Stop logic is set to three start pulse stop pulse, this input will cause the drive to start in the reverse direction. 4 = Ext. fault 1, when closed, Ext. fault 1 will be activated. 5 = Ext. fault 2, when closed, Ext. fault 2 will be activated. 6 = Ext. fault 3, when closed, Ext. fault 3 will be activated. 7 = Fault reset, when closed, all active faults will be reset. 8 = Run enable, when closed, the drive will allow a start command and be in the ready state. 9 = Preset speed B0, the seven preset speeds are selected via three binary inputs. This is least significant bit in that binary input. 10 = Preset speed B1, the seven preset speeds are selected via three binary inputs. 11 = Preset speed B2, the seven preset speeds are selected via three binary inputs. This is most significant bit in that binary input. 12 = Jog enable, when closed, the jog speed defined at P2.3.8 will override the frequency reference. 13 = Accel. pot value, when closed, the motor potentiometer value will increment at the rate defined by motor pot ramp time. 14 = Decel. pot value, when closed, the motor potentiometer value will decrement at the rate defined by motor pot ramp time. 15 = Reset pot zero, when closed, the motor potentiometer value will reset to zero. 16 = Accel./decel. time set, when open, accel./decel. time 1 will be used. When closed, accel./decel. time 2 will be used. 17 = Accel./decel. prohibit, when closed, the drive will hold the output frequency and ignore changes to the reference value. 18 = No access to param., when closed, no changes can be made to any setting in the drive. 19 = Remote control, when closed, the drive will be forced to the remote control place. 20 = Local control, when closed, the drive will be forced to the local control place. 21 = Parameter 1/2 Sel., when open, parameter set 1 is active. When closed, Parameter set 2 is active. 22 = PI controller, when closed, the drive will force the reference source to PI controller output. 23 = PI setpoint select, when open, parameter setpoint 1 is active. When closed, setpoint 2 is active. 24 = Motor interlock 1, when closed, the motor will be enabled to run. 25 = Smoke mode, when closed, smoke mode will be active. 26 = Fire mode, when closed, fire mode will be active. 27 = Fire mode Ref. 1/2 Sel., when fire mode is active and this input is open, fire mode Ref. 1 will be active. When closed, fire mode Ref. 2 will be active. 28 = Fire mode reverse, when fire mode is active and this input is open, the direction will be forward. When closed, the direction will be reverse. 29 = DC brake active, when closed, DC injection braking will be active. 30 = Preheat active, when closed, preheat mode will be active. 31 = Derag. enable, when closed, the Derag. cycle for pumps will be initiated.			
Description:	Defines the function of digital input 2.			
P2.2.4^②	D12 invert			ID 1804
Minimum value:	N.A.	Maximum value:	N.A.	Default value: 0
Options:	0 = Disable; or 1 = Enable.			
Description:	When enabled, the function assigned to D12 will be activated with the opposite state of D12.			

Appendix C Parameter Descriptions

Inputs (Cont.)

P2.2.5^②	D13 function			ID 1805
Minimum value:	N.A.	Maximum value:	N.A.	Default value: 4
Options:	0 = Not used, no action. 1 = IO terminal start signal 1, when the control source is set to IO terminal, this input when closed will perform the action defined by P2.1.3. 2 = IO terminal start signal 2, when the control source is set to IO terminal, this input when closed will perform the action defined by P2.1.3. 3 = Reverse, when Start/Stop logic is set to three start pulse stop pulse, this input will cause the drive to start in the reverse direction. 4 = Ext. fault 1, when closed, Ext. fault 1 will be activated. 5 = Ext. fault 2, when closed, Ext. fault 2 will be activated. 6 = Ext. fault 3, when closed, Ext. fault 3 will be activated. 7 = Fault reset, when closed, all active faults will be reset. 8 = Run enable, when closed, the drive will allow a start command and be in the ready state. 9 = Preset speed B0, the seven preset speeds are selected via three binary inputs. This is least significant bit in that binary input. 10 = Preset speed B1, the seven preset speeds are selected via three binary inputs. 11 = Preset speed B2, the seven preset speeds are selected via three binary inputs. This is most significant bit in that binary input. 12 = Jog enable, when closed, the jog speed defined at P2.3.8 will override the frequency reference. 13 = Accel. pot value, when closed, the motor potentiometer value will increment at the rate defined by motor pot ramp time. 14 = Decel. pot value, when closed, the motor potentiometer value will decrement at the rate defined by motor pot ramp time. 15 = Reset pot zero, when closed, the motor potentiometer value will reset to zero. 16 = Accel./decel. time set, when open, accel./decel. time 1 will be used. When closed, accel./decel. time 2 will be used. 17 = Accel./decel. prohibit, when closed, the drive will hold the output frequency and ignore changes to the reference value. 18 = No access to param., when closed, no changes can be made to any setting in the drive. 19 = Remote control, when closed, the drive will be forced to the remote control place. 20 = Local control, when closed, the drive will be forced to the local control place. 21 = Parameter 1/2 Sel., when open, parameter set 1 is active. When closed, Parameter set 2 is active. 22 = PI controller, when closed, the drive will force the reference source to PI controller output. 23 = PI setpoint select, when open, parameter setpoint 1 is active. When closed, setpoint 2 is active. 24 = Motor interlock 1, when closed, the motor will be enabled to run. 25 = Smoke mode, when closed, smoke mode will be active. 26 = Fire mode, when closed, fire mode will be active. 27 = Fire mode Ref. 1/2 Sel., when fire mode is active and this input is open, fire mode Ref. 1 will be active. When closed, fire mode Ref. 2 will be active. 28 = Fire mode reverse, when fire mode is active and this input is open, the direction will be forward. When closed, the direction will be reverse. 29 = DC brake active, when closed, DC injection braking will be active. 30 = Preheat active, when closed, preheat mode will be active. 31 = Derag. enable, when closed, the Derag. cycle for pumps will be initiated.			
Description:	Defines the function of digital input 3.			
P2.2.6^②	D13 invert			ID 1806
Minimum value:	N.A.	Maximum value:	N.A.	Default value: 0
Options:	0 = Disable; or 1 = Enable.			
Description:	When enabled, the function assigned to D13 will be activated with the opposite state of D13.			

Appendix C Parameter Descriptions

Inputs (Cont.)

P2.2.7^②	DI4 function			ID 1807
Minimum value:	N.A.	Maximum value:	N.A.	Default value: 7
Options:	0 = Not used, no action. 1 = IO terminal start signal 1, when the control source is set to IO terminal, this input when closed will perform the action defined by P2.1.3. 2 = IO terminal start signal 3, when the control source is set to IO terminal, this input when closed will perform the action defined by P2.1.3. 3 = Reverse, when Start/Stop logic is set to three start pulse stop pulse, this input will cause the drive to start in the reverse direction. 4 = Ext. fault 1, when closed, Ext. fault 1 will be activated. 5 = Ext. fault 2, when closed, Ext. fault 2 will be activated. 6 = Ext. fault 3, when closed, Ext. fault 3 will be activated. 7 = Fault reset, when closed, all active faults will be reset. 8 = Run enable, when closed, the drive will allow a start command and be in the ready state. 9 = Preset speed B0, the seven preset speeds are selected via three binary inputs. This is least significant bit in that binary input. 10 = Preset speed B1, the seven preset speeds are selected via three binary inputs. 11 = Preset speed B2, the seven preset speeds are selected via three binary inputs. This is most significant bit in that binary input. 12 = Jog enable, when closed, the jog speed defined at P2.3.8 will override the frequency reference. 13 = Accel. pot value, when closed, the motor potentiometer value will increment at the rate defined by motor pot ramp time. 14 = Decel. pot value, when closed, the motor potentiometer value will decrement at the rate defined by motor pot ramp time. 15 = Reset pot zero, when closed, the motor potentiometer value will reset to zero. 16 = Accel./decel. time set, when open, accel./decel. time 1 will be used. When closed, accel./decel. time 2 will be used. 17 = Accel./decel. prohibit, when closed, the drive will hold the output frequency and ignore changes to the reference value. 18 = No access to param., when closed, no changes can be made to any setting in the drive. 19 = Remote control, when closed, the drive will be forced to the remote control place. 20 = Local control, when closed, the drive will be forced to the local control place. 21 = Parameter 1/2 Sel., when open, parameter set 1 is active. When closed, Parameter set 2 is active. 22 = PI controller, when closed, the drive will force the reference source to PI controller output. 23 = PI setpoint select, when open, parameter setpoint 1 is active. When closed, setpoint 2 is active. 24 = Motor interlock 1, when closed, the motor will be enabled to run. 25 = Smoke mode, when closed, smoke mode will be active. 26 = Fire mode, when closed, fire mode will be active. 27 = Fire mode Ref. 1/2 Sel., when fire mode is active and this input is open, fire mode Ref. 1 will be active. When closed, fire mode Ref. 2 will be active. 28 = Fire mode reverse, when fire mode is active and this input is open, the direction will be forward. When closed, the direction will be reverse. 29 = DC brake active, when closed, DC injection braking will be active. 30 = Preheat active, when closed, preheat mode will be active. 31 = Derag. enable, when closed, the Derag. cycle for pumps will be initiated.			
Description:	Defines the function of digital input 4.			
P2.2.8^②	DI4 invert			ID 1808
Minimum value:	N.A.	Maximum value:	N.A.	Default value: 0
Options:	0 = Disable; or 1 = Enable.			
Description:	When enabled, the function assigned to DI4 will be activated with the opposite state of DI4.			

Appendix C Parameter Descriptions

Inputs (Cont.).

P2.2.9^②	Virtual RO1 input				ID 1809
Minimum value:	N.A.	Maximum value:	N.A.	Default value:	0
Options:	0 = Not used, no action. 1 = IO terminal start signal 1, when the control source is set to IO terminal, this input when closed will perform the action defined by P2.1.3. 2 = IO terminal start signal 3, when the control source is set to IO terminal, this input when closed will perform the action defined by P2.1.3. 3 = Reverse, when Start/Stop logic is set to three start pulse stop pulse, this input will cause the drive to start in the reverse direction. 4 = Ext. fault 1, when closed, Ext. fault 1 will be activated. 5 = Ext. fault 2, when closed, Ext. fault 2 will be activated. 6 = Ext. fault 3, when closed, Ext. fault 3 will be activated. 7 = Fault reset, when closed, all active faults will be reset. 8 = Run enable, when closed, the drive will allow a start command and be in the ready state. 9 = Preset speed B0, the seven preset speeds are selected via three binary inputs. This is least significant bit in that binary input. 10 = Preset speed B1, the seven preset speeds are selected via three binary inputs. 11 = Preset speed B2, the seven preset speeds are selected via three binary inputs. This is most significant bit in that binary input. 12 = Jog enable, when closed, the jog speed defined at P2.3.8 will override the frequency reference. 13 = Accel. pot value, when closed, the motor potentiometer value will increment at the rate defined by motor pot ramp time. 14 = Decel. pot value, when closed, the motor potentiometer value will decrement at the rate defined by motor pot ramp time. 15 = Reset pot zero, when closed, the motor potentiometer value will reset to zero. 16 = Accel./decel. time set, when open, accel./decel. time 1 will be used. When closed, accel./decel. time 2 will be used. 17 = Accel./decel. prohibit, when closed, the drive will hold the output frequency and ignore changes to the reference value. 18 = No access to param., when closed, no changes can be made to any setting in the drive. 19 = Remote control, when closed, the drive will be forced to the remote control place. 20 = Local control, when closed, the drive will be forced to the local control place. 21 = Parameter 1/2 Sel., when open, parameter set 1 is active. When closed, Parameter set 2 is active. 22 = PI controller, when closed, the drive will force the reference source to PI controller output. 23 = PI setpoint select, when open, parameter setpoint 1 is active. When closed, setpoint 2 is active. 24 = Motor interlock 1, when closed, the motor will be enabled to run. 25 = Smoke mode, when closed, smoke mode will be active. 26 = Fire mode, when closed, fire mode will be active. 27 = Fire mode Ref. 1/2 Sel., when fire mode is active and this input is open, fire mode Ref. 1 will be active. When closed, fire mode Ref. 2 will be active. 28 = Fire mode reverse, when fire mode is active and this input is open, the direction will be forward. When closed, the direction will be reverse. 29 = DC brake active, when closed, DC injection braking will be active. 30 = Preheat active, when closed, preheat mode will be active. 31 = Derag. enable, when closed, the Derag. cycle for pumps will be initiated.				
Description:	Defines the function of virtual RO1.				
P2.2.10^②	Virtual RO1 invert				ID 1810
Minimum value:	N.A.	Maximum value:	N.A.	Default value:	0
Options:	0 = Disable; or 1 = Enable.				
Description:	When enabled, the function assigned to virtual RO1 input will be activated with the opposite state of virtual RO1 input.				

Appendix C Parameter Descriptions

Inputs (Cont.).

P2.2.11^②	Virtual RO2 input			ID 1811
Minimum value:	N.A.	Maximum value:	N.A.	Default value: 0
Options:	0 = Not used, no action. 1 = IO terminal start signal 1, when the control source is set to IO terminal, this input when closed will perform the action defined by P2.1.3. 2 = IO terminal start signal 3, when the control source is set to IO terminal, this input when closed will perform the action defined by P2.1.3. 3 = Reverse, when Start/Stop logic is set to three start pulse stop pulse, this input will cause the drive to start in the reverse direction. 4 = Ext. fault 1, when closed, Ext. fault 1 will be activated. 5 = Ext. fault 2, when closed, Ext. fault 2 will be activated. 6 = Ext. fault 3, when closed, Ext. fault 3 will be activated. 7 = Fault reset, when closed, all active faults will be reset. 8 = Run enable, when closed, the drive will allow a start command and be in the ready state. 9 = Preset speed B0, the seven preset speeds are selected via three binary inputs. This is least significant bit in that binary input. 10 = Preset speed B1, the seven preset speeds are selected via three binary inputs. 11 = Preset speed B2, the seven preset speeds are selected via three binary inputs. This is most significant bit in that binary input. 12 = Jog enable, when closed, the jog speed defined at P2.3.8 will override the frequency reference. 13 = Accel. pot value, when closed, the motor potentiometer value will increment at the rate defined by motor pot ramp time. 14 = Decel. pot value, when closed, the motor potentiometer value will decrement at the rate defined by motor pot ramp time. 15 = Reset pot zero, when closed, the motor potentiometer value will reset to zero. 16 = Accel./decel. time set, when open, accel./decel. time 1 will be used. When closed, accel./decel. time 2 will be used. 17 = Accel./decel. prohibit, when closed, the drive will hold the output frequency and ignore changes to the reference value. 18 = No access to param., when closed, no changes can be made to any setting in the drive. 19 = Remote control, when closed, the drive will be forced to the remote control place. 20 = Local control, when closed, the drive will be forced to the local control place. 21 = Parameter 1/2 Sel., when open, parameter set 1 is active. When closed, Parameter set 2 is active. 22 = PI controller, when closed, the drive will force the reference source to PI controller output. 23 = PI setpoint select, when open, parameter setpoint 1 is active. When closed, setpoint 2 is active. 24 = Motor interlock 1, when closed, the motor will be enabled to run. 25 = Smoke mode, when closed, smoke mode will be active. 26 = Fire mode, when closed, fire mode will be active. 27 = Fire mode Ref. 1/2 Sel., when fire mode is active and this input is open, fire mode Ref. 1 will be active. When closed, fire mode Ref. 2 will be active. 28 = Fire mode reverse, when fire mode is active and this input is open, the direction will be forward. When closed, the direction will be reverse. 29 = DC brake active, when closed, DC injection braking will be active. 30 = Preheat active, when closed, preheat mode will be active. 31 = Derag. enable, when closed, the Derag. cycle for pumps will be initiated.			
Description:	Defines the function of virtual RO2.			
P2.2.12^②	Virtual RO2 invert			ID 1812
Minimum value:	N.A.	Maximum value:	N.A.	Default value: 0
Options:	0 = Disable; or 1 = Enable.			
Description:	When enabled, the function assigned to virtual RO2 input will be activated with the opposite state of virtual RO2 input.			
P2.3 - Preset speed.				
P2.3.1^②	Preset speed 1			ID 105
Minimum value:	0.00 Hz	Maximum value:	MaxFreq Hz	Default value: 5.00 Hz
Description:	Preset speed is selected with digital inputs using a binary input.			
P2.3.2^②	Preset speed 2			ID 106
Minimum value:	0.00 Hz	Maximum value:	MaxFreq Hz	Default value: 10.00 Hz
Description:	Preset speed is selected with digital inputs using a binary input.			
P2.3.3^②	Preset speed 3			ID 118
Minimum value:	0.00 Hz	Maximum value:	MaxFreq Hz	Default value: 15.00 Hz
Description:	Preset speed is selected with digital inputs using a binary input.			
P2.3.4^②	Preset speed 4			ID 119
Minimum value:	0.00 Hz	Maximum value:	MaxFreq Hz	Default value: 20.00 Hz
Description:	Preset speed is selected with digital inputs using a binary input.			

Appendix C Parameter Descriptions

Inputs (Cont.).

P2.3.5^②	Preset speed 5			ID 120
Minimum value:	0.00 Hz	Maximum value:	MaxFreq Hz	Default value: 25.00 Hz
Description:	Preset speed is selected with digital inputs using a binary input.			
P2.3.6^②	Preset speed 6			ID 121
Minimum value:	0.00 Hz	Maximum value:	MaxFreq Hz	Default value: 30.00 Hz
Description:	Preset speed is selected with digital inputs using a binary input.			
P2.3.7^②	Preset speed 7			ID 122
Minimum value:	0.00 Hz	Maximum value:	MaxFreq Hz	Default value: 35.00 Hz
Description:	Preset speed is selected with digital inputs using a binary input.			
P2.3.8^②	Jog reference			ID 117
Minimum value:	MinFreq Hz	Maximum value:	MaxFreq Hz	Default value: 0.00 Hz
Description:	Defines the jogging speed set point - this speed is selected with the digital input programmed for jogging speed. When enabled, the drive starts and ramps to this speed, input removed drive stops.			

P2.4 - AI settings.

P2.4.1	AI mode			ID 222
Minimum value:	N.A.	Maximum value:	N.A.	Default value: 1
Options:	0 = 0 - 20 mA; or 1 = 0 - 10 V.			
Description:	<p>Defines the analog input mode to current or voltage the DIP switches on control board will need to be set to the same mode as this parameter.</p> <p>*EVM PRO CN5 terminals 8 and 9 for current or voltage, also need to set DIP switches SW2 2 and 3 on control board, near the RJ45 port.</p> <p>DIP switches SW2 2 and 3 off for voltage.</p> <p>Current mode, if using the +10 V supply on CN5 terminals 13 of the EVM / EVM Pro, it will require DIP switches SW2 2 and 3 on to complete the current loop. When doing a current loop with an external supply, the DIP switches SW2 2 off and 3 on.</p>			

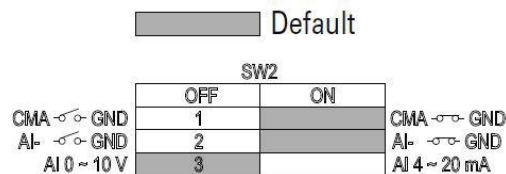

Appendix C Parameter Descriptions

Inputs (Cont.).

P2.4.2^②	AI signal range			ID 175
Minimum value:	N.A.	Maximum value:	N.A.	Default value: 0
Options:	0 = 0-100%/0-20 mA/0-10 V. 1 = 20-100%/4-20 mA/2-10 V. 2 = Customized.			
Description:	With this parameter, you can select the analog input 1 signal range. For selection "Customized," see "AI Custom Min" and "AI Custom Max", this enables a customized signal range.			

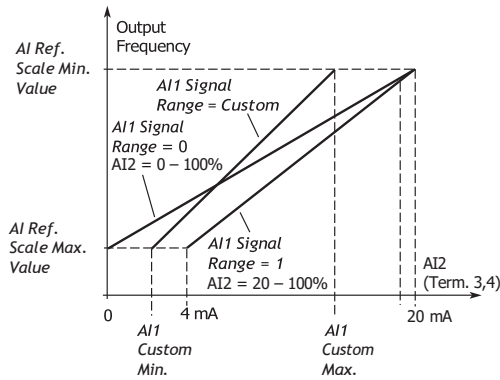

P2.4.3^②	AI custom minimum			ID 176
Minimum value:	0.00%	Maximum value:	Ai1CustomMax %	Default value: 0.00%
Descriptions:	Defines the minimum percentage for the input range to be associated with AI reference minimum scale.			
P2.4.4^②	AI custom maximum			ID 177
Minimum value:	Ai1CustomMin %	Maximum value:	100.00 %	Default value: 100.00%
Descriptions:	Defines the minimum percentage for the input range to be associated with AI reference maximum scale.			
P2.4.5^②	AI filter time			ID 174
Minimum value:	0.00 s	Maximum value:	10.00 s	Default value: 0.10 s
Descriptions:	Defines the filter time applied to the analog input signal, zero equals no filtering.			

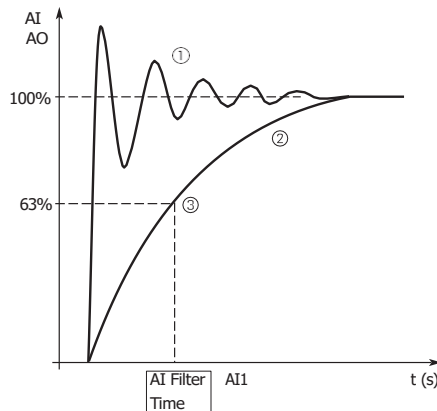

- Notes:**
- ① Analog signal with faults (unfiltered).
 - ② Filtered analog signal.
 - ③ Filter time constant at 63% of the set value.

Inputs (Cont.)

P2.4.6^②	AI signal invert	ID 181
Minimum value:	Maximum value:	Default value:
Options:	0 = Not invert; or 1 = Invert.	0
Descriptions:	Defines the filter time applied to the analog input signal, zero equals no filtering.	

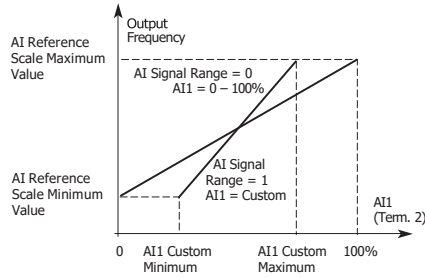

AI1 Signal Inversion

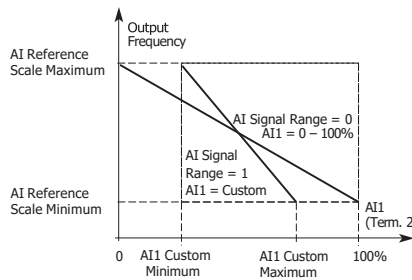

**Maximum AI1 signal = minimum set speed.
Minimum AI1 signal = maximum set speed.**

P2.4.7^②	AI joystick hysteresis	ID 178
Minimum value:	Maximum value:	Default value:
0.00%	20.00%	0.00%
Descriptions:	Defines the joystick hysteresis - when the analog input is within this range, the drive will interpret this as a zero speed reference.	

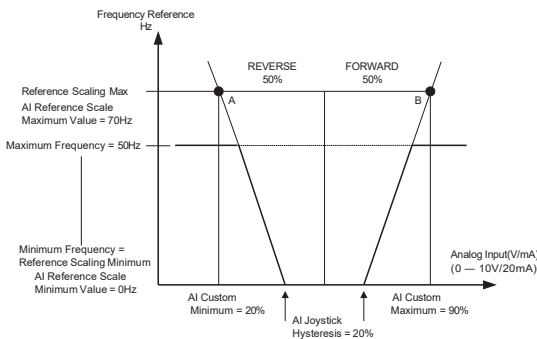

Appendix C Parameter Descriptions

Inputs (Cont.).

P2.4.8^②	AI sleep limit				ID 179
Minimum value:	0.00%	Maximum value:	100.00%	Default value:	0.00%
Descriptions:	Defines the sleep level of the analog input - if the analog input signal is below this level for a time greater than the analog sleep delay, the drive will transition to a sleep state and restart when the analog input increases above this level.				

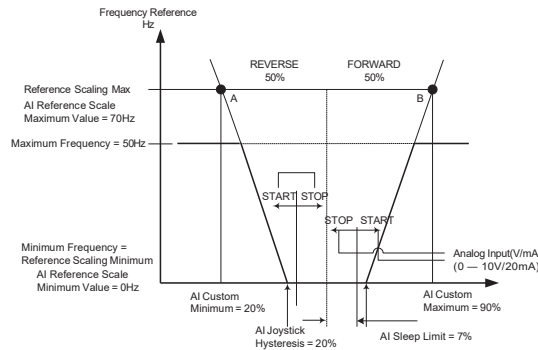

P2.4.9^②	AI sleep delay				ID 180
Minimum value:	0.00 s	Maximum value:	320.00 s	Default value:	0.00 s
Descriptions:	Defines the delay for the analog input sleep level.				
P2.4.10^②	AI joystick offset				ID 133
Minimum value:	-50.00%	Maximum value:	50.00%	Default value:	0.00%
Descriptions:	Joysticks zero point by default is the middle of AI range. Joystick offset defines how much the zero point is moved in the forward or reverse from this analog input center point.				

P2.5 - Drive reference pot.

P2.5.1^②	Pot custom minimum				ID 1814
Minimum value:	0.00%	Maximum value:	100.00%	Default value:	20.00%
Description:	Defines the minimum percentage for the input range to be associated with AI reference minimum scale.				
P2.5.2^②	Pot custom maximim				ID 1815
Minimum value:	0.00%	Maximum value:	100.00%	Default value:	100.00%
Description:	Defines the maximum percentage for the input range to be associated with AI reference maximum scale.				
P2.5.3^②	Pot filter time				ID 1816
Minimum value:	0.00 s	Maximum value:	10.00 s	Default value:	1.00 s
Description:	Defines the filter time applied to the analog input signal - zero equals no filtering.				

^① Parameter value can only be changed after the drive has stopped.

^② Parameter value will be set to be default when changing macros.

Appendix C Parameter Descriptions

Outputs

P3.1 - Digital output.					
P3.1.1 ^②	RO1 function				ID 152
Minimum value:	N.A.	Maximum value:	N.A.	Default value:	2
Options:	0 = Not used - no action; 1 = Ready - drive is ready for operation; 2 = Run - drive is running; 3 = Fault - drive is faulted; 4 = Fault invert - drive is not faulted; 5 = Warning - drive has a warning message; 6 = Reverse - drive is outputting reverse phase rotation; 7 = At speed - the output frequency has reached the set reference; 8 = Zero frequency - drive output is at zero frequency; 9 = Frequency limit supervision - supervision for frequency limit 1 is activated; 10 = PI supervision - supervision for PI controller is activated; 11 = Torque limit supervision - supervision for torque limit; 12 = Reference limit supervision - supervision for reference limit; 13 = Power limit supervision - supervision for power limit; 14 = Temperature limit supervision - supervision for drive temperature limit; 15 = Analog input supervision - supervision for analog input limit; 16 = Motor current supervision - supervision for motor current limit; 17 = Over heat fault - drive over heat fault has occurred; 18 = Over current regular - over current regulator is enabled; 19 = Over volt regular - over volt regulator is enabled; 20 = Under volt regular - under volt regulator is enabled; 21 = 4 mA fault - 4 mA fault has occurred; 22 = External fault - external fault has occurred; 23 = Motor thermal fault - motor thermal fault has occurred; 24 = STO fault output - safe torque Off input is activated; 25 = Control from IO - I/O is the selected start command location; 26 = Remote control - remote is the control place; 27 = Un-requested rotation direction - the active direction isn't the same as the reference direction; 28 = Fire mode - drive is in fire mode; 29 = Damper control - damper control output; 30 = Valve control - valve control output; 31 = Jog speed - drive is in jog mode; 32 = Fieldbus input 1 - controlled by fieldbus control word; 33 = Fieldbus input 2 - controlled by fieldbus control word; 34 = DC charge switch close - DC pre-charge relay is closed; 35 = Preheat active - preheat control mode is activated; 36 = Cold weather active - Cold weather mode is active; 37 = PI sleep - PI controller is in a sleep state; 38 = 2nd stage ramp frequency active - accel./decel. time 2 is active; 39 = Prime pump active - drive is running in prime pump mode; 40 = Master drive state - indicates it is the master drive in the multi-pump control mode; 41 = Slave drive state - indicates it is the slave drive in the multi-pump control mode; or 43 = Single drive control - indicates the motor contactor is open or close in multi-pump control mode.				
Description:	Defines the function associated with changing the state of relay output 1.				
P3.1.2 ^②	RO1 on delay				ID 2112
Minimum value:	0.0 s	Maximum value:	320.0 s	Default value:	0.0 s
Description:	Delay time for RO1 relay to turn on after signal received.				
P3.1.3 ^②	RO1 off delay				ID 2113
Minimum value:	0.0 s	Maximum value:	320.0 s	Default value:	0.0 s
Description:	Delay time for RO1 relay to turn off after signal removed.				

Appendix C Parameter Descriptions

Outputs (Cont.).

P3.1.4^②	RO2 function			ID 153
Minimum value:	N.A.	Maximum value:	N.A.	Default value: 3
Options:	0 = Not used - no action; 1 = Ready - drive is ready for operation; 2 = Run - drive is running; 3 = Fault - drive is faulted; 4 = Fault invert - drive is not faulted; 5 = Warning - drive has a warning message; 6 = Reverse - drive is outputting reverse phase rotation; 7 = At speed - the output frequency has reached the set reference; 8 = Zero frequency - drive output is at zero frequency; 9 = Frequency limit supervision - supervision for frequency limit 1 is activated; 10 = PI supervision - supervision for PI controller is activated; 11 = Torque limit supervision - supervision for torque limit; 12 = Reference limit supervision - supervision for reference limit; 13 = Power limit supervision - supervision for power limit; 14 = Temperature limit supervision - supervision for drive temperature limit; 15 = Analog input supervision - supervision for analog input limit; 16 = Motor current supervision - supervision for motor current limit; 17 = Over heat fault - drive over heat fault has occurred; 18 = Over current regular - over current regulator is enabled; 19 = Over volt regular - over volt regulator is enabled; 20 = Under volt regular - under volt regulator is enabled; 21 = 4 mA fault - 4 mA fault has occurred; 22 = External fault - external fault has occurred; 23 = Motor thermal fault - motor thermal fault has occurred; 24 = STO fault output - safe torque Off input is activated; 25 = Control from IO - I/O is the selected start command location; 26 = Remote control - remote is the control place; 27 = Un-requested rotation direction - the active direction isn't the same as the reference direction; 28 = Fire mode - drive is in fire mode; 29 = Damper control - damper control output; 30 = Valve control - valve control output; 31 = Jog speed - drive is in jog mode; 32 = Fieldbus input 1 - controled by fieldbus control word; 33 = Fieldbus input 2 - controled by fieldbus control word; 34 = DC charge switch close - DC pre-charge relay is closed; 35 = Preheat active - preheat control mode is activated; 36 = Cold weather active - Cold weather mode is active; 37 = PI sleep - PI controller is in a sleep state; 38 = 2nd stage ramp frequency active - accel./decel. time 2 is active; 39 = Prime pump active - drive is running in prime pump mode; 40 = Master drive state - indicates it is the master drive in the multi-pump control mode; 41 = Slave drive state - indicates it is the slave drive in the multi-pump control mode; or 43 = Single drive control - indicates the motor contactor is open or close in multi-pump control mode.			
Description:	Defines the function associated with changing the state of relay output 2.			
P3.1.5^②	RO2 on delay			ID 2114
Minimum value:	0.0 s	Maximum value:	320.0 s	Default value: 0.0 s
Description:	Delay time for RO2 relay to turn on after signal received.			
P3.1.6^②	RO2 off delay			ID 2115
Minimum value:	0.0 s	Maximum value:	320.0 s	Default value: 0.0 s
Description:	Delay time for RO2 relay to turn off after signal removed.			
P3.1.7^②	RO2 reverse			ID 2118
Minimum value:	N.A.	Maximum value:	N.A.	Default value: 0
Options:	0 = No; or 1 = Yes.			
Description:	Inverts RO2 to be normally closed on the Form A relay.			

Appendix C Parameter Descriptions

Outputs (Cont.).

P3.1.8 ^②	Virtual RO1 function			ID 2463
Minimum value:	N.A.	Maximum value:	N.A.	Default value: 2
Options:	0 = Not used - no action; 1 = Ready - drive is ready for operation; 2 = Run - drive is running; 3 = Fault - drive is faulted; 4 = Fault invert - drive is not faulted; 5 = Warning - drive has a warning message; 6 = Reverse - the drive is outputting reverse phase rotation; 7 = At speed - the output frequency has reached the set reference; 8 = Zero frequency - drive output is at zero frequency; 9 = Frequency limit supervision - supervision for frequency limit 1 is activated; 10 = PI supervision - supervision for PI controller is activated; 11 = Torque limit supervision - supervision for torque limit; 12 = Reference limit supervision - supervision for reference limit; 13 = Power limit supervision - supervision for power limit; 14 = Temperature limit supervision - supervision for drive temperature limit; 15 = Analog input supervision - supervision for analog input limit; 16 = Motor current supervision - supervision for motor current limit; 17 = Over heat fault - drive over heat fault has occurred; 18 = Over current regular - over current regulator is enabled; 19 = Over volt regular - over volt regulator is enabled; 20 = Under volt regular - under volt regulator is enabled; 21 = 4 mA fault - 4 mA fault has occurred; 22 = External fault - external fault has occurred; 23 = Motor thermal fault - motor thermal fault has occurred; 24 = STO fault output - safe torque off input is activated; 25 = Control from IO - I/O is the selected start command location; 26 = Remote control - remote is the control place; 27 = Unrequested rotation direction - the active direction is not the same as the reference direction; 28 = Fire mode - drive is in fire mode; 29 = Damper control - damper control output; 30 = Valve control - valve control output; 31 = Jog speed - drive is in jog mode; 32 = Fieldbus input 1 - controlled by FB control word; 33 = Fieldbus input 2 - controlled by FB control word; 34 = DC charge switch close - DC pre-charge relay is closed; 35 = Preheat active - preheat control mode is activated; 36 = Cold weather active - cold weather mode is active; 37 = PI sleep - PI controller is in a sleep state; 38 = 2nd stage ramp frequency active - accel./decel. time 2 is active; 39 = Prime pump active - drive is running in prime pump mode; 40 = Master drive state - indicates it is the master drive in the multi-pump control mode; 41 = Slave drive state - indicates it is the slave drive in the multi-pump control mode; or 43 = Single drive control - indicates the motor contactor is open or close in multi-pump control mode.			
Description:	Defines the function associated with changing the state of virtual RO.			

Appendix C Parameter Descriptions

Outputs (Cont.).

P3.1.9^②	Virtual RO2 function			ID 2464
Minimum value:	N.A.	Maximum value:	N.A.	Default value: 2
Options:	0 = Not used - no action; 1 = Ready - drive is ready for operation; 2 = Run - drive is running; 3 = Fault - drive is faulted; 4 = Fault invert - drive is not faulted; 5 = Warning - drive has a warning message; 6 = Reverse - the drive is outputting reverse phase rotation; 7 = At speed - the output frequency has reached the set reference; 8 = Zero frequency - drive output is at zero frequency; 9 = Frequency limit supervision - supervision for frequency limit 1 is activated; 10 = PI supervision - supervision for PI controller is activated; 11 = Torque limit supervision - supervision for torque limit; 12 = Reference limit supervision - supervision for reference limit; 13 = Power limit supervision - supervision for power limit; 14 = Temperature limit supervision - supervision for drive temperature limit; 15 = Analog input supervision - supervision for analog input limit; 16 = Motor current supervision - supervision for motor current limit; 17 = Over heat fault - drive over heat fault has occurred; 18 = Over current regular - over current regulator is enabled; 19 = Over volt regular - over volt regulator is enabled; 20 = Under volt regular - under volt regulator is enabled; 21 = 4 mA fault - 4 mA fault has occurred; 22 = External fault - external fault has occurred; 23 = Motor thermal fault - motor thermal fault has occurred; 24 = STO fault output - safe torque off input is activated; 25 = Control from IO - I/O is the selected start command location; 26 = Remote control - remote is the control place; 27 = Unrequested rotation direction - the active direction is not the same as the reference direction; 28 = Fire mode - drive is in fire mode; 29 = Damper control - damper control output; 30 = Valve control - valve control output; 31 = Jog speed - drive is in jog mode; 32 = Fieldbus input 1 - controlled by FB control word; 33 = Fieldbus input 2 - controlled by FB control word; 34 = DC charge switch close - DC pre-charge relay is closed; 35 = Preheat active - preheat control mode is activated; 36 = Cold weather active - cold weather mode is active; 37 = PI sleep - PI controller is in a sleep state; 38 = 2nd stage ramp frequency active - accel./decel. time 2 is active; 39 = Prime pump active - drive is running in prime pump mode; 40 = Master drive state - indicates it is the master drive in the multi-pump control mode; 41 = Slave drive state - indicates it is the slave drive in the multi-pump control mode; or 43 = Single drive control - indicates the motor contactor is open or close in multi-pump control mode.			
Description:	Defines the function associated with changing the state of virtual RO.			
P3.2 - Supervisions.				
P3.2.1^②	Frequency limit supervision			ID 154
Minimum value:	N.A.	Maximum value:	N.A.	Default value: 0
Options:	0 = No limit; 1 = Low limit supervision; or 2 = High limit Supervision.			
Description:	Selects how the drives frequency limit supervision controller functions.			
P3.2.2^②	Frequency limit display			ID 1821
Minimum value:	N.A.	Maximum value:	N.A.	Default value: 0
Options:	0 = Enable DO; 1 = Warning (W/O S)/enable DO; 2 = Warning (W S)/enable DO; or 3 = Fault/enable DO.			
Description:	Supervision display selection.			

Appendix C Parameter Descriptions

Outputs (Cont.).

P3.2.3^②	Frequency limit supervision value			ID 155
Minimum value:	0.00 Hz	Maximum value:	MaxFreq Hz	Default value: 0.00 Hz
Description:	Selects the frequency value supervised by the frequency limit supervision function.			
P3.2.4^②	Frequency limit supervision hysteresis			ID 2200
Minimum value:	0.10 Hz	Maximum value:	1.00 Hz	Default value: 0.10 Hz
Description:	This value selects the bandwidth between when the output frequency supervision enables and disables.			
P3.2.5^②	Torque limit supervision			ID 159
Minimum value:	N.A.	Maximum value:	N.A.	Default value: 0
Options:	0 = No limit; 1 = Low limit supervision; or 2 = High limit supervision.			
Description:	Supervision display selection.			
P3.2.6^②	Torque limit display			ID 1822
Minimum value:	N.A.	Maximum value:	N.A.	Default value: 0
Options:	0 = Enable DO; 1 = Warning (W/O S)/enable DO; 2 = Warning (W S)/enable DO; or 3 = Fault/enable DO.			
Description:	Supervision display selection.			
P3.2.7^②	Torque limit supervision value			ID 160
Minimum value:	-1,000.00%	Maximum value:	1,000.00%	Default value: 100.00%
Description:	Selects the torque value supervised by the torque limit supervision function.			
P3.2.8^②	Torque limit supervision hysteresis			ID 2202
Minimum value:	1.00%	Maximum value:	5.00%	Default value: 1.00%
Description:	This value selects the bandwidth between when the torque supervision enables and disables.			
P3.2.9^②	Reference limit supervision			ID 161
Minimum value:	N.A.	Maximum value:	N.A.	Default value: 0
Options:	0 = No limit; 1 = Low limit supervision; or 2 = High limit supervision.			
Description:	This value selects the bandwidth between when the torque supervision enables and disables.			
P3.2.10^②	Reference limit display			ID 1823
Minimum value:	N.A.	Maximum value:	N.A.	Default value: 0
Options:	0 = Enable DO; 1 = Warning (W/O S)/enable DO; 2 = Warning (W S)/enable DO; or 3 = Fault/enable DO.			
Description:	Supervision display selection.			

Appendix C Parameter Descriptions

Outputs (Cont.).

P3.2.11^②	Reference limit supervision value			ID 162
Minimum value:	0.00 Hz	Maximum value:	MaxFreq Hz	Default value: 0.00 Hz
Description:	Selects the reference frequency value supervised by the reference frequency limit supervision function.			
P3.2.12^②	Reference limit supervision hysteresis			ID 12203
Minimum value:	0.10 Hz	Maximum value:	1.00 Hz	Default value: 0.10 Hz
Description:	This value selects the bandwidth between when the reference limit supervision enables and disables.			
P3.2.13^②	Temperature limit supervision			ID 165
Minimum value:	N.A.	Maximum value:	N.A.	Default value: 0
Options:	0 = No limit; 1 = Low limit supervision; or 2 = High limit supervision.			
Description:	Selects how the drives temperature limit supervision controller functions.			
P3.2.14^②	Temperature limit display			ID 1824
Minimum value:	N.A.	Maximum value:	N.A.	Default value: 0
Options:	0 = Enable DO; 1 = Warning (W/O S)/enable DO; 2 = Warning (W S)/enable DO; or 3 = Fault/enable DO.			
Description:	Supervision display selection.			
P3.2.15^②	Temperature limit supervision value			ID 166
Minimum value:	-10.0° C	Maximum value:	75.0° C	Default value: 40.0° C
Description:	Selects the drive temperature value supervised by the drive temperature limit supervision function.			
P3.2.16^②	Temperature limit supervision hysteresis			ID 2204
Minimum value:	1.0° C	Maximum value:	10.0° C	Default value: 1.0° C
Description:	This value selects the bandwidth between when the temperature limit supervision enables and disables.			
P3.2.17^②	Power limit supervision			ID 167
Minimum value:	N.A.	Maximum value:	N.A.	Default value: 0
Options:	0 = No limit; 1 = Low limit supervision; or 2 = High limit supervision.			
Description:	Selects how the drives power limit supervision controller function.			
P3.2.18^②	Power limit display			ID 1825
Minimum value:	N.A.	Maximum value:	N.A.	Default value: 0
Options:	0 = Enable DO; 1 = Warning (W/O S)/enable DO; 2 = Warning (W S)/enable DO; or 3 = Fault/enable DO.			
Description:	Supervision display selection.			
P3.2.19^②	Power limit supervision value			ID 168
Minimum value:	-200.0%	Maximum value:	200.0%	Default value: 0.0%
Description:	Selects the output power value supervised by the power limit supervision function.			
P3.2.20^②	Power limit supervision hysteresis			ID 2205
Minimum value:	0.1%	Maximum value:	10.0%	Default value: 0.1%
Description:	This value selects the bandwidth between when the power limit supervision enables and disables.			

Appendix C Parameter Descriptions

Outputs (Cont.).

P3.2.21^②	AI supervision select			ID 170
Minimum value:	N.A.	Maximum value:	N.A.	Default value: 0
Options:	0 = Analog reference from AI; or 1 = Analog reference from keypad potentiometer.			
Description:	Selects analog signal to use for the analog input supervision.			
P3.2.22^②	AI limit supervision			ID 171
Minimum value:	N.A.	Maximum value:	N.A.	Default value: 0
Options:	0 = No limit; 1 = Low limit supervision; or 2 = High limit supervision.			
Description:	Selects analog signal to use for the analog input supervision.			
P3.2.23^②	AI limit display			ID 1826
Minimum value:	N.A.	Maximum value:	N.A.	Default value: 0
Options:	0 = Enable DO; 1 = Warning (W/O S)/enable DO; 2 = Warning (W S)/enable DO; or 3 = Fault/enable DO.			
Description:	Supervision display selection.			
P3.2.24^②	AI limit supervision value			ID 172
Minimum value:	0.00%	Maximum value:	10.00%	Default value: 0.00%
Description:	Selects the analog reference value supervised by the analog reference limit supervision function.			
P3.2.25^②	AI supervision hysteresis			ID 2198
Minimum value:	1.00%	Maximum value:	10.00%	Default value: 1.00%
Description:	This value selects the bandwidth between when the AI supervision enables and disables.			
P3.2.26^②	Motor current supervision			ID 2189
Minimum value:	N.A.	Maximum value:	N.A.	Default value: 0
Options:	0 = No limit; 1 = Low limit supervision; or 2 = High limit supervision.			
Description:	Selects how the motor current limit supervision controller functions.			
P3.2.27^②	Motor current limit display			ID 1827
Minimum value:	N.A.	Maximum value:	N.A.	Default value: 0
Options:	0 = Enable DO; 1 = Warning (W/O S)/enable DO; 2 = Warning (W S)/enable DO; or 3 = Fault/enable DO.			
Description:	Supervision display selection.			
P3.2.28^②	Motor current supervision value			ID 2190
Minimum value:	0.00 A	Maximum value:	DriveNomCurrCT*2 A	Default value: DriveNomCurrCT A
Description:	Selects the motor current value supervised by the motor current limit supervision function.			
P3.2.29^②	Motor current supervision hysteresis			ID 2196
Minimum value:	0.10 A	Maximum value:	1.00 A	Default value: 0.10 A
Description:	This value selects the bandwidth between when the motor current supervision enables and disables.			

Appendix C Parameter Descriptions

Outputs (Cont.).

P3.2.30^②	PI supervision enable			ID 1346
Minimum value:	N.A.	Maximum value:	N.A.	Default value: 0
Options:	0 = Disabled; or 1 = Enabled.			
Description:	Upper and lower limits around the reference are set. When the actual value goes above or below the upper limit and lower limit, the delay timer will increment. When the actual value is within the allowed area, the delay counter decrements. After the delay time expires, the relay output for PI supervision will be activated. This function is used for process value out of range faults.			
P3.2.31^②	PI supervision display			ID 1828
Minimum value:	N.A.	Maximum value:	N.A.	Default value: 0
Options:	0 = Enable DO; 1 = Warning (W/O S)/enable DO; 2 = Warning (W S)/enable DO; or 3 = Fault/enable DO.			
Description:	Supervision display selection.			
P3.2.32^②	PI supervision upper limit			ID 1347
Minimum value:	PI Process Unit Min varies	Maximum value:	PI Process Unit Max varies	Default value: 0.00 varies
Description:	Upper limit for PI feedback value used with the PI supervision controller.			
P3.2.33^②	PI supervision lower limit			ID 1349
Minimum value:	PI Process Unit Min varies	Maximum value:	PI Process Unit Max varies	Default value: 0.00 varies
Description:	Lower limit for PI feedback value used with the PI supervision controller.			
P3.2.34^②	PI supervision delay			ID 1351
Minimum value:	0 s	Maximum value:	3,000 s	Default value: 0 s
Description:	Defines the delay time that the PI feedback value must be out of range before activating the PI supervision output.			
P3.3 - Analog output.				
P3.3.1^②	AO mode			ID 227
Minimum value:	N.A.	Maximum value:	N.A.	Default value: 0
Options:	0 = 0 - 20 mA; or 1 = 0 - 10 V.			
Description:	Defines the analog output mode to current or voltage.			

Appendix C Parameter Descriptions

Outputs (Cont.).

P3.3.2^②	AO function			ID 146
Minimum value:	N.A.	Maximum value:	N.A.	Default value: 1
Options:	1 = Output frequency (0 - mMax frequency); 2 = Frequency reference (0 - max frequency); 3 = Motor speed RPM (0 - nameplate RPM); 4 = Motor current (0 - nameplate current); 5 = Motor torque (0 - calculated nominal); 6 = Motor power (0 - calculated nominal); 7 = Motor voltage (0 - nameplate voltage); 8 = DC bus voltage (0 - 1000 Vdc); 9 = PI setpoint (process unit minimum - process unit maximum); 10 = PI error value (process unit minimum - process unit maximum); 11 = PI output (process unit minimum - process unit maximum); 12 = Analog input (0% - 100%); 13 = Drive reference potentiometer (0% - 100%); 14 = Fieldbus process data input 1 (0% - 100%); 15 = Fieldbus process data input 2 (0% - 100%); 16 = Fieldbus process data input 3 (0% - 100%); 17 = Fieldbus process data input 4 (0% - 100%); 18 = Fieldbus process data input 5 (0% - 100%); 19 = Fieldbus process data input 6 (0% - 100%); 20 = Fieldbus process data input 7 (0% - 100%); 21 = Fieldbus process data input 8 (0% - 100%); 22 = User defined output (user defined minimum - user defined maximum); 23 = Motor torque (0% - 200%); or 24 = Motor power absolute value (0% - 100%).			
Description:	Select the function desired to the terminal AO1.			
P3.3.3^②	AO filter time			ID 147
Minimum value:	0.00 s	Maximum value:	10.00 s	Default value: 1.00 s
Description:	Defines the filter time applied to the analog output signal. Zero equals no filtering.			
				Notes ① Analog signal with faults (unfiltered). ② Filtered analog signal. ③ Filter time constant at 63% of the set value.
P3.3.4^②	AO custom minimum			ID 1863
Minimum value:	N.A.%	Maximum value:	N.A.%	Default value: 0.00%
Description:	Input axis start point x1, define AO function selected signal minimum value (percent) that user wants. Default value is 0. Negative value shall be allowed for x1. From (x1, y1) and (x2, y2) will get gain and offset. Then expected AO will calculate from gain and offset.			
P3.3.5^②	AO custom maximum			ID 1865
Minimum value:	N.A.%	Maximum value:	N.A.%	Default value: 100.00%
Description:	Input axis end point x2, define AO function selected signal maximum value (percent) that user wants. Default value is 100%. Negative value shall be allowed for x2. From (x1,y1) and (x2,y2) will get gain and offset. Then expected AO will calculate from gain and offset.			

Appendix C Parameter Descriptions

Outputs (Cont.).

P3.3.6^②	AO value minimum			ID 1867
Minimum value:	0.00 varies	Maximum value:	100.00 varies	Default value: 0.00 varies
Description:	Start point output axis y1, define AO value selected by AO mode, y1 is related to x1. mA Default value is 0 mA. From (x1,y1) and (x2,y2) will get gain and offset. Then expected AO will calculate from gain and offset.			
P3.3.7^②	AO value maximum			ID 1868
Minimum value:	0.00 varies	Maximum value:	100.00 varies	Default value: 20.00 varies
Description:	End point output axis y2, define AO value selected by AO mode, y2 is related to x2. Default value is 20 mA. From (x1,y1) and (x2,y2) will get gain and offset. Then expected AO will calculate from gain and offset.			

^② Parameter value will be set to be default when changing macros.

Drive control

P4.1 - Basic settings.				
P4.1.1^②	Keypad reference			ID 141
Minimum value:	MinFreq Hz	Maximum value:	MaxFreq HZ	Default value: 0.00 Hz
Description:	Keypad reference value.			
P4.1.2^②	Keypad/drive reference pot direction			ID 116
Minimum value:	N.A.	Maximum value:	N.A.	Default value: 0
Options"	0 = Forward; or 1 = Reverse.			
Description:	Forward - the rotation of the motor is forward or clockwise direction, when the keypad is the active control place. Reverse - the rotation of the motor is reversed or counter clockwise direction, when the keypad is the active control place.			
P4.1.3^②	Keypad stop			ID 114
Minimum value:	N.A.	Maximum value:	N.A.	Default value: 1
Options:	0 = Enabled - keypad operation - In this mode, the keypad stop will only operate when the control source is set to keypad. 1 = Always enabled - In this mode, the stop button will always stop the drive regardless of control mode.			
Description:	Enabled or always enabled keypad operation.			
P4.1.4^①	Reverse enabled			ID 1679
Minimum value:	N.A.	Maximum value:	N.A.	Default value: 1
Options:	0 = Disabled; or 1 = Enabled.			
Description:	Enables or disables the reverse motor direction.			
P4.1.5	Change phase sequence motor			ID 2515
Minimum value:	N.A.	Maximum value:	N.A.	Default value: 0
Options:	0 = Change disable; or 1 = Change enable.			
Description:	This parameter allows for swapping the motor phase output from u, v, w to u, w, v.			
P4.1.6^②	Power up local remote select			ID 1685
Minimum value:	N.A.	Maximum value:	N.A.	Default value: 0
Options:	0 = Hold last; 1 = Local control; or 2 = Remote control.			
Description:	Selects what control place the drive will start at after power is applied. The default setting will hold the last state that the drive was in when powered down, selecting Local or Remote will cause the drive to start in that mode regardless of last state.			

Appendix C Parameter Descriptions

Drive control (Cont.).

P4.1.8^②	Start mode			ID 252
Minimum value:	N.A.	Maximum value:	N.A.	Default value: 0
Options:	0 = Ramp - The drive starts from 0 Hz and ramps to the frequency reference value. 1 = Flying start from stop frequency - The drive will catch a spinning motor. This setting searches for the current frequency using the last operating frequency as a starting point. 2 = Flying start from maximum frequency - The drive will catch a spinning motor. This setting searches for the current frequency using the maximum operating frequency as a starting point.			
Description:	Selects the start mode operation.			
P4.1.9^②	Stop mode			ID 253
Minimum value:	N.A.	Maximum value:	N.A.	Default value: 1
Options:	0 = Coasting - After a stop command, the motor coasts to a stop uncontrolled by the drive. 1 = Ramp - After the stop command, the speed of the motor is decelerated according to the set deceleration parameters.			
Description:	Selects the stop mode operation.			
P4.1.10^②	Ramp 1 shape			ID 247
Minimum value:	0.0 s	Maximum value:	10.0 s	Default value: 0.0 s
Description:	The start and end of the acceleration and deceleration ramps can be smoothed with these parameters. Setting a value of 0.00 seconds gives a linear ramp shape that causes acceleration and deceleration to react immediately to the changes in the reference signal. Setting a value from 0.10 to 10.00 seconds for this parameter produces an S-shaped acceleration/deceleration at the start and stop of the slope.			

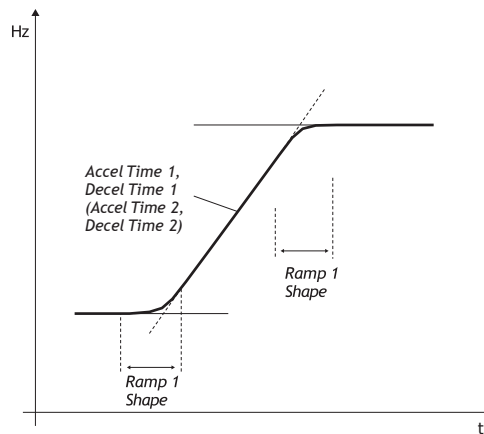

Appendix C Parameter Descriptions

Drive control (Cont.).

P4.1.11^②	Ramp 2 shape				ID 248
Minimum value:	0.0 s	Maximum value:	10.0 s	Default value:	0.0 s
Description:	<p>The start and end of the acceleration and deceleration ramps can be smoothed with these parameters. Setting a value of 0.00 gives a linear ramp shape that causes acceleration and deceleration to react immediately to the changes in the reference signal.</p> <p>Setting a value from 0.10 to 10.00 seconds for this parameter produces an S-shaped acceleration/deceleration at the start and stop of the slope.</p>				
P4.1.12^②	Accel. time 2				ID 249
Minimum value:	0.1 s	Maximum value:	3000.0 s	Default value:	10.0 s
Description:	<p>These values correspond to the time required for the output frequency to accelerate from the zero frequency to the set maximum frequency.</p> <p>These parameters provide the possibility to set two different acceleration/deceleration time sets for one application. The active set can be selected with the programmable digital input.</p>				
P4.1.13^②	Decel. time 2				ID 250
Minimum value:	0.1 s	Maximum value:	3000.0 s	Default value:	10.0 s
Description:	<p>These values correspond to the time required for the output frequency to decelerate from the set maximum frequency to the zero frequency.</p> <p>These parameters provide the possibility to set two different acceleration/deceleration time sets for one application. The active set can be selected with the programmable digital input.</p>				
P4.1.14^{①②}	2nd Stage ramp frequency				ID 2444
Minimum value:	MinFreq Hz	Maximum value:	MaxFreq Hz	Default value:	30.00 Hz
Description:	<p>When 2nd stage ramp frequency is the frequency level at which the drive will enable the 2nd stage ramp frequency output function. This then can be used for other inputs or devices to signal a frequency level.</p>				
P4.1.15^{①②}	Fault reset start				ID 2483
Minimum value:	N.A.	Maximum value:	N.A.	Default value:	0
Options:	<p>0 = Start/stop after fault reset - the run command has to be cycled to restart after fault reset; or 1 = Restart after fault reset - the run command is still active after fault the drive will restart without re-sending command.</p>				
Description:	<p>Defines how the drive run command responds after a fault reset command.</p>				
P4.2 - Brake.					
P4.2.1^{①②}	Brake chopper enable				ID 1829
Minimum value:	N.A.	Maximum value:	N.A.	Default value:	0
Options:	<p>0 = Disable - dynamic brake OFF; or 1 = Enable - dynamic brake ON.</p>				
Description:	<p>If an external resistor is connected to the drive setting, this parameter to enabled will allow excess DC bus voltage to be bled off through the attached resistor.</p>				

Appendix C Parameter Descriptions

Drive control (Cont.).

P4.2.2^{①②}	DC brake current				ID 254
Minimum value:	DriveNomCurrCT*15/100 A	Maximum value:	DriveNomCurrCT*15/10 A	Default value:	DriveNomCurrCT*1/2 A
Description:	Defines the current level injected into the motor during DC-braking.				
P4.2.3^{①②}	Start DC brake time				ID 263
Minimum value:	0.00 s	Maximum value:	600.00 s	Default value:	0.00 s
Description:	This parameter defines the time the drive injects DC braking current before starting to ramp. This can be used to stop motors that are potentially spinning before a run command is given or before ramping to reference level. This is to stop motors that are potentially spinning before a run command is given.				
P4.2.4^{①②}	Stop DC brake frequency				ID 262
Minimum value:	0.10 Hz	Maximum value:	10.00 Hz	Default value:	1.50 Hz
Description:	During a ramp to stop, this parameter defines the output frequency to be below to begin DC braking.				
P4.2.5^{①②}	Stop DC brake time				ID 255
Minimum value:	0.00 s	Maximum value:	600.00 s	Default value:	0.00 s
Description:	Determines the length of DC braking while stopping. 0.00 = DC brake is not used; or >0.0 = The amount of time DC-braking will occur after falling below the stop DC brake frequency.				

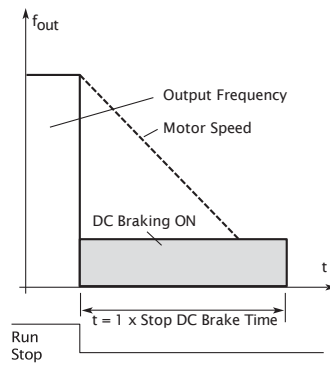

DC braking time when stop mode = coasting.

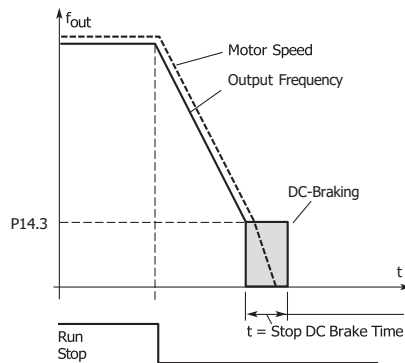

DC braking time when stop mode = ramp.

Appendix C Parameter Descriptions

Drive control (Cont.).

P4.2.6 ^{①②}	Flux brake			ID 266
Minimum value:	N.A.	Maximum value:	N.A.	Default value: 0
Options:	0 = Flux braking OFF; or 1 = Flux braking ON.			
Description:	While stopping, the output frequency is reduced and the flux in the motor is increased, which in turn increases the motor's capability to brake. Unlike DC braking, the motor speed remains controlled during braking. The flux braking can be set ON or OFF.			
	Note: Flux braking converts the energy into heat in the motor and should be used carefully to avoid motor damage.			
P4.2.7 ^{①②}	Flux brake current			ID 265
Minimum value:	MotorNomCurr*1/10 A	Maximum value:	CurrLimit A	Default value: MotorNomCurr*1/2 A
Description:	Defines the flux braking current value output when flux brake is enabled.			

P4.3 - Skip frequency.

P4.3.1 ^②	Skip range ramp factor			ID 264
Minimum value:	0.1	Maximum value:	10.0	Default value: 1.0
Description:	Defines the acceleration/deceleration time when the output frequency is between the selected prohibit frequency range limits. The ramping speed (selected acceleration/deceleration time 1 or 2) is multiplied with this factor: e.g., value 0.1 makes the acceleration time 10 times shorter than outside the prohibit frequency range limits.			

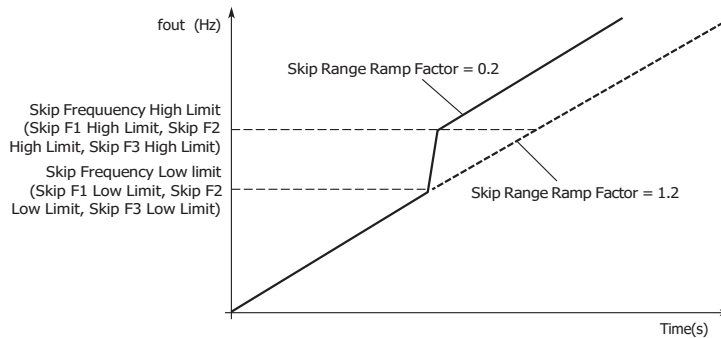

Ramp speed scaling between skip frequencies.

P4.3.2 ^②	Skip F1 low limit			ID 256
Minimum value:	0.00 Hz	Maximum value:	SkipRange1HighLimit Hz	Default value: 0.00 Hz
Description:	Defines the acceleration/deceleration time when the output frequency is between the selected prohibit frequency range limits. The ramping speed (selected acceleration/deceleration time 1 or 2) is multiplied with this factor: e.g., value 0.1 makes the acceleration time 10 times shorter than outside the prohibit frequency range limits.			
P4.3.3 ^②	Skip F1 high limit			ID 257
Minimum value:	SkipRange1LowLimit Hz	Maximum value:	400.00 Hz	Default value: 0.00 Hz
Description:	Defines the acceleration/deceleration time when the output frequency is between the selected prohibit frequency range limits. The ramping speed (selected acceleration/deceleration time 1 or 2) is multiplied with this factor: e.g., value 0.1 makes the acceleration time 10 times shorter than outside the prohibit frequency range limits.			
P4.3.4 ^②	Skip F2 low limit			ID 258
Minimum value:	0.00 Hz	Maximum value:	SkipRange2HighLimit Hz	Default value: 0.00 Hz
Description:	Defines the acceleration/deceleration time when the output frequency is between the selected prohibit frequency range limits. The ramping speed (selected acceleration/deceleration time 1 or 2) is multiplied with this factor: e.g., value 0.1 makes the acceleration time 10 times shorter than outside the prohibit frequency range limits.			
P4.3.5 ^②	Skip F2 high limit			ID 259
Minimum value:	SkipRange2LowLimit Hz	Maximum value:	400.00 Hz	Default value: 0.00 Hz
Description:	Defines the acceleration/deceleration time when the output frequency is between the selected prohibit frequency range limits. The ramping speed (selected acceleration/deceleration time 1 or 2) is multiplied with this factor: e.g., value 0.1 makes the acceleration time 10 times shorter than outside the prohibit frequency range limits.			

Appendix C Parameter Descriptions

Drive control (Cont.).

P4.3.6^②	Skip F3 low limit			ID 260
Minimum value:	0.00 Hz	Maximum value:	SkipRange3HighLimit Hz	Default value: 0.00 Hz
Description:	Defines the acceleration/deceleration time when the output frequency is between the selected prohibit frequency range limits. The ramping speed (selected acceleration/deceleration time 1 or 2) is multiplied with this factor: e.g., value 0.1 makes the acceleration time 10 times shorter than outside the prohibit frequency range limits.			
P4.3.7^②	Skip F3 high limit			ID 261
Minimum value:	SkipRange3LowLimit HZ	Maximum value:	400.00 Hz	Default value: 0.00 Hz
Description:	Defines the acceleration/deceleration time when the output frequency is between the selected prohibit frequency range limits. The ramping speed (selected acceleration/deceleration time 1 or 2) is multiplied with this factor: e.g., value 0.1 makes the acceleration time 10 times shorter than outside the prohibit frequency range limits.			
P4.4 - Energy savings calculations.				
P4.4.1^②	Currency			ID 2122
Minimum value:	N.A.	Maximum value:	N.A.	Default value: 0
Options:	0 = \$; 1 = £; 2 = €; 3 = ¥; 4 = R\$; 5 = R\$; 6 = Fr; or 7 = kr.			
Description:	Sets the local currency used for energy savings estimation.			
P4.4.2^②	Energy cost			ID 2123
Minimum value:	Varies	Maximum value:	Varies	Default value: 0.00 varies
Description:	Sets the local energy cost per kW. Used for energy savings estimation.			
P4.4.3^②	Data type			ID 2124
Minimum value:	N.A.	Maximum value:	N.A.	Default value: 0
Options:	0 = Cumulative; 1 = Daily average; 2 = Weekly average; 3 = Monthly average; or 4 = Yearly average.			
Description:	Selects the format to view energy savings. The drive takes four recordings in an hour and then calculates the average based off this parameter. The savings estimation is based on comparing the drives energy usage compared to a across the line starter.			
P4.4.4	Energy savings reset			ID 2125
Minimum value:	N.A.	Maximum value:	N.A.	Default value: N.A.
Options:	0 = Not reset; or 1 = Reset.			
Description:	Resets the energy savings value.			

^① Parameter value can only be changed after the drive has stopped.

^② Parameter value will be set to be default when changing macros.

Appendix C Parameter Descriptions

P4.5: Temperature Foldback

P4.5.1	IGBT Temperature	Modbus ID:	776
Min Value	Max Value	Default Value	RO/RW
N/A	N/A	N/A	RO
Description:	VFD IGBT Temperature Estimate - Read only.		
P4.5.2	Foldback status	Modbus ID:	1771
Min Value	Max Value	Default Value	RO/RW
N/A	N/A	N/A	RO
Description:	Foldback status. It is a monitor parameter. There are three values: (0) inactive, when IGBT temperature is smaller than Recovering temperature (1) active, when IGBT temperature is greater than foldback temperature (2) on hold, when IGBT temperature is between Recovering temperature and Foldback temperature		
P4.5.3	Foldback output frequency		
Min Value	Max Value	Default Value	RO/RW
N/A	N/A	N/A	RO
Description:	Foldback output, it is the frequency. It is a monitor parameter, unit is Hz.		
P4.5.4	Foldback output speed		
Min Value	Max Value	Default Value	RO/RW
N/A	N/A	N/A	RO
Description:	Foldback output, it is the speed. It is a monitor parameter, unit is rpm		
P4.5.5	Foldback enable		
Min Value	Max Value	Default Value	RO/RW
N/A	N/A	Disabled (0)	RO
Description:	Foldback enable (0) Disable (1) Enable		
P4.5.6	Foldback temperature	Modbus ID:	1775
Min Value	Max Value	Default Value	RO/RW
	0		120
Description:	Foldback temperature. It is a user-setting parameter. Display unit is Deg. C. If IGBT temperature is greater than Foldback temperature, the speed shall be reduced at the rate "speed reduce rate"		
P4.5.7	Recovering temperature	Modbus ID:	1776
Min Value	Max Value	Default Value	RO/RW
	0		120
Description:	Recovering temperature. It is a user-setting parameter. Display unit Deg. C. If IGBT temperature is between Recovering temperature and Foldback temperature, the speed shall remain the current speed.		
P4.5.8	Foldback speed reduce rate	Modbus ID:	1777
Min Value	Max Value	Default Value	RO/RW
	0		200
Description:	Foldback speed reduce rate. It is a user-setting parameter, unit is rpm/s. If IGBT temperature is greater than Foldback temperature, the speed shall be reduced at the rate "foldback speed reduce rate"		
P4.5.9	Foldback minimum speed	Modbus ID:	1778
Min Value	Max Value	Default Value	RO/RW
	0		10000
Description:	Foldback fault trip speed. It is a user-setting parameter, unit is rpm. If the drive is "foldback active" and speed is less than "Foldback minimum speed", this status lasts "Foldback fault timeout", Foldback fault will happen.		
P4.5.10	Foldback fault timeout	Modbus ID:	1779
Min Value	Max Value	Default Value	RO/RW
	0		200
Description:	Foldback fault timeout. It is a user-setting parameter, unit is second. If the drive is "foldback active" and speed is less than "Foldback minimum speed", this status lasts "Foldback fault timeout", Foldback fault will happen.		

Appendix C Parameter Descriptions

Motor control

P5.1 - Basic settings.				
P5.1.1 ^{①②}	Motor control mode			ID 287
Minimum value:	N.A.	Maximum value:	N.A.	Default value: 0
Options:	0 = Frequency control - Output frequency is controlled directly by the frequency reference. 1 = Speed control - Output frequency is controlled by giving a frequency reference to it with slip compensation. 2 = Open loop vector control - Similar to the standard speed control mode, higher performance slip calculation requires running a motor identification. 3 = PM control 1 - PM motor control mode 1, used for SPM (surface mounted permanent magnet) and it also can be used for IPM. 4 = PM control 2 - PM motor control mode 2, used for IPM (internally mounted permanent magnet) and it can not be used for SPM.			
Description:	Selects the motor control mode.			
P5.1.2 ^①	Current output limit			ID 107
Minimum value:	DriveNomCurrCT*1/10 A	Maximum value:	DriveNomCurrCT*2 A	Default value: DriveNomCurrCT*2 A
Description:	This parameter determines the maximum output current allowed from the drive. The parameter value range differs from size to size. Once the motor current hits this level, it goes into the current limiter controller and tries to limit the output current. This is not a fault trip limit.			
P5.1.3 ^{①②}	V/Hz optimization			ID 109
Minimum value:	N.A.	Maximum value:	N.A.	Default value: 0
Options:	0 = Disable torque boost function. 1 = Enable torque boost function.			
Description:	Automatic torque boost - the voltage to the motor increases automatically, which assists the motor to produce sufficient torque to start and run at low frequencies with high loads.			
P5.1.4 ^{①②}	V/Hz ratio			ID 108
Minimum value:	N.A.	Maximum value:	N.A.	Default value: 0
Options:	0 = Linear - the voltage of the motor changes linearly with the frequency in the constant flux area from 0 Hz to the field weakening point where the nominal voltage is supplied. A linear V/Hz ratio should be used in constant torque applications. 1 = Squared - the voltage of the motor changes following a squared curve with the frequency in the area from 0 Hz to the field weakening point where the nominal voltage is supplied. The motor runs under magnetized below the field weakening point and produces less torque and electromechanical noise. A squared V/Hz ratio can be used in applications where the torque demand of the load is proportional to the square of the speed. 2 = Programmable V/Hz curve - the V/Hz curve can be programmed with three different points. These points are the 0 frequency voltage, midpoint and weakening point. A programmable V/Hz curve can be used if the other settings do not satisfy the needs of the application. 3 = Linear with flux optimization - the drive starts to search for the minimum motor current in order to save energy. This mode is called Copeland's Energy Control which will reduce the voltage and current but still maintain the desired speed.			
Description:	Selects the V/Hz ratio. 0 = Linear; 1 = Squared; 2 = Programmable; or 3 = Linear + flux optimization.			

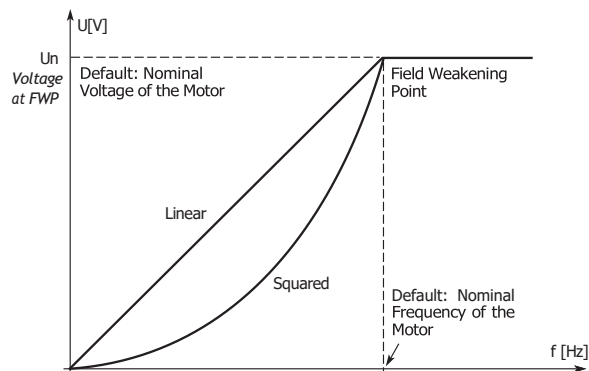

P5.1.5 ^{①②}	Field weakening point			ID 289
Minimum value:	8.00 Hz	Maximum value:	400.00 Hz	Default value: FieldWeakPointMFG Hz
Description:	The field weakening point is the frequency at which the output voltage reaches the set maximum value. This value is usually determined by the motor nameplate value.			

Appendix C Parameter Descriptions

Motor control (Cont.).

P5.1.6^{①②}	Voltage at FWP				ID 290
Minimum value:	10.00%	Maximum value:	200.00%	Default value:	00.00%
Description:	Defines the voltage at the field weakening point, when the output frequency exceeds the field weakening point, the voltage will remain constant.				
P5.1.7^{①②}	VV/Hz mid frequency				ID 291
Minimum value:	0.00 H	Maximum value:	FieldWeakPoint Hz	Default value:	VHzCurveMidFreqMFG Hz
Description:	If the programmable V/Hz curve has been selected, this parameter defines the midpoint frequency of the curve. This value can be set anywhere between 0 and the field weakening point. To either have a different V/Hz ramp or if set to the FWP, it will provide the field weakening point voltage all the way up the curve.				
P5.1.8^{①②}	VV/Hz mid voltage				ID 292
Minimum value:	0.00%	Maximum value:	100.00%	Default value:	100.00%
Description:	If the programmable V/Hz curve has been selected, this parameter defines the mid-point voltage of the curve. This value can be set anywhere between zero frequency volt and the field weakening point voltage.				
P5.1.9^{①②}	Zero frequency voltage				ID 293
Minimum value:	0.00%	Maximum value:	40.00%	Default value:	0.00%
Description:	If the programmable V/Hz curve has been selected, this parameter defines the zero frequency voltage of the curve.				
P5.1.10^②	Switching frequency				ID 2522
Minimum value:	MinSwitchFreq kHz	Maximum value:	MaxSwitchFreq kHz	Default value:	DefaultSwitchFreqCT kHz
Description:	Sets the switching frequency for the PWM output waveform.				
P5.1.11^②	Sine filter enabled				ID 1665
Minimum value:	N.A.	Maximum value:	N.A.	Default value:	0
Options:	0 = Disabled; or 1 = Enabled.				
Description:	This parameter enables the drive to have a fixed switching frequency which is required by some sine filters. The drive no longer automatically adjusts the switching frequency based on the unit temperature.				
P5.1.12^{①②}	Over voltage controller				ID 294
Minimum value:	N.A.	Maximum value:	N.A.	Default value:	3
Options:	0 = Disable over voltage controller; 1 = The maximum controller output frequency is the (ramp frequency + 8 Hz); 2 = The maximum controller output frequency is the maximum frequency; or 3 = The maximum controller output frequency is the (maximum frequency + 8 Hz).				
Description:	The over voltage control is used to limit the DC link voltage below the preset limit value. If over voltage control is enabled, the drive will control the DC link voltage below the preset limit value by increasing the output frequency to allow the motor to use the energy.				
P5.1.13^①	Over voltage controller reference				ID 1874
Minimum value:	DCLinkUnderVolt-ResumeExcursion V	Maximum value:	DCLinkOverVoltBr V	Default value:	0 V
Description:	The over voltage reference defines the preset limit value used in the overvoltage controller.				
P5.1.14^②	Load drooping				ID 298
Minimum value:	0.00%	Maximum value:	100.00%	Default value:	0.00%
Description:	The drooping function enables speed drop as a function of load. This parameter sets that amount corresponding to the nominal torque of the motor.				
P5.1.15^②	Droop control filter time constant				ID 1630
Minimum value:	0 ms	Maximum value:	3,000 ms	Default value:	0 ms
Description:	Filter time when using droop control.				

Appendix C Parameter Descriptions

Motor control (Cont.).

P5.1.16^{①②}	Identification			ID 299
Minimum value:	N.A.	Maximum value:	N.A.	Default value: 0
Options:	0 = Not action. 1 = Identification only stator resistor - does not spin the motor. This can be done with load attached. 2 = Identification with run - motor stator resistor is completed then the motor is run. This must be completed with unloaded motor. 3 = Identification no run - motor is supplied with current and voltage but at zero frequency. 4 = Identification only inertia - identification for the system inertia only.			
Description:	This parameter enables the drive to make an motor identification cycle of the motor once complete the drive will adjust tuning parameters to improve starting torque and open loop vector control performance. Once set and a run command is given, the operation will be active then set back to 0 when completed. When a run command is issued, the message on the keypad will indicate "Auto tuning" is being performed. If there is an issue with the motor identification, a fault message will be displayed.			
P5.1.17^①	Stator resistor			ID 771
Minimum value:	0.001 ohm	Maximum value:	65.535 ohm	Default value: Base on motor.
Description:	Motor stator resistor real value - this value is the stator winding resistance of the windings in the motor. The value is measured when performing identification.			
P5.1.18^①	Rotor resistor			ID 772
Minimum value:	0.001 ohm	Maximum value:	65.535 ohm	Default value: Base on motor.
Description:	Motor rotor resistor real value - this value is the rotor resistance of the motor. The value is measured when performing identification.			
P5.1.19^①	Leak inductance			ID 773
Minimum value:	0.01 mh	Maximum value:	655.35 mh	Default value: Base on motor.
Description:	Motor leakage inductance real value - this value is the amount of magnetic inductance that does not link to a winding in the motor. The value is measured when performing identification.			
P5.1.20^①	Mutual inductance			ID 774
Minimum value:	0.10 mh	Maximum value:	6553.50 mh	Default value: Base on motor.
Description:	Motor mutual inductance real value - this value is the amount of inductance between two sets of windings in the motor. The value is measured when performing identification.			
P5.1.21^①	Excitation current			ID 775
Minimum value:	0.01 A	Maximum value:	655.35 A	Default value: Base on motor.
Description:	Motor no-load current real value - this value is the amount of electrical current required to generate a rotating magnetic field in the motor. The value is measured when performing identification (P5.1.16).			
P5.1.22^①	Motor inertia			ID 1881
Minimum value:	0.000 kgm ²	Maximum value:	65.535 kgm ²	Default value: Base on motor.
Description:	System rotation inertia - real value for speed loop parameter tuning. The value is measured when performing identification.			
P5.1.23^①	PM back electromotive force (BEMF) voltage			ID 1882
Minimum value:	0.0 V	Maximum value:	6553.5 V	Default value: 0.1 V
Description:	Back electromotive force (BEMF) voltage. The value is measured when performing identification.			
P5.1.24^①	PM d-axis stator inductance			ID 1884
Minimum value:	0.00 mh	Maximum value:	655.35 mh	Default value: 0.01 mh
Description:	Voltage across the d-axis stator inductance of the PM motor at the rated motor current and the rated motor frequency displayed in line-to-line rms value. The value is measured when performing identification.			
P5.1.25^①	PM q-axis stator inductance			ID 1883
Minimum value:	0.00 mh	Maximum value:	655.35 mh	Default value: 0.01 mh
Description:	Voltage across the q-axis stator inductance of the PM motor at the rated motor current and the rated motor frequency displayed in line-to-line rms value. The value is measured when performing identification.			
P5.1.26	Slip compensation coefficient			ID 1664
Minimum value:	0%	Maximum value:	500%	Default value: 100%
Description:	The linear coefficient of the slip compensation frequency, which is valid only in the speed control mode.			

Appendix C Parameter Descriptions

Motor control (Cont.).

P5.1.27	<i>VF stable Kd</i>			ID 1656
Minimum value:	0%	Maximum value:	1,000%	Default value: 100%
Description:	The compensation coefficient of the d-axis, which is used to suppress oscillation.			
P5.1.28	<i>VF stable Kq</i>			ID 1657
Minimum value:	0%	Maximum value:	1,000%	Default value: 100%
Description:	The compensation coefficient of the q-axis, which is used to suppress oscillation.			
P5.1.29^{①②}	<i>Over-modulation enable</i>			ID 2835
Minimum value:	N.A.	Maximum value:	N.A.	Default value: 0
Options:	0 = Disabled; or 1 = Enabled.			
Description:	The linear coefficient of the slip compensation frequency, which is valid only in the speed control mode.			
P5.2 - Sensorless Vector Control parameters.				
P5.2.1^②	<i>Speed error filter time constant</i>			ID 1591
Minimum value:	0 ms	Maximum value:	3,000 ms	Default value: 20 ms
Description:	Filter time constant for speed reference and actual speed error.			
P5.2.2	<i>Speed control Kp1</i>			ID 1593
Minimum value:	0.0%	Maximum value:	6,000.0%	Default value: 100.0%
Description:	Sets P-gain of “Vector” control mode when in frequency region 1 for faster speed response.			
P5.2.3	<i>Speed control Tt1</i>			ID 1594
Minimum value:	1 ms	Maximum value:	3,000 ms	Default value: 100 ms
Description:	Sets time constant of “Vector” control mode when in frequency region 1 for faster speed response.			
P5.2.4^②	<i>Speed control FS1</i>			ID 1597
Minimum value:	0.00 Hz	Maximum value:	SPEED_CONTROL_FS2 Hz	Default value: 5.00 Hz
Description:	Sets the “Vector” control mode frequency.			
P5.2.5^②	<i>Speed control FS2</i>			ID 1598
Minimum value:	SPEED_CONTROL_FS1 Hz	Maximum value:	MaxFreq Hz	Default value: 10.00 Hz
Description:	Sets the “Vector” control mode frequency.			
P5.2.6^②	<i>Speed control Kp2</i>			ID 1599
Minimum value:	0.0%	Maximum value:	6,000.0%	Default value: 50.0%
Description:	Sets P-gain of “Vector” control mode when in frequency region two for faster speed response.			
P5.2.7^②	<i>Speed control Tt2</i>			ID 1600
Minimum value:	1 ms	Maximum value:	3,000 ms	Default value: 100 ms
Description:	Sets time constant of “Vector” control mode when in frequency region two for faster speed response.			
P5.2.8^②	<i>Motoring torque limit FWD</i>			ID 1836
Minimum value:	0.0%	Maximum value:	300.0%	Default value: 300.0%
Description:	Motoring torque limit in the forward direction.			
P5.2.9^②	<i>Generator torque limit FWD</i>			ID 1837
Minimum value:	0.0%	Maximum value:	300.0%	Default value: 300.0%
Description:	Generation torque limit in the forward direction.			

Appendix C Parameter Descriptions

Motor control (Cont.).

P5.2.10^②	Motoring torque limit REV			ID 1838
Minimum value:	0.0%	Maximum value:	300.0%	Default value: 300.0%
Description:	Motoring torque limit in the reverse direction.			
P5.2.11^②	Generator torque limit REV			ID 1839
Minimum value:	0.0%	Maximum value:	300.0%	Default value: 300.0%
Description:	Generation torque limit in the reverse direction.			
P5.2.12^②	Motoring power limit			ID 1607
Minimum value:	0.0%	Maximum value:	300.0%	Default value: 300.0%
Description:	Motor power limit setting.			
P5.2.13^②	Generator power limit			ID 1608
Minimum value:	0.0%	Maximum value:	300.0%	Default value: 300.0%
Description:	Generator power limit setting.			
P5.2.14^{①②}	Flux reference			ID 1620
Minimum value:	0.0%	Maximum value:	500.0%	Default value: 100.0%
Description:	This parameter defines the amount of flux that is output to the motor, which is valid only in open loop vector control.			
P5.2.15^①	PM initial selection			ID 1890
Minimum value:	N.S.	Maximum value:	N.A.	Default value: 1
Options:	0 = Align; 1 = Six pulse; or 2 = HFI.			
Description:	PM initial angle detect method.			
P5.2.16^①	PM initial time			ID 1891
Minimum value:	0.0 s	Maximum value:	60.0 s	Default value: 0.7 s
Description:	PM initial angle detect time.			
P5.2.17^①	PM excited current			ID 1892
Minimum value:	0%	Maximum value:	200%	Default value: 20%
Description:	PM excited current during the low speed.			
P5.2.18^①	PM excited current off frequency			ID 1893
Minimum value:	10.00%	Maximum value:	MotorNomFreq %	Default value: 20.00%
Description:	PM excited current cut off frequency.			
P5.2.19	Observer Kp			ID 2901
Minimum value:	1%	Maximum value:	3,000%	Default value: 100%
Description:	Linear gain of the PM/IM observer.			

^① Parameter value can only be changed after the drive has stopped.

^② Parameter value will be set to be default when changing macros.

Protections

P6.1 - Motor.				
P6.1.1^{①②}	Output phase fault			ID 308
Minimum value:	N.A.	Maximum value:	N.A.	Default value: 2
Options:	0 = No response; 1 = Warning; 2 = Fault - stop mode after fault according to parameter stop mode; or 3 = Fault - stop mode after fault always by coasting.			
Description:	Output phase supervision of the motor ensures that the motor phases have equal currents. If phases are 5% difference from one another, the frequency converter will respond corresponding to this setting.			

Appendix C Parameter Descriptions

Protections (Cont.).

P6.1.2^{①②}	Ground fault			ID 309
Minimum value:	N.A.	Maximum value:	N.A.	Default value: 2
Options:	0 = No response; 1 = Warning; 2 = Fault - stop mode after fault according to parameter stop mode; or 3 = Fault - stop mode after fault always by coasting.			
Description:	Earth (ground) fault protection ensures that the sum of the motor phase currents is zero. There is a current level setting parameter ground fault limit that allows for setting the allowable ground current level based off the total drive current. The overcurrent protection is always working and protects the frequency converter from earth faults with high currents. Frequency converter will correspond the setting (see Options above).			
P6.1.3^{①②}	Ground fault limit			ID 2158
Minimum value:	0%	Maximum value:	30%	Default value: 15%
Description:	Sets the level of the ground fault protection. This protection is based off the amount of leakage current that is seen to ground on the output of the drive.			
P6.1.4^{①②}	Motor thermal protection			ID 310
Minimum value:	N.A.	Maximum value:	N.A.	Default value: 2
Options:	0 = No response; 1 = Warning; 2 = Fault - stop mode after fault according to parameter stop mode; or 3 = Fault - stop mode after fault always by coasting.			
Description:	If a fault condition is selected, the drive will stop and activate the fault stage based off the % of calculated motor temperature. The calculated motor temp is based off the install power on values of the drive and monitoring values as the drive is running. Deactivating this protection, i.e., setting parameter to 0, will reset the thermal stage of the motor to 0%.			
P6.1.5^②	Motor thermal FO current			ID 311
Minimum value:	0.00%	Maximum value:	150.00%	Default value: 100.00%
Description:	The current can be set between 0 - 150.0% x InMotor. This parameter sets the value for thermal current at zero frequency. The default value is set assuming that there is no external fan cooling the motor. If an external fan is used, this parameter can be set to 90% (or even higher).			

Note: The value is set as a percentage of the motor nameplate data, P1.6 (nominal current of the motor), not the drive's nominal output current. The motor's nominal current is the current that the motor can withstand in direct on-line use without being overheated. If you change the parameter nominal current of motor, this parameter is automatically restored to the default value. Setting this parameter does not affect the maximum output current of the drive.

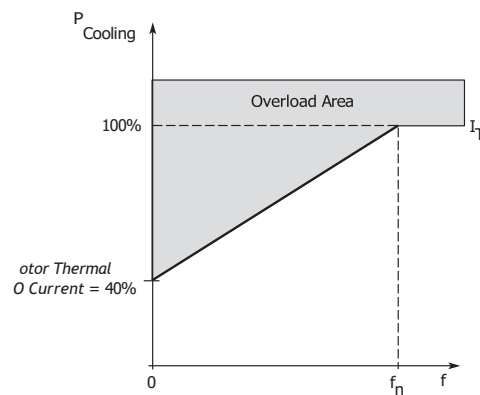

Appendix C Parameter Descriptions

Protections (Cont.).

P6.1.6 ^{①②}	Stall protection			ID 313
Minimum value:	N.A.	Maximum value:	N.A.	Default value: 0
Options:	0 = No action; 1 = Warning; 2 = Fault; or 3 = Fault, coast.			
Description:	Stall protection is a user defined of overcurrent protection. It protects the motor from short time overload situations like a stalled shaft. This is customer selectable based off of current level, frequency level, and time.			

P6.1.7 ^②	Stall current limit			ID 314
Minimum value:	0.10 A	Maximum value:	MotorNomCurr*2 A	Default value: MotorNomCurr*1.3 A
Description:	The current can be set to 0.1-InMotor*2. For a stall stage to occur, the current must have exceeded this limit. The software does not allow entering a greater value than InMotor*2. If P1.6, nominal motor current is changed, this parameter is automatically restored to the default value (IL).			

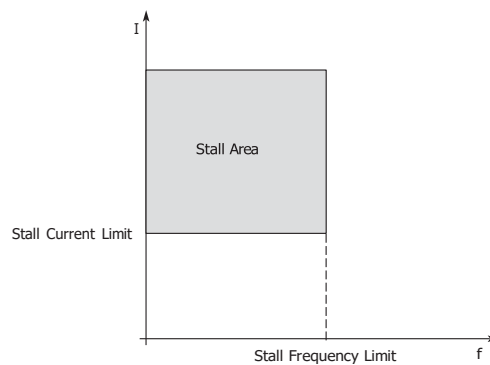

P6.1.8 ^②	Stall time limit			ID 315
Minimum value:	1.0 s	Maximum value:	120.0 s	Default value: 15.0 s
Description:	This time can be set between 1.0 and 120.0s. This is the maximum time allowed for a stall stage. The stall time is counted by an internal up/down counter based off the current being above the limit setting. If the stall time counter value goes above this limit the protection will cause a trip (see P6.1.6).			

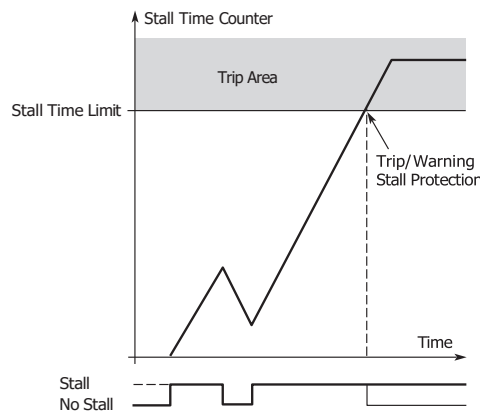

P6.1.9 ^②	Stall frequency limit			ID 316
Minimum value:	1.00 Hz	Maximum value:	MaxFreq Hz	Default value: 25.00 Hz
Description:	The frequency can be set between 1-fmax (P1.2). For a stall state to occur, the output frequency must have remained below this limit, above the current limit for the stall time to occur.			

Appendix C Parameter Descriptions

Protections (Cont.)

P6.1.10^{①②}	Underload protection			ID 317
Minimum value:	N.A.	Maximum value:	N.A.	Default value: 0
Options:	0 = No response; 1 = Warning; 2 = Fault - stop mode after fault according to parameter stop mode; or 3 = Fault - stop mode after fault always by coasting.			
Description:	If fault is set as the function, the drive will stop and activate the fault stage based on the parameter conditions and the monitoring status of the motor. If the motor torque drops below the F_{nom} and F_0 , torque levels for the time limit the protection is enabled. Deactivating the protection by setting the parameter to 0 will reset the underload time counter to zero.			
P6.1.11^{①②}	Underload F_{nom} torque			ID 318
Minimum value:	10.0%	Maximum value:	150.0%	Default value: 50.0%
Description:	The torque limit can be set between 10.0 - 150.0 % T_{nMotor} . This parameter gives the value for the minimum torque allowed when the output frequency is at or above the field weakening point. If you change P1.6, nominal motor current, this parameter is automatically restored to the default value.			
P6.1.12^②	Underload F_0 torque			ID 319
Minimum value:	5.0%	Maximum value:	150.0%	Default value: 10.0%
Description:	The torque limit can be set between 5.00 - 150.00% T_{nMotor} . This parameter gives value for the minimum torque allowed at zero frequency. If you change the value of P1.6, nominal motor current, this parameter is automatically restored to the default value.			

Appendix C Parameter Descriptions

Protections (Cont.)

P6.1.13^②	<i>Underload time limit</i>			ID 320
Minimum value:	2.00 s	Maximum value:	600.00 s	Default value: 20.00 s
Description:	This time can be set between 2.00 and 600.00 seconds. This is the time allowed for an fault state to exist. An internal up/down counter counts the accumulated underload time. If the underload counter value goes above this limit, the protection will cause a trip according to protection parameter. If the drive is stopped, the counter is reset to zero.			

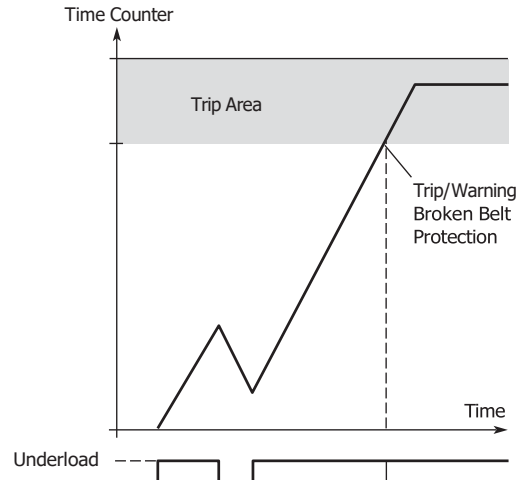

P6.1.14^②	<i>Preheat mode</i>			ID 2159
Minimum value:	N.A.	Maximum value:	N.A.	Default value: 0
Options:	0 = Disable; or 1 = Enable			
Description:	This parameter enables/disables the preheat function where this is used where the temperature being read from the drive will turn on the output to allow current to flow to the motor, this is typically used when the motor is not running.			
P6.1.15^②	<i>Preheat control source</i>			ID 2160
Minimum value:	N.A.	Maximum value:	N.A.	Default value: 1
Options:	0 = DI function; or 1 = Drive temperature.			
Description:	Selects the source of where the temperature is coming from, either digital input or the drive heat sink temperature, which potentially could be at a different temperature.			
P6.1.16^②	<i>Preheat enter temperature</i>			ID 2161
Minimum value:	-10.0°C	Maximum value:	20.0°C	Default value: 10.0°C
Description:	Temperature when the preheat is enabled - drive goes into a run state to all the preheat voltage to flow through the motor an create some current.			
P6.1.17^②	<i>Preheat quit temperature</i>			ID 2162
Minimum value:	-10.0°C	Maximum value:	39.9°C	Default value: 20.0°C
Description:	Temperature when the preheat is disabled - drive goes into a stop state if the temperature is above this rating.			

Appendix C Parameter Descriptions

Protections (Cont.).

P6.2 - Drive.					
P6.2.1^②	Line start lockout				ID 750
Minimum value:	N.A.	Maximum value:	N.A.	Default value:	2
Options:	0 = Respond to I/O run command when power is applied. If in another control place and switched to I/O, control does not respond. (Run command has to be cycled.) 1 = Do not respond to I/O run command when power is applied. If in another control place and switched to I/O, control does not respond. (Run command has to be cycled.) 2 = Respond to I/O commands when power is applied. If in another control place and switched to I/O control, the drive will respond to a maintained run command. 3 = Do not respond to I/O commands when power is applied. If in another control place and switched to I/O control, the drive will respond to a maintained run command.				
Description:	Determines the response of frequency converter going to a run state cycle with I/O run command is still active as the control place.				
P6.2.2^{①②}	Input phase fault				ID 332
Minimum value:	N.A.	Maximum value:	N.A.	Default value:	2
Options:	0 = No response; 1 = Warning; 2 = Fault, stop mode after fault according to parameter stop mode; 3 = Fault, stop mode after fault always by coasting; or 4 = Single phase power limit.				
Description:	The input phase supervision ensures that the input phases of the frequency converter have approximately equal current draw.				
P6.2.3^{①②}	4 mA input fault				ID 306
Minimum value:	N.A.	Maximum value:	N.A.	Default value:	0
Options:	0 = No response; 1 = Warning; 2 = Warning - the frequency from 10 seconds back is set as reference; 3 = Warning - the preset frequency P6.2.4 is set as reference; 4 = Fault - stop mode after fault according to parameter stop mode; or 5 = Fault - stop mode after fault always by coasting.				
Description:	A warning or a fault action and message is generated if the 4 - 20 mA reference signal is used and the signal falls below 4 mA for 5 seconds, or below 0.5 mA for 0.5 seconds. The information can also be programmed into relay outputs RO1 and RO2.				
P6.2.4^{①②}	4 mA fault frequency				ID 331
Minimum value:	0.00 Hz	Maximum value:	MaxFreq Hz	Default value:	0.00 Hz
Description:	When 4 mA fault happens, the output frequency of drive goes to this preset speed when P6.2.3 = 3.				
P6.2.5^{①②}	External fault				ID 307
Minimum value:	N.A.	Maximum value:	N.A.	Default value:	2
Options:	0 = No action; 1 = Warning; 2 = Fault, stop mode after fault according to parameter stop mode; or 3 = Fault, stop mode after fault always by coasting.				
Description:	A warning or a fault action and message is generated from the external fault signal in the programmable (digital inputs function select external fault). The status information can also be programmed into digital output relay outputs RO1 and RO2.				
P6.2.6^{①②}	Undervoltage fault response				ID 330
Minimum value:	N.A.	Maximum value:	N.A.	Default value:	2
Options:	0 = No response; 1 = Warning; 2 = Fault, stop mode after fault according to parameter stop mode; or 3 = Fault, stop mode after fault always by coasting.				
Description:	Frequency converter monitors DC Bus voltage if it drops below set level (via trouble shooting guide for more information on fault level), the drive will respond corresponding to this setting.				

Appendix C Parameter Descriptions

Protections (Cont.).

P6.2.7^{①②}	Unit under temperature protection			ID 1564
Minimum value:	N.A.	Maximum value:	N.A.	Default value: 2
Options:	0 = No action; 1 = Warning; 2 = Fault; or 3 = Fault, coast.			
Description:	This protection sets the response to a low frequency converter temperature on the heat sink.			
P6.2.8^②	Cold weather mode			ID 2126
Minimum value:	N.A.	Maximum value:	N.A.	Default value: 0
Options:	0 = Disabled; or 1 = Enabled.			
Description:	With this parameter, you are able to enable the cold weather function of the causing the frequency converter's under temp limit to drop from -10°C to -30°C. This then enables a warm-up feature when the frequency converter is between -30°C and -20°C. The motor, when given a run command, will turn on for the cold weather time-out and output the cold weather voltage at 0.5 Hz to allow the motor to warm up. If it does not warm up above -20°C, after that the time frequency converter will fault on under temp fault. If the frequency converter does go above -20°C, output will begin to follow reference.			
P6.2.10^②	Cold weather time out			ID 2128
Minimum value:	0 min	Maximum value:	10 min	Default value: 3 min
Description:	With this parameter, you are able to select the time limit that the frequency converter will run in the warm-up period.			
P6.2.11^②	STO fault response			ID 2427
Minimum value:	N.A.	Maximum value:	N.A.	Default value: 2
Options:	0 = No Action - drive will stop, no indication shown, no reset required, have to cycle start command. 1 = Warning - drive indicate warning/if STO clears drive will run without reset. 2 = Fault - drive will indicate fault/require reset to start again.			
Description:	STO fault response defines the function of how the STO input will be seen on the keypad and how the drive functions to it.			
P6.2.12^①	PI feedback AI loss response			ID 2401
Minimum value:	N.A.	Maximum value:	N.A.	Default value: 0
Options:	0 = No action; 1 = Warning; 2 = Fault; or 3 = Warning: preset frequency (P6.2.13).			
Description:	This parameter defines the function of the PI feedback analog input loss response. If the AI feedback is lost based off the programed AI feedback.			
P6.2.13^{①②}	PI feedback AI loss pre-frequency			ID 2402
Minimum value:	0.00 Hz	Maximum value:	400.00 Hz	Default value: 0.00 Hz
Description:	This parameter defines the frequency the master would run to if a feedback is lost and P6.2.12 was set to option 3.			
P6.2.14^②	PI feedback AI loss pipe fill			ID 2403
Minimum value:	0.0 A	Maximum value:	1000.0 A	Default value: 0.0 A
Description:	Detects loss of prime in the pump based off the measured level. If the value drops below this level for the time in P6.2.15 and below, the frequency in P6.2.13 "loss of prime" occurs.			
P6.2.15^②	PI feedback AI loss pre-frequency timeout			ID 2404
Minimum value:	0 s	Maximum value:	6,000 s	Default value: 0 s
Description:	PI feedback AI loss pre-frequency timeout - when P6.2.12 is set to 3 or 4, when the feedback signal is lost, the drive will run at the frequency in P6.2.15 for the time set here. After this time, the drive will fault out on "feedback loss". The time is disabled when set to 0 seconds.			
P6.2.16^{①②}	Overvoltage controller response			ID 1840
Minimum value:	N.A.	Maximum value:	N.A.	Default value: 0
Options:	0 = No action; 1 = Warning (W/O S); or 2 = Warning (W S).			
Description:	Display options for overvoltage controller warning.			

Appendix C Parameter Descriptions

Protections (Cont.).

P6.2.17^{①②}	Overcurrent controller response			ID 1841
Minimum value:	N.A.	Maximum value:	N.A.	Default value: 0
Options:	0 = No action; 1 = Warning (W/O S); or 2 = Warning (W S).			
Description:	Display options for current limit controller warning.			
P6.2.18	Cold weather password			ID 2129
Minimum value:	N.A.	Maximum value:	N.A.	Default value: 0
Description:	This password allows access to override the under temperature fault protection. This parameter is seen by pressing the left and right soft keys on the keypad. Password should be set to 62385. This value gets reset on cycle of power.			
P6.2.19	Under-temperature fault override			ID 2130
Minimum value:	N.A.	Maximum value:	N.A.	Default value: 0
Options:	0 = No; or 1 = Yes.			
Description:	With the password set to the correct value, this parameter is enabled and will give the ability to override the under temp fault. This function gets reset when power is cycled.			
P6.3 - Communications.				
P6.3.1^{①②}	Fieldbus fault response			ID 334
Minimum value:	N.A.	Maximum value:	N.A.	Default value: 2
Options:	0 = No action; 1 = Warning; 2 = Fault; or 3 = Fault, coast.			
Description:	This sets the response mode for the fieldbus fault when a fieldbus mode is used and communication is lost between the PLC and communication port. Each protocol has another parameter to select in all control or only in fieldbus control to set fault or warning.			
P6.3.2^{①②}	OPTcard fault response			ID 335
Minimum value:	N.A.	Maximum value:	N.A.	Default value: 2
Options:	0 = No action; 1 = Warning; 2 = Fault; or 3 = Fault, coast.			
Description:	This sets the response mode for a board slot fault caused by a missing or failed option board not communicating to the central processor.			
P6.3.3^{①②}	IP address conflict response			ID 1678
Minimum value:	N.A.	Maximum value:	N.A.	Default value: 1
Options:	0 = No action; 1 = Warning; 2 = Fault - stop mode after fault according to parameter stop mode; or 3 = Fault - stop mode after fault always by coasting.			
Description:	Indicates there is a conflict in the IP address assigned to the drive, typically meaning there are multiple devices with the same IP address assigned. .			
P6.3.4^{①②}	Keypad communication fault response			ID 2157
Minimum value:	N.A.	Maximum value:	N.A.	Default value: 0
Options:	0 = No action; 1 = Warning; 2 = Fault; or 3 = Fault, coast.			
Description:	This parameter defines the function of the keypad communication response in the case the keypad is removed.			

Appendix C Parameter Descriptions

Protections (Cont.)

P6.4 - Auto restart.				
P6.4.1^②	AR wait time			ID 321
Minimum value:	1.00 s	Maximum value:	300.00 s	Default value: 1.00 s
Description:	Defines the time before the frequency converter tries to automatically restart the motor after a specific fault condition has been clear.			
P6.4.2^②	AR trail time			ID 322
Minimum value:	1.00 s	Maximum value:	600.00 s	Default value: 30.00 s
Description:	<p>Amount of time after fault set that the drive uses the restart attempts to reset the fault and restart the motor, after this time has run out without resetting the alarm drive will fault.</p> <p>P6.4.4 to P6.4.11 determine the maximum number of automatic restarts during the trial time set by P6.4.2. The time count starts from the first auto restart. If the number of faults occurring during the trial time exceeds the values of P6.4.4 to P6.4.11, the fault state becomes active. Otherwise the fault is cleared after the trial time has elapsed and the next fault starts the trial time count again. If a single fault remains during the trial time, a fault state is true.</p>			
	<p style="text-align: center;">Auto Restart Fail (Try Number >2.)</p>			
P6.4.3^②	AR start function			ID 323
Minimum value:	N.A.	Maximum value:	N.A.	Default value: 0
Options:	0 = Flying start from stop frequency; 1 = Start according to parameter stop mode; or 2 = Flying start from maximum frequency.			
Description:	The start function for automatic restart is selected with this parameter. The parameter defines the start mode upon an auto restart condition. Defines the time before the frequency converter tries to automatically restart the motor after a specific fault condition has been clear.			
P6.4.4^②	Undervoltage attempts			ID 324
Minimum value:	0	Maximum value:	10	Default value: 1
Description:	<p>This parameter determines how many automatic restarts can be made during the trial time after an undervoltage trip.</p> <p>0 = No automatic restart. >0 = Number of automatic restarts after undervoltage fault.</p> <p>The fault is reset and the drive is started automatically after the DC-link voltage has returned to the normal level.</p>			
P6.4.5^②	Overvoltage attempts			ID 325
Minimum value:	0	Maximum value:	10	Default value: 1
Description:	<p>This parameter determines how many automatic restarts can be made during the trial time after an overvoltage trip.</p> <p>0 = No automatic restart after overvoltage fault trip. >0 = Number of automatic restarts after overvoltage fault trip.</p> <p>The fault is reset and the drive is started automatically after the DC-link voltage has returned to the normal level.</p>			

Appendix C Parameter Descriptions

Protections (Cont.).

P6.4.6^②	Overcurrent attempts			ID 326
Minimum value:	0	Maximum value:	3	Default value: 1
Description:	This parameter determines how many automatic restarts can be made during the trial time. Note: An IGBT temperature fault, saturation fault, and overcurrent faults are included as part of this fault. 0 = No automatic restart after overcurrent fault trip. >0 = Number of automatic restarts after an overcurrent trip, saturation trip, or IGBT temperature fault.			
P6.4.7^②	4 mA fault attempts			ID 327
Minimum value:	0	Maximum value:	10	Default value: 1
Description:	This parameter determines how many automatic restarts can be made during the trial time. 0 = No automatic restart after reference fault trip. >0 = Number of automatic restarts after the analog current signal (4-20 mA) has returned to the normal level (>4 mA).			
P6.4.8^②	Motor temperature fault attempts			ID 329
Minimum value:	0	Maximum value:	10	Default value: 1
Description:	This parameter determines how many automatic restarts can be made during the trial time. 0 = No automatic restart after Motor temperature fault trip. >0 = Number of automatic restarts after the motor temperature has returned to its normal level.			
P6.4.9^②	External fault attempts			ID 328
Minimum value:	0	Maximum value:	10	Default value: 0
Description:	This parameter determines how many automatic restarts can be made during the trial time. 0 = No automatic restart after external fault trip. >0 = Number of automatic restarts after external fault trip.			
P6.4.10^②	Underload attempts			ID 336
Minimum value:	0	Maximum value:	10	Default value: 1
Description:	This parameter determines how many automatic restarts can be made during the trial time. 0 = No automatic restart after an underload fault trip. >0 = Number of automatic restarts after an underload fault trip.			
P6.4.11^②	PI feedback AI loss attempts			ID 2405
Minimum value:	0	Maximum value:	10	Default value: 1
Description:	This parameter sets the amount of tries it will try to auto restart the feedback AI loss fault.			

① Parameter value can only be changed after the drive has stopped.

② Parameter value will be set to be default when changing macros.

PI Controller

P7.1 - Basic settings.				
P7.1.1^②	PI control gain			ID 1294
Minimum value:	0.00%	Maximum value:	200.00%	Default value: 100.00%
Description:	Defines the gain of the PI Controller. It adjust the slope of the speed increase according to the initial of the load. If this value is set to 100%, a change of 10% in the error value causes the controller output to change 10%.			
P7.1.2^②	PI control time			ID 1295
Minimum value:	0.00 s	Maximum value:	600.00 s	Default value: 1.00 s
Description:	Defines the integration time of the PI controller. Over the time, the integral time contributes to the deviation between the reference and the feedback signal. If this value is set to 1.00 sec., a change of 10% in the error value causes the controller output to change by 10.00%/s.			

Appendix C Parameter Descriptions

PI Controller (Cont.).

P7.1.3^{①②}	PI process unit			ID 1297
Minimum value:	N.A.	Maximum value:	N.A.	Default value: 0
Options:	0 = %; 1 = 1/min.; 2 = rpm; 3 = ppm; 4 = pps; 5 = l/s; 6 = l/min.; 7 = l/h; 8 = kg/s; 9 = kg/min.; 10 = kg/h; 11 = m ³ /s; 12 = m ³ /min.; 13 = m ³ /h; 14 = m/s; 15 = mbar; 16 = bar; 17 = Pa; 18 = kPa; 19 = mV/s; 20 = kW; 21 = Deg. C; 22 = GPM; 23 = gal/s; 24 = gal/min.; 25 = gal/h; 26 = lb/s; 27 = lb/min.; 28 = lb/h; 29 = CFM; 30 = ft ³ /s; 31 = ft ³ /min.; 32 = ft ³ /h; 33 = ft/s; 34 = in. wg; 35 = ft wg; 36 = PSI; 37 = lb/in. ² ; 38 = HP; 39 = Deg. F; 40 = PA; 41 = WC; 42 = HG; 43 = ft; or 44 = m.			
Description:	Defines the unit type for PI feedback unit.			
P7.1.4^②	PI process unit minimum			ID 1298
Minimum value:	-99999.99 varies	Maximum value:	PI Process Unit Max varies	Default value: 0.00 varies
Description:	Defines the minimum process unit value.			
P7.1.5^②	PI process unit maximum			ID 1300
Minimum value:	PI Process Unit Min varies	Maximum value:	99999.99 varies	Default value: 100.00 varies
Description:	Defines the maximum process unit value.			
P7.1.6^{①②}	PI error inversion			ID 1303
Minimum value:	N.A.	Maximum value:	N.A.	Default value: 0
Options:	0 = Normal - if feedback is less than set-point, PI controller output increases. 1 = Inverted - if feedback is less than set-point, PI controller output decreases.			
Description:	Defines the way the process value output reacts to the feedback signal.			

Appendix C Parameter Descriptions

PI Controller (Cont.).

P7.1.7^②	PI dead band			ID 1304
Minimum value:	-99999.99 varies	Maximum value:	99999.99 varies	Default value: 0 varies
Description:	PI dead band around setpoint in process units. This is the band where no actions occur to prevent oscillation or repeated activation/deactivation of controller. The PI output is locked if the feedback stays within the dead band area.			
P7.1.8^②	PI dead band delay			ID 1306
Minimum value:	0.00 s	Maximum value:	320.00 s	Default value: 0.00 s
Description:	If the PI process value goes out of the dead band area for the desired time delay, at that point the controller will re-initialize and try to level out again.			
P7.1.9^②	PI ramp time			ID 1311
Minimum value:	0.00 s	Maximum value:	300.00 s	Default value: 0.00 s
Description:	Defines the rising and falling ramp times for changes in the process value.			

① Parameter value can only be changed after the drive has stopped.

② Parameter value will be set to be default when changing macros.

Setpoint

P7.2.1 - Standard.				
P7.2.1.1^②	PI keypad setpoint 1			ID 1307
Minimum value:	PI Process Unit Min varies	Maximum value:	PI Process Unit Max varies	Default value: 0.00 varies
Description:	Keypad PI reference value setpoint 1.			
P7.2.1.2^②	PI keypad setpoint 2			ID 1309
Minimum value:	PI Process Unit Min varies	Maximum value:	PI Process Unit Max varies	Default value: 0.00 varies
Description:	Keypad PI reference value setpoint 2.			
P7.2.1.3^②	PI wake-up action			ID 2466
Minimum value:	N.A.	Maximum value:	N.A.	Default value: 0
Options:	0 = Wake-up when below wake-up level. 1 = Wake-up when above wake-up level. 2 = Wake-up when below wake-up level % from PI setpoint. 3 = Wake-up when above wake-up level % from PI setpoint.			
Description:	This parameter defines the wake-up function action.			
P7.2.2 - Setpoint 1.				
P7.2.2.1^①	PI setpoint 1 source			ID 1312
Minimum value:	N.A.	Maximum value:	N.A.	Default value: 1
Options:	0 = Not used; 1 = PI keypad setpoint 1; 2 = PI keypad setpoint 2; 3 = AI; 4 = Drive reference pot; 5 = FB process data input 1; 6 = FB process data input 2; 7 = FB process data input 3; 8 = FB process data input 4; 9 = FB process data input 5; 10 = FB process data input 6; 11 = FB process data input 7; 12 = FB process data input 8; 13 = FB PI setpoint 1; or 14 = FB PI setpoint 2.			
Description:	Defines source of the setpoint value the drive uses. This can either be an internal preset value, keypad setpoint, analog signal, or fieldbus message.			

Appendix C Parameter Descriptions

Setpoint (Cont.).

P7.2.2.2 ^①	PI setpoint 1 sleep enable			ID 1315
Minimum value:	N.A.	Maximum value:	N.A.	Default value: 0
Options:	0 = Disabled; or 1 = Enabled.			
Description:	This function will disable the output when the frequency drops below the sleep frequency for the sleep delay time. The output re-engages when feedback rises above the wake-up level.			
P7.2.2.3 ^②	PI setpoint 1 sleep delay			ID 1317
Minimum value:	0 s	Maximum value:	3,000 s	Default value: 0 s
Description:	This parameter sets the delay time after the setpoint drops below the sleep level for this amount of time and then the drives output will shut off till the wake up level is met. It is to prevent large fluctuations when going into the sleep function to save motor run time.			
P7.2.2.4 ^②	PI setpoint 1 wake-up level			ID 1318
Minimum value:	-99999.99 varies	Maximum value:	99999.99 varies	Default value: 0.00 varies
Description:	Defines the level for the PI feedback value to go above top enable the PI output to be re enabled. This value is based of the % of feedback which can be scaled based off the PI unit min./max, values.			
P7.2.2.5 ^②	PI setpoint 1 boost			ID 1320
Minimum value:	-2.00 varies	Maximum value:	2.00 varies	Default value: 1.00 varies
Description:	The setpoint can be boosted via a multiplier value.			
P7.2.2.6 ^②	PI setpoint 1 sleep level			ID 2450
Minimum value:	MinFreq Hz	Maximum value:	MaxFreq Hz	Default value: 0.00 Hz
Description:	Defines the level of which the unit value is used to look at to go into the sleep mode. When the unit drops below this level for the sleep delay time, it will put the drive into the sleep mode.			
P7.2.2.7 ^②	SPI sleep mode over cycle time			ID 1842
Minimum value:	0	Maximum value:	10	Default value: 0
Description:	Defines the count the drive come in and out of sleep mode. If multiple times done in this time frame, the drive would trip on "pump over cycle" fault. One cycle is defined when the drive transfers from normal mode to sleep mode. 0 value means do not do the sleep over cycle check and clear "pump over cycle" fault.			
P7.2.2.8 ^②	SPI sleep mode maximum cycle time			ID 1843
Minimum value:	0 s	Maximum value:	3,600 s	Default value: 300 s
Description:	Defines the maximum time for sleep over cycle checking.			
P7.2.3 - Setpoint 2.				
P7.2.3.1 ^①	PI setpoint 2 source			ID 1321
Minimum value:	N.A.	Maximum value:	N.A.	Default value: 1
Options:	0 = Not used; 1 = PI keypad setpoint 1; 2 = PI keypad setpoint 2; 3 = AI; 4 = Drive reference pot; 5 = FB process data input 1; 6 = FB process data input 2; 7 = FB process data input 3; 8 = FB process data input 4; 9 = FB process data input 5; 10 = FB process data input 6; 11 = FB process data input 7; 12 = FB process data input 8; 13 = FB PI setpoint 1; or 14 = FB PI setpoint 2.			
Description:	Defines source of the setpoint value the drive uses. This can either be an internal preset value, keypad setpoint, analog signal, or fieldbus message.			

Appendix C Parameter Descriptions

Setpoint (Cont.).

P7.2.3.2^①	PI setpoint 2 sleep enable			ID 1324
Minimum value:	N.A.	Maximum value:	N.A.	Default value: 0
Options:	0 = Disabled; or 1 = Enabled.			
Description:	This function will disable the output when the frequency drops below the sleep frequency for the sleep delay time. The output re-engages when feedback rises above the wake-up level.			
P7.2.3.3^②	PI setpoint 2 sleep delay			ID 1326
Minimum value:	0 s	Maximum value:	3,000 s	Default value: 0 s
Description:	This parameter sets the delay time after the setpoint drops below the sleep level for this amount of time and then the drives output will shut off till the wake up level is met. It is to prevent large fluctuations when going into the sleep function to save motor run time.			
P7.2.3.4^②	PI setpoint 2 wake-up level			ID 1327
Minimum value:	-99999.99 varies	Maximum value:	99999.99 varies	Default value: 0.00 varies
Description:	Defines the level for the PI feedback value to go above top enable the PI output to be re enabled. This value is based of the % of feedback which can be scaled based off the PI unit min./max, values.			
P7.2.3.5^②	PI setpoint 2 boost			ID 1329
Minimum value:	-2.00 varies	Maximum value:	2.00 varies	Default value: 1.00 varies
Description:	The setpoint can be boosted via a multiplier value.			
P7.2.3.6^②	PI setpoint 2 sleep level			ID 2452
Minimum value:	MinFreq Hz	Maximum value:	MaxFreq Hz	Default value: 0.00 Hz
Description:	Defines the level of which the unit value is used to look at to go into the sleep mode. When the unit drops below this level for the sleep delay time, it will put the drive into the sleep mode.			
P7.2.3.7^②	SP2 sleep mode over cycle time			ID 1844
Minimum value:	0	Maximum value:	10	Default value: 0
Description:	Defines the count the drive come in and out of sleep mode. If multiple times done in this time frame, the drive would trip on "pump over cycle" fault. One cycle is defined when the drive transfers from normal mode to sleep mode. 0 value means do not do the sleep over cycle check and clear "pump over cycle" fault.			
P7.2.3.8^②	SP2 sleep mode maximum cycle time			ID 1845
Minimum value:	0 s	Maximum value:	3,600 s	Default value: 300 s
Description:	Defines the maximum time for sleep over cycle checking.			

^① Parameter value can only be changed after the drive has stopped.

^② Parameter value will be set to be default when changing macros.

Appendix C Parameter Descriptions

Feedback

P7.3.1 - Standard.				
P7.3.1.1 ^②	<i>PI feedback gain</i>			ID 1331
Minimum value:	-1,000.0%	Maximum value:	1,000.0%	Default value: 100.0%
Description:	Defines gain associated with the feedback signal from the measuring device.			
P7.3.2 - Feedback 1.				
P7.3.2.1 ^①	<i>PI feedback 1 source</i>			ID 1332
Minimum value:	N.A.	Maximum value:	N.A.	Default value: 2
Options:	0 = Not used; 1 = AI; 2 = Drive reference pot; 3 = FB process data input 1; 4 = FB Process Data Input 2; 5 = FB Process Data Input 3; 6 = FB Process Data Input 4; 7 = FB Process Data Input 5; 8 = FB Process Data Input 6; 9 = FB Process Data Input 7; 10 = FB Process Data Input 8; or 11 = FB PI feedback.			
Description:	Defines where feedback signal is being fed into the drive, via analog or fieldbus data value.			
P7.3.2.2 ^②	<i>PI feedback 1 minimum</i>			ID 1333
Minimum value:	-200.00 %	Maximum value:	200.00%	Default value: 0.00%
Description:	Minimum unit value for the feedback signal.			
P7.3.2.3 ^②	<i>PI feedback 1 maximim</i>			ID 1334
Minimum value:	-200.00 %	Maximum value:	200.00%	Default value: 100.00%
Description:	Maximum unit value for the feedback signal.			

① Parameter value can only be changed after the drive has stopped.

② Parameter value will be set to be default when changing macros.

HVAC parameters

P8.1 - Damper (*EVM PRO)				
P8.1.1 ^{①②}	<i>Damper start</i>			ID 483
Minimum value:	N.A.	Maximum value:	N.A.	Default value: 0
Options:	0 = Start - standard start. 1 = Interlocked start: To use this, a relay output, RO1/RO2, needs to be programmed for selections 29 "Damper Control" and a digital input function must be programmed for selection "RunEnable". The relay output is used to energize an element of the driven system, such as a damper, seal water solenoid, or a pre-lube pump. Upon a return acknowledgement of contact closure to the programmed digital input, the frequency converter will start. 2 = Interlock time start: This functions the same as the interlocked start, except that if the return acknowledgement contact is not received within the interlock timeout, a "prevent-up start" fault is displayed in keypad and the start sequence will need to be restarted. 3 = Delay start: This start is similar to the interlocked start, except that a return contact is not used. After the "Delay Time" following the relay output closure, the frequency converter starts.			
Description:	This parameter determines the function of the damper.			
P8.1.2 ^{①②}	<i>Damper time out</i>			ID 484
Minimum value:	1 s	Maximum value:	32,500 s	Default value: 5 s
Description:	The time out time used for an interlocked time start, after which the start sequence must be restarted if no acknowledgement contact is received.			
P8.1.3 ^{①②}	<i>Damper delay</i>			ID 485
Minimum value:	1 s	Maximum value:	32,500 s	Default value: 5 s
Description:	The delay time following a delay start, after which the frequency converter will be started.			

Appendix C Parameter Descriptions

HVAC parameters (Cont.).

P8.2 - Fire mode (*EVM PRO).					
P8.2.1 ^{①②}	Fire mode protection				ID 535
Minimum value:	N.A.	Maximum value:	N.A.	Default value:	0
Options:	0 = Closing contact initiates fire mode function. 1 = Opening contact initiates fire mode function.				
Description:	This parameter determines whether the fire mode function is determined by a contact closure or contact opening on the desired digital input function select fire mode. Note: When fire mode is enabled, this causes the drive to ignore any fault and run till its death. Warranty will be non-valid in the case this is enabled and the drive causes issues to the system.				
P8.2.2 ^{①②}	Fire mode reference select function				ID 536
Minimum value:	N.A.	Maximum value:	N.A.	Default value:	0
Options:	0 = Fire mode minimum frequency; 1 = Fire mode reference; 2 = Fieldbus reference - reference from fieldbus process in; 3 = AI; or 4 = PI1 control - follows the PI control algorithm settings.				
Description:	This parameter allows for setting the reference location for when the fire mode is enabled.				
P8.2.3 ^②	Fire mode minimum frequency				ID 537
Minimum value:	MinFreq Hz	Maximum value:	MaxFreq Hz	Default value:	15.00
Description:	This parameter sets the minimum output frequency for fire mode. This can be used as a selection for reference command.				
P8.2.4 ^②	Fire mode frequency reference 1				ID 565
Minimum value:	0.0%	Maximum value:	100.0%	Default value:	75.0%
Description:	This parameter sets the drive operating percentage based off the 0% being minimum frequency (P1.1) and 100% being maximum frequency (P1.2) for fire mode reference 1.				
P8.2.5 ^②	Fire mode frequency reference 2				ID 564
Minimum value:	0.0%	Maximum value:	100.0%	Default value:	100.0%
Description:	This parameter sets the drive operating percentage based off the 0% being minimum frequency (P1.1) and 100% being maximum frequency (P1.2) for fire mode reference 2.				
P8.2.6	Fire mode test enable				ID 2443
Minimum value:	N.A.	Maximum value:	N.A.	Default value:	N.A.
Options:	0 = Disabled; or 1 = Enabled.				
Description:	This parameter allows for testing the fire mode feature. With the parameter set to enable and fire mode input enabled, the drive will run at the fire mode speed desired but all faults are enabled.				
P8.2.7 ^{①②}	Smoke purge frequency				ID 554
Minimum value:	0.0%	Maximum value:	100.0%	Default value:	50.0%
Description:	Frequency setting for smoke purge. Preset speed used for a digital input selection. The percentage is based off the 0% being minimum frequency (P1.1) and 100% being maximum frequency (P1.2).				
P8.3 - Protections (*EVM PRO).					
P8.3.1 ^{①②}	Broken belt protection				ID 317
Minimum value:	N.A.	Maximum value:	N.A.	Default value:	0
Options:	0 = No action; 1 = Warning; 2 = Fault - stop mode after fault according to parameter stop mode; or 3 = Fault - stop mode after fault always by coasting.				
Description:	If fault is set as the function, the drive will stop and activate the fault stage based on the parameter conditions and the monitoring status of the motor. If the motor torque drops below the Fnom and F0 torque levels for the time limit, the protection is enabled. Deactivating the protection by setting the parameter to 0 will reset the underload time counter to zero.				

Appendix C Parameter Descriptions

HVAC parameters (Cont.).

P8.3.2 ^②	<i>Broken belt Fnom torque</i>			ID 318
Minimum value:	10.0%	Maximum value:	150.0%	Default value: 50.0%
Description:	The torque limit can be set between 10.0-150.0 % x TnMotor. This parameter gives the value for the minimum torque allowed when the output frequency is at or above the field weakening point. If you change P1.6, nominal motor current, this parameter is automatically restored to the default value.			

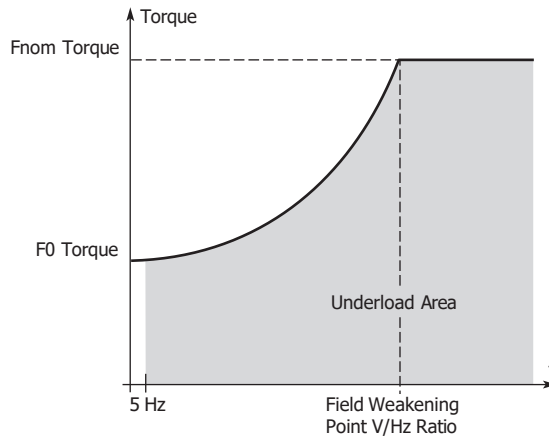

P8.3.3 ^②	<i>Broken belt F0 torque</i>			ID 319
Minimum value:	5.0%	Maximum value:	150.0%	Default value: 10.0%
Description:	The torque limit can be set between 5.0-150.0 % x TnMotor. This parameter gives the value for the minimum torque allowed at zero frequency. If you change the value of P1.6, nominal motor current, this parameter is automatically restored to the default value.			
P8.3.4 ^②	<i>Broken belt time limit</i>			ID 320
Minimum value:	2.00 s	Maximum value:	600.00 s	Default value: 20.00 s
Description:	This time can be set between 2.00 and 600.00 seconds. This is the time allowed for a fault state to exist. An internal up/down counter counts the accumulated underload time. If the underload counter value goes above this limit, the protection will cause a trip according to protection parameter. If the drive is stopped, the counter is reset to zero.			

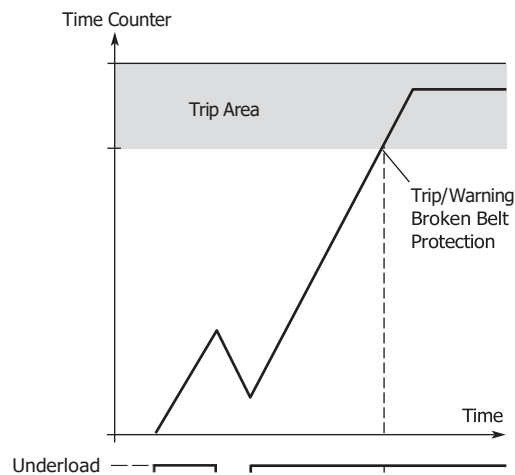

^① Parameter value can only be changed after the drive has stopped.
^② Parameter value will be set to be default when changing macros.

Appendix C Parameter Descriptions

Pump parameters

P9.1 - Derag (*EVM PRO).

P9.1.1^②	Derag cycles			ID 2468
Minimum value:	0	Maximum value:	10	Default value: 3
Description:	This parameter defines the number of cycles in the forward/reverse direction for removing any debris in system.			
P9.1.2^②	Derag at Start/Stop			ID 2469
Minimum value:	N.A.	Maximum value:	N.A.	Default value: 0
Options:	0 = Off; 1 = Start; 2 = Stop; 3 = Start and stop; 4 = Digital input; or 5 = Current.			
Description:	Defines how the derage function will become activated; start, stop, both, or based off the digital input.			
P9.1.3^②	Deragging run time			ID 2470
Minimum value:	1 s	Maximum value:	3,600 s	Default value: 0 s
Description:	Defines the length of time the drive will run at the derag speed in the forward and reverse direction.			
P9.1.4^②	Derag speed			ID 2471
Minimum value:	MinFreq Hz	Maximum value:	MaxFreq Hz	Default value: 5.00 Hz
Description:	Defines the frequency the drive will run at in the forward/reverse direction when in the derag mode.			
P9.1.5^②	Derag off delay			ID 2472
Minimum value:	1 s	Maximum value:	600 s	Default value: 10 s
Description:	Defines the length of time the drive will run the derag function when enabled at stop.			
P9.1.6^{①②}	Derag current			ID 1879
Minimum value:	N.A. A	Maximum value:	N.A. A	Default value: 0.00 A

P9.2 - Start/stop timing (*EVM PRO).

P9.2.1^{①②}	Valve start			ID 1847
Minimum value:	N.A.	Maximum value:	N.A.	Default value: 0
Options:	0 = Normal; 1 = Damper start; 2 = Damper tout; 3 = Damper delay.			
Description:	This parameter determines the function of damper.			
P9.2.2^{①②}	Valve timeout			ID 1848
Minimum value:	1 s	Maximum value:	32,500 s	Default value: 5 s
Description:	The timeout time used for an interlocked time start, after which the start sequence must be restarted if no acknowledgement contact is received.			
P9.2.3^{①②}	Valve delay			ID 1849
Minimum value:	1 s	Maximum value:	32,500 s	Default value: 5 s
Description:	The delay time following a delay start, after which the frequency converter will be started.			

Appendix C Parameter Descriptions

Pump parameters (Cont.).

P9.2.4 ^{①②}	<i>Back spin delay</i>			ID 2423
Minimum value:	0 s	Maximum value:	32,500 s	Default value: 0 s
Description:	Run delay time parameter sets the time required for the drive to wait before another run command can be received. During this time, the run signal is given. It is ignored until the time has expired upon which it will then start. This is true for keypad, I/O, or Fieldbus Control places.			
P9.2.5 ^{①②}	<i>Minimum run time</i>			ID 1813
Minimum value:	0 s	Maximum value:	32,500 s	Default value: 0 s
Description:	Drive minimum run time.			
P9.2.6 ^②	<i>Minimum frequency ramp time</i>			ID 1850
Minimum value:	0.1 s	Maximum value:	2,000.0 s	Default value: 10.0 s
Description:	Ramp time for output to minimum frequency.			
P9.3 - Multi-pump multi-drive (*EVM PRO).				
P9.3.1 ^{①②}	<i>Multi-pump mode</i>			ID 2279
Minimum value:	N.A.	Maximum value:	N.A.	Default value: 0
Options:	0 = Disabled or 1 = Multi-drive network.			
Description:	Determines the number of drives being used in the multi-pump configuration: 0 = Disabled - single drive for motor; or 1 = Multi-drive - multi-follower sequence with multiple drives.			
P9.3.2 ^{①②}	<i>Number of drives</i>			ID 2449
Minimum value:	1	Maximum value:	5	Default value: 1
Description:	This defines the number of drives active when doing the multi-drive pump and fan scheme. By default, there will be always one drive active at one time. By setting value to above one, it allows for bringing in additional drives to maintain the system.			
P9.3.3 ^{①②}	<i>Drive ID</i>			ID 2278
Minimum value:	0	Maximum value:	5	Default value: 0
Description:	This parameter defines the drive address when using multi-drive pump mode. Based off this ID, the drive enables in the desired sequence and can be monitored at this drive ID value in the monitor screen.			
P9.3.4 ^{①②}	<i>Regulation source</i>			ID 2284
Minimum value:	N.A.	Maximum value:	N.A.	Default value: 0
Options:	0 = Network only; or 1 = PI controller.			
Description:	For drives that have been connected with both start/stop signal and PI feedback - can be set up as "Feedback", so they will have ability to be the master.			
P9.3.5 ^②	<i>PI bandwidth</i>			ID 2458
Minimum value:	0.00 varies	Maximum value:	6,000.00 varies	Default value: 10.00 varies
Description:	Percentage based off the setpoint above and below which defines when the auxiliary motor will come online or offline.			
P9.3.6 ^{①②}	<i>Staging frequency</i>			ID 2315
Minimum value:	MinFreq Hz	Maximum value:	400.00 Hz	Default value: 50.00 Hz
Description:	Output frequency is above staging frequency and PI error is out of PI bandwidth - motor should add to system.			
P9.3.7 ^{①②}	<i>De-staging frequency</i>			ID 2316
Minimum value:	0.00 Hz	Maximum value:	MaxFreq Hz	Default value: 0.00 Hz
Description:	Output frequency is below de-staging frequency and PI error is out of PI bandwidth - motor should remove from system.			
P9.3.8 ^②	<i>Add/remove delay</i>			ID 344
Minimum value:	0 s	Maximum value:	3,600 s	Default value: 10 s
Description:	With feedback outside the bandwidth, this time must pass before motors/pumps are added or removed from the system.			

Appendix C Parameter Descriptions

Pump parameters (Cont.).

P9.3.9^②	Interlock enabled			ID 350
Minimum value:	N.A.	Maximum value:	N.A.	Default value: 0
Options:	0 = Disabled; or 1 = Enabled.			
Description:	This parameter enables the drive to look at the digital input interlocks to tell which motor is available for running or if they were brought offline.			
P9.3.10^{①②}	Recovery method			ID 2285
Minimum value:	N.A.	Maximum value:	N.A.	Default value: 0
Options:	0 = Automatic; or 1 = Stop.			
Description:	This parameter is for the slave when multi-drive system lost the master. The slave drive can continue run if it set to be "Automatic". However, the slave drive will stop immediately if it is set to be "Stop".			
P9.3.11^②	Add/remove drive selection			ID 2311
Minimum value:	N.A.	Maximum value:	N.A.	Default value: 0
Options:	0 = Drive ID; or 1 = Run time.			
Description:	In default, MPFC system will add/remove pump according to their drive ID, from small to large. The order can also depend on each slave drive's running time: add the drive that has shortest running time and remove the drive that has longest running time first.			
P9.3.12^②	Run time enabled			ID 2280
Minimum value:	N.A.	Maximum value:	N.A.	Default value: 0
Options:	0 = Disabled; or 1 = Enabled.			
Description:	The run time counter will start counting only if this parameter is enabled.			
P9.3.13^②	Run time limit			ID 2281
Minimum value:	0.0 h	Maximum value:	300,000.0 h	Default value: 0.0 h
Description:	If drive run time is over this limit, its network status will be "Need Alternation". Limit equals 0 means run time counter disabled.			
P9.3.14	Run time reset			ID 2283
Minimum value:	N.A.	Maximum value:	N.A.	Default value: N.A.
Options:	0 = No action; or 1 = Reset.			
Description:	One-time parameter, set to be 1 will clear run time counter.			
P9.3.15^②	Master drive mode			ID 2473
Minimum value:	N.A.	Maximum value:	N.A.	Default value: 0
Options:	0 = Follow PI; 1 = Fixed speed; or 2 = Turn off.			
Description:	Defines how the master drive will maintain the frequency control when slaves are brought in; follow PI, fixed speed, or turn off.			
P9.3.16^②	Master fixed speed			ID 2474
Minimum value:	MinFreq Hz	Maximum value:	MaxFreq Hz	Default value: 50.00 Hz
Description:	Defines the fixed speed frequency when the master drive mode is set for fixed speed control when slaves are brought in.			
P9.3.17^②	Master fixed speed delay			ID 2475
Minimum value:	0 s	Maximum value:	1,000 s	Default value: 5 s
Description:	Defines the delay time before the master drive begins running at the fixed speed or turns off if the master mode is set for fixed speed or turn off.			

Appendix C Parameter Descriptions

Pump parameters (Cont.).

P9.4 - Pipe fill (Loss of prime) (*EVM PRO).					
P9.4.1 ^{①②}	Pipe fill loss response				ID 2410
Minimum value:	N.A.	Maximum value:	N.A.	Default value:	0
Options:	0 = No action; 1 = Warning; 2 = Fault; or 3 = Fault, coast.				
Description:	Defines the response method when a "loss of prime" condition occurs.				
P9.4.2 ^{①②}	Pipe fill loss detection method				ID 2406
Minimum value:	N.A.	Maximum value:	N.A.	Default value:	0
Options:	0 = Motor current; 1 = Motor power (%); or 2 = Motor torque (%).				
Description:	Defines the value for looking at a loss of prime.				
P9.4.3 ^②	Pipe fill loss low level				ID 2407
Minimum value:	0.00 A	Maximum value:	1,000.00 A	Default value:	0.00 A
Description:	If the monitor value is less than low level value and the output frequency is more than low frequency, check the pipe fill loss start.				
P9.4.4 ^{①②}	Pipe fill loss low frequency				ID 2409
Minimum value:	0.00 Hz	Maximum value:	MaxFreq Hz	Default value:	0.00 Hz
Description:	Defines the frequency point at which the drive needs to be above to enable the "loss of prime" feature. When set to 0 Hz, protection is disabled.				
P9.4.5 ^②	Pipe fill loss high level				ID 1851
Minimum value:	0.0 A	Maximum value:	1,000.0 A	Default value:	0.0 A
Description:	If the monitor value is more than high level (the high level is not 0) and the output frequency is more than high frequency, check pipe fill loss start.				
P9.4.6 ^{①②}	Pipe fill loss high frequency				ID 1852
Minimum value:	0.00 Hz	Maximum value:	MaxFreq Hz	Default value:	0.00 Hz
Description:	Defines high frequency point at which the drive needs to be above to enabled the "loss of prime" feature. When set to 0 Hz, protection is disabled.				
P9.4.7 ^②	Pipe fill loss time				ID 2408
Minimum value:	0 s	Maximum value:	600 s	Default value:	0 s
Description:	Defines the delay time before a "loss of prime" condition will occur based of the detection method and prime loss level.				
P9.4.8 ^②	Pipe fill loss attempts				ID 2411
Minimum value:	0	Maximum value:	10	Default value:	1
Description:	Defines the amount of attempts to auto restart the drive on a "prime loss" condition.				
P9.5 - Prime pump (*EVM PRO).					
P9.5.1 ^②	Prime pump enable				ID 2428
Minimum value:	N.A.	Maximum value:	N.A.	Default value:	0
Options:	0 = Disabled; or 1 = Enabled.				
Description:	Prime pump enable.				

Appendix C Parameter Descriptions

Pump parameters (Cont.).

P9.5.2^②	Prime pump level			ID 2429
Minimum value:	0.00 %	Maximum value:	6,000.00 %	Default value: 0.00 %
Description:	This defines the level at which the prime pump function will drop out. If the feedback level raises above this value, prime pump becomes deactivated. If the level is not reached, it will switch after the delay time.			
P9.5.3^②	Prime pump frequency			ID 2431
Minimum value:	MinFreq Hz	Maximum value:	MaxFreq Hz	Default value: 0.00 Hz
Description:	Frequency at which the prime pump function will operate when enabled.			
P9.5.4^②	Prime pump delay time			ID 2432
Minimum value:	0 min.	Maximum value:	3,600 min.	Default value: 0 min.
Description:	This is the time that the drive will run the pre-charge function on start up.			
P9.5.5^②	Prime pump loss of prime level			ID 2433
Minimum value:	0.00 A	Maximum value:	1,000.00 A	Default value: 0.00 A
Description:	Selects the limit to indicate a loss of prime in pump. If the measured current drops below the determined value for the value assigned in the prime loss of time setting, the drive will display "pipe fill loss".			
P9.5.6^②	Prime pump level 2			ID 2434
Minimum value:	0.00 v%	Maximum value:	6,000.00 %	Default value: 0.00 %
Description:	This defines the level at which the prime pump function will drop out. If the feedback level raises above this value, prime pump becomes deactivated. If the level is not reached, it will switch after the delay time.			
P9.5.7^②	Prime pump frequency 2			ID 2436
Minimum value:	MinFreq Hz	Maximum value:	MaxFreq Hz	Default value: 0.00 Hz
Description:	Frequency at which the prime pump level 2 will operate at when enabled.			
P9.5.8^②	Prime pump delay time 2			ID 2437
Minimum value:	0.0 min	Maximum value:	3,600.0 min	Default value: 0.0 min
Description:	This is the time that the drive will run at the 2nd level prime pump function level.			
P9.5.9^②	Prime pump loss of prime level 2			ID 2438
Minimum value:	0.00 A	Maximum value:	1,000.00 A	Default value: 0.00 A
Description:	Selects the limit to indicate a loss of prime in pump. If the measured current drops below the determined value for the value assigned in the prime loss of time setting, the drive will display pipe fill loss.			
P9.6 - Broken pipe (*EVM PRO).				
P9.6.1^{①②}	Broken pipe fault response			ID 1853
Minimum value:	N.A.	Maximum value:	N.A.	Default value: 0
Options:	0 = No action; 1 = Warning; 2 = Fault, coast; or 3 = Fault.			
Description:	Broken pipe fault/warning shall be triggered if the PI feedback is less than broken pipe level and the drive output frequency is more than broke pipe frequency for delay time.			
P9.6.2^②	Broken pipe level			ID 1854
Minimum value:	0.0 %	Maximum value:	6,000.0 %	Default value: 15.0 %
Description:	Broken pipe level.			
P9.6.3^②	Broken pipe frequency			ID 1856
Minimum value:	1.00 Hz	Maximum value:	MaxFreq Hz	Default value: 25.00 Hz
Description:	Broken pipe frequency.			

Appendix C Parameter Descriptions

Pump parameters (Cont.).

P9.6.4 ^②	<i>Broken pipe delay</i>			ID 1855
Minimum value:	1.0 s	Maximum value:	120.0 s	Default value: 15.0 s
Description:	Broken pipe delay time.			

① Parameter value can only be changed after the drive has stopped.

② Parameter value will be set to be default when changing macros.

Fieldbus (FB) stat.us

P10.1 - FB process data input selection.				
P10.1.1 ^②	<i>FB process data input 1 selection</i>			ID 2533
Minimum value:	0	Maximum value:	12,464	Default value: 0
Description:	<p>With the fieldbus data output selections, parameter/monitor IDs can be assigned to these registers and then read over the desired fieldbus network word for process data. Any drive parameter with an ID can be read over these values.</p> <p>Default values for process data in: Process data IN1 = NULL = ID 0; Process data IN2 = FB PI Set Point1= ID 2542; Process data IN3 = FB PI Feedback1= ID 2550; Process data IN4 = Acceleration time 1= ID 103; Process data IN5 = Deceleration time 1= ID 104; Process data IN6 = Current limit= ID 107; Process data IN7 = NULL= ID 0; or Process data IN8 = NULL= ID 0.</p>			
P10.1.2 ^②	<i>FB process data input 2 selection</i>			ID 2534
Minimum value:	0	Maximum value:	12,464	Default value: 2,542
Description:	<p>With the fieldbus data output selections, parameter/monitor IDs can be assigned to these registers and then read over the desired fieldbus network word for process data. Any drive parameter with an ID can be read over these values.</p> <p>Default values for process data in: Process data IN1 = NULL = ID 0; Process data IN2 = FB PI Set Point1= ID 2542; Process data IN3 = FB PI Feedback1= ID 2550; Process data IN4 = Acceleration time 1= ID 103; Process data IN5 = Deceleration time 1= ID 104; Process data IN6 = Current limit= ID 107; Process data IN7 = NULL= ID 0; or Process data IN8 = NULL= ID 0.</p>			
P10.1.3 ^②	<i>FB process data input 3 selection</i>			ID 2535
Minimum value:	0	Maximum value:	12,464	Default value: 2,550
Description:	<p>With the fieldbus data output selections, parameter/monitor IDs can be assigned to these registers and then read over the desired fieldbus network word for process data. Any drive parameter with an ID can be read over these values.</p> <p>Default values for process data in: Process data IN1 = NULL = ID 0; Process data IN2 = FB PI Set Point1= ID 2542; Process data IN3 = FB PI Feedback1= ID 2550; Process data IN4 = Acceleration time 1= ID 103; Process data IN5 = Deceleration time 1= ID 104; Process data IN6 = Current limit= ID 107; Process data IN7 = NULL= ID 0; or Process data IN8 = NULL= ID 0.</p>			

Appendix C Parameter Descriptions

Fieldbus (FB) status (Cont.).

P10.1.4^②	FB process data input 4 selection			ID 2536
Minimum value:	0	Maximum value:	12,464	Default value: 103
Description:	<p>With the fieldbus data output selections, parameter/monitor IDs can be assigned to these registers and then read over the desired fieldbus network word for process data. Any drive parameter with an ID can be read over these values.</p> <p>Default values for process data in: Process data IN1 = NULL = ID 0; Process data IN2 = FB PI Set Point1= ID 2542; Process data IN3 = FB PI Feedback1= ID 2550; Process data IN4 = Acceleration time 1= ID 103; Process data IN5 = Deceleration time 1= ID 104; Process data IN6 = Current limit= ID 107; Process data IN7 = NULL= ID 0; or Process data IN8 = NULL= ID 0.</p>			
P10.1.5^②	FB process data input 5 selection			ID 2537
Minimum value:	0	Maximum value:	12,464	Default value: 104
Description:	<p>With the fieldbus data output selections, parameter/monitor IDs can be assigned to these registers and then read over the desired fieldbus network word for process data. Any drive parameter with an ID can be read over these values.</p> <p>Default values for process data in: Process data IN1 = NULL = ID 0; Process data IN2 = FB PI Set Point1= ID 2542; Process data IN3 = FB PI Feedback1= ID 2550; Process data IN4 = Acceleration time 1= ID 103; Process data IN5 = Deceleration time 1= ID 104; Process data IN6 = Current limit= ID 107; Process data IN7 = NULL= ID 0; or Process data IN8 = NULL= ID 0.</p>			
P10.1.6^②	FB process data input 6 selection			ID 2538
Minimum value:	0	Maximum value:	12,464	Default value: 107
Description:	<p>With the fieldbus data output selections, parameter/monitor IDs can be assigned to these registers and then read over the desired fieldbus network word for process data. Any drive parameter with an ID can be read over these values.</p> <p>Default values for process data in: Process data IN1 = NULL = ID 0; Process data IN2 = FB PI Set Point1= ID 2542; Process data IN3 = FB PI Feedback1= ID 2550; Process data IN4 = Acceleration time 1= ID 103; Process data IN5 = Deceleration time 1= ID 104; Process data IN6 = Current limit= ID 107; Process data IN7 = NULL= ID 0; or Process data IN8 = NULL= ID 0.</p>			
P10.1.7^②	FB process data input 7 selection			ID 2539
Minimum value:	0	Maximum value:	12,464	Default value: 0
Description:	<p>With the fieldbus data output selections, parameter/monitor IDs can be assigned to these registers and then read over the desired fieldbus network word for process data. Any drive parameter with an ID can be read over these values.</p> <p>Default values for process data in: Process data IN1 = NULL = ID 0; Process data IN2 = FB PI Set Point1= ID 2542; Process data IN3 = FB PI Feedback1= ID 2550; Process data IN4 = Acceleration time 1= ID 103; Process data IN5 = Deceleration time 1= ID 104; Process data IN6 = Current limit= ID 107; Process data IN7 = NULL= ID 0; or Process data IN8 = NULL= ID 0.</p>			

Appendix C Parameter Descriptions

Fieldbus (FB) status (Cont.).

P10.1.8^②	FB process data input 8 selection			ID 2540
Minimum value:	0	Maximum value:	12,464	Default value: 0
Description:	<p>With the fieldbus data output selections, parameter/monitor IDs can be assigned to these registers and then read over the desired fieldbus network word for process data. Any drive parameter with an ID can be read over these values.</p> <p>Default values for process data in: Process data IN1 = NULL = ID 0; Process data IN2 = FB PI Set Point1= ID 2542; Process data IN3 = FB PI Feedback1= ID 2550; Process data IN4 = Acceleration time 1= ID 103; Process data IN5 = Deceleration time 1= ID 104; Process data IN6 = Current limit= ID 107; Process data IN7 = NULL= ID 0; or Process data IN8 = NULL= ID 0.</p>			
P10.2 - FB process data output selection.				
P10.2.1^②	FB process data output 1 selection			ID 1556
Minimum value:	N.A.	Maximum value:	N.A.	Default value: 1
Description:	<p>With the fieldbus data output selections, parameter/monitor IDs can be assigned to these registers and then read over the desired fieldbus network word for process data. Any drive parameter with an ID can be read over these values.</p> <p>Default values for process data out in fieldbus (build table for below values): Process data Out1 = Output frequency = ID 1; Process data Out2 = Motor speed = ID 2; Process data Out3 = Motor current = ID 3; Process data Out4 = Motor torque = ID 4; Process data Out5 = Motor power = ID 5; Process data Out6 = Motor voltage = ID 6; Process data Out7 = DC link voltage = ID 7; or Process data Out8 = Latest fault code = ID 28.</p>			
P10.2.2^②	FB process data output 2 selection			ID 1557
Minimum value:	N.A.	Maximum value:	N.A.	Default value: 2
Description:	<p>With the fieldbus data output selections, parameter/monitor IDs can be assigned to these registers and then read over the desired fieldbus network word for process data. Any drive parameter with an ID can be read over these values.</p> <p>Default values for process data out in fieldbus (build table for below values): Process data Out1 = Output frequency = ID 1; Process data Out2 = Motor speed = ID 2; Process data Out3 = Motor current = ID 3; Process data Out4 = Motor torque = ID 4; Process data Out5 = Motor power = ID 5; Process data Out6 = Motor voltage = ID 6; Process data Out7 = DC link voltage = ID 7; or Process data Out8 = Latest fault code = ID 28.</p>			
P10.2.3^②	FB process data output 3 selection			ID 1558
Minimum value:	N.A.	Maximum value:	N.A.	Default value: 3
Description:	<p>With the fieldbus data output selections, parameter/monitor IDs can be assigned to these registers and then read over the desired fieldbus network word for process data. Any drive parameter with an ID can be read over these values.</p> <p>Default values for process data out in fieldbus (build table for below values): Process data Out1 = Output frequency = ID 1; Process data Out2 = Motor speed = ID 2; Process data Out3 = Motor current = ID 3; Process data Out4 = Motor torque = ID 4; Process data Out5 = Motor power = ID 5; Process data Out6 = Motor voltage = ID 6; Process data Out7 = DC link voltage = ID 7; or Process data Out8 = Latest fault code = ID 28.</p>			

Appendix C Parameter Descriptions

Fieldbus (FB) status (Cont.).

P10.2.4^②	FB process data output 4 selection			ID 1559
Minimum value:	N.A.	Maximum value:	N.A.	Default value: 4
Description:	<p>With the fieldbus data output selections, parameter/monitor IDs can be assigned to these registers and then read over the desired fieldbus network word for process data. Any drive parameter with an ID can be read over these values.</p> <p>Default values for process data out in fieldbus (build table for below values): Process data Out1 = Output frequency = ID 1; Process data Out2 = Motor speed = ID 2; Process data Out3 = Motor current = ID 3; Process data Out4 = Motor torque = ID 4; Process data Out5 = Motor power = ID 5; Process data Out6 = Motor voltage = ID 6; Process data Out7 = DC link voltage = ID 7; or Process data Out8 = Latest fault code = ID 28.</p>			
P10.2.5^②	FB process data output 5 selection			ID 1560
Minimum value:	N.A.	Maximum value:	N.A.	Default value: 5
Description:	<p>With the fieldbus data output selections, parameter/monitor IDs can be assigned to these registers and then read over the desired fieldbus network word for process data. Any drive parameter with an ID can be read over these values.</p> <p>Default values for process data out in fieldbus (build table for below values): Process data Out1 = Output frequency = ID 1; Process data Out2 = Motor speed = ID 2; Process data Out3 = Motor current = ID 3; Process data Out4 = Motor torque = ID 4; Process data Out5 = Motor power = ID 5; Process data Out6 = Motor voltage = ID 6; Process data Out7 = DC link voltage = ID 7; or Process data Out8 = Latest fault code = ID 28.</p>			
P10.2.6^②	FB process data output 6 selection			ID 1561
Minimum value:	N.A.	Maximum value:	N.A.	Default value: 6
Description:	<p>With the fieldbus data output selections, parameter/monitor IDs can be assigned to these registers and then read over the desired fieldbus network word for process data. Any drive parameter with an ID can be read over these values.</p> <p>Default values for process data out in fieldbus (build table for below values): Process data Out1 = Output frequency = ID 1; Process data Out2 = Motor speed = ID 2; Process data Out3 = Motor current = ID 3; Process data Out4 = Motor torque = ID 4; Process data Out5 = Motor power = ID 5; Process data Out6 = Motor voltage = ID 6; Process data Out7 = DC link voltage = ID 7; or Process data Out8 = Latest fault code = ID 28.</p>			
P10.2.7^②	FB process data output 7 selection			ID 1562
Minimum value:	N.A.	Maximum value:	N.A.	Default value: 7
Description:	<p>With the fieldbus data output selections, parameter/monitor IDs can be assigned to these registers and then read over the desired fieldbus network word for process data. Any drive parameter with an ID can be read over these values.</p> <p>Default values for process data out in fieldbus (build table for below values): Process data Out1 = Output frequency = ID 1; Process data Out2 = Motor speed = ID 2; Process data Out3 = Motor current = ID 3; Process data Out4 = Motor torque = ID 4; Process data Out5 = Motor power = ID 5; Process data Out6 = Motor voltage = ID 6; Process data Out7 = DC link voltage = ID 7; or Process data Out8 = Latest fault code = ID 28.</p>			

Appendix C Parameter Descriptions

Fieldbus (FB) status (Cont.).

P10.2.8^②	FB process data output 8 selection			ID 1563
Minimum value:	N.A.	Maximum value:	N.A.	Default value: 28
Description:	<p>With the fieldbus data output selections, parameter/monitor IDs can be assigned to these registers and then read over the desired fieldbus network word for process data. Any drive parameter with an ID can be read over these values.</p> <p>Default values for process data out in fieldbus (build table for below values): Process data Out1 = Output frequency = ID 1; Process data Out2 = Motor speed = ID 2; Process data Out3 = Motor current = ID 3; Process data Out4 = Motor torque = ID 4; Process data Out5 = Motor power = ID 5; Process data Out6 = Motor voltage = ID 6; Process data Out7 = DC link voltage = ID 7; or Process data Out8 = Latest fault code = ID 28.</p>			
P10.3 - Standard status word.				
P10.3.1^②	Standard status word Bit0 function select			ID 2415
Minimum value:	N.A.	Maximum value:	N.A.	Default value: 1
Options:	<p>0 = Not used; 1 = Ready; 2 = Run; 3 = Fault; 4 = Fault invert; 5 = Warning; 6 = Reversed; 7 = At speed; 8 = Zero frequency; 9 = Frequency limit supervision; 10 = Pl supervision; 11 = Torque limit supervision; 12 = Reference limit supervision; 13 = Power limit supervision; 14 = Temperature limit supervision; 15 = Analog input supervision; 16 = Motor current supervision; 17 = Over heat fault; 18 = Overcurrent regular; 19 = Overvoltage regular; 20 = Undervoltage regular; 21 = 4 mA reference fault/warning; 22 = External fault/warning; 23 = Motor thermal protection; 24 = STO fault output; 25 = Control from I/O; 26 = Remote control; 27 = Un-requested rotation direction; 28 = Fire mode; 29 = Damper control; 30 = Valve control; 31 = Jog speed select; 32 = Fieldbus digital input 1; 33 = Fieldbus digital input 2; 34 = DC charge switch close; 35 = Preheat active; 36 = Cold weather active; 37 = Pl Sleep 38 = 2nd stage ramp frequency active; 39 = Prime pump active; 40 = Master drive state; 41 = Slave drive state; or 43 = Single drive control.</p>			
Description:	<p>This parameter allows for setting one of the RO functions to a status word that then can be read over the communication standard status word. This also can be viewed in the keypad monitor value M5.3.</p>			

Appendix C Parameter Descriptions

Fieldbus (FB) status (Cont.).

P10.3.2 ^②	Standard status word Bit 1 function select			ID 2416
Minimum value:	N.A.	Maximum value:	N.A.	Default value: 2
Options:	0 = Not used; 1 = Ready; 2 = Run; 3 = Fault; 4 = Fault invert; 5 = Warning; 6 = Reversed; 7 = At speed; 8 = Zero frequency; 9 = Frequency limit supervision; 10 = PI supervision; 11 = Torque limit supervision; 12 = Reference limit supervision; 13 = Power limit supervision; 14 = Temperature limit supervision; 15 = Analog input supervision; 16 = Motor current supervision; 17 = Over heat fault; 18 = Overcurrent regular; 19 = Overvoltage regular; 20 = Undervoltage regular; 21 = 4 mA reference fault/warning; 22 = External fault/warning; 23 = Motor thermal protection; 24 = STO fault output; 25 = Control from I/O; 26 = Remote control; 27 = Un-requested rotation direction; 28 = Fire mode; 29 = Damper control; 30 = Valve control; 31 = Jog speed select; 32 = Fieldbus digital input 1; 33 = Fieldbus digital input 2; 34 = DC charge switch close; 35 = Preheat active; 36 = Cold weather active; 37 = PI Sleep 38 = 2nd stage ramp frequency active; 39 = Prime pump active; 40 = Master drive state; 41 = Slave drive state; or 43 = Single drive control.			
Description:	This parameter allows for setting one of the RO functions to a status word that then can be read over the communication standard status word. This also can be viewed in the keypad monitor value M5.3.			

Appendix C Parameter Descriptions

Fieldbus (FB) status (Cont.).

P10.3.3 ^②	Standard status word Bit 2 function select			ID 2417
Minimum value:	N.A.	Maximum value:	N.A.	Default value: 3
Options:	0 = Not used; 1 = Ready; 2 = Run; 3 = Fault; 4 = Fault invert; 5 = Warning; 6 = Reversed; 7 = At speed; 8 = Zero frequency; 9 = Frequency limit supervision; 10 = PI supervision; 11 = Torque limit supervision; 12 = Reference limit supervision; 13 = Power limit supervision; 14 = Temperature limit supervision; 15 = Analog input supervision; 16 = Motor current supervision; 17 = Over heat fault; 18 = Overcurrent regular; 19 = Overvoltage regular; 20 = Undervoltage regular; 21 = 4 mA reference fault/warning; 22 = External fault/warning; 23 = Motor thermal protection; 24 = STO fault output; 25 = Control from I/O; 26 = Remote control; 27 = Un-requested rotation direction; 28 = Fire mode; 29 = Damper control; 30 = Valve control; 31 = Jog speed select; 32 = Fieldbus digital input 1; 33 = Fieldbus digital input 2; 34 = DC charge switch close; 35 = Preheat active; 36 = Cold weather active; 37 = PI Sleep 38 = 2nd stage ramp frequency active; 39 = Prime pump active; 40 = Master drive state; 41 = Slave drive state; or 43 = Single drive control.			
Description:	This parameter allows for setting one of the RO functions to a status word that then can be read over the communication standard status word. This also can be viewed in the keypad monitor value M5.3.			

Appendix C Parameter Descriptions

Fieldbus (FB) status (Cont.).

P10.3.4 ^②	Standard status word Bit 3 function select			ID 2418
Minimum value:	N.A.	Maximum value:	N.A.	Default value: 4
Options:	0 = Not used; 1 = Ready; 2 = Run; 3 = Fault; 4 = Fault invert; 5 = Warning; 6 = Reversed; 7 = At speed; 8 = Zero frequency; 9 = Frequency limit supervision; 10 = PI supervision; 11 = Torque limit supervision; 12 = Reference limit supervision; 13 = Power limit supervision; 14 = Temperature limit supervision; 15 = Analog input supervision; 16 = Motor current supervision; 17 = Over heat fault; 18 = Overcurrent regular; 19 = Overvoltage regular; 20 = Undervoltage regular; 21 = 4 mA reference fault/warning; 22 = External fault/warning; 23 = Motor thermal protection; 24 = STO fault output; 25 = Control from I/O; 26 = Remote control; 27 = Un-requested rotation direction; 28 = Fire mode; 29 = Damper control; 30 = Valve control; 31 = Jog speed select; 32 = Fieldbus digital input 1; 33 = Fieldbus digital input 2; 34 = DC charge switch close; 35 = Preheat active; 36 = Cold weather active; 37 = PI Sleep 38 = 2nd stage ramp frequency active; 39 = Prime pump active; 40 = Master drive state; 41 = Slave drive state; or 43 = Single drive control.			
Description:	This parameter allows for setting one of the RO functions to a status word that then can be read over the communication standard status word. This also can be viewed in the keypad monitor value M5.3.			

Appendix C Parameter Descriptions

Fieldbus (FB) status (Cont.).

P10.3.5 ^②	Standard status word Bit 4 function select			ID 2419
Minimum value:	N.A.	Maximum value:	N.A.	Default value: 5
Options:	0 = Not used; 1 = Ready; 2 = Run; 3 = Fault; 4 = Fault invert; 5 = Warning; 6 = Reversed; 7 = At speed; 8 = Zero frequency; 9 = Frequency limit supervision; 10 = PI supervision; 11 = Torque limit supervision; 12 = Reference limit supervision; 13 = Power limit supervision; 14 = Temperature limit supervision; 15 = Analog input supervision; 16 = Motor current supervision; 17 = Over heat fault; 18 = Overcurrent regular; 19 = Overvoltage regular; 20 = Undervoltage regular; 21 = 4 mA reference fault/warning; 22 = External fault/warning; 23 = Motor thermal protection; 24 = STO fault output; 25 = Control from I/O; 26 = Remote control; 27 = Un-requested rotation direction; 28 = Fire mode; 29 = Damper control; 30 = Valve control; 31 = Jog speed select; 32 = Fieldbus digital input 1; 33 = Fieldbus digital input 2; 34 = DC charge switch close; 35 = Preheat active; 36 = Cold weather active; 37 = PI Sleep 38 = 2nd stage ramp frequency active; 39 = Prime pump active; 40 = Master drive state; 41 = Slave drive state; or 43 = Single drive control.			
Description:	This parameter allows for setting one of the RO functions to a status word that then can be read over the communication standard status word. This also can be viewed in the keypad monitor value M5.3.			

Appendix C Parameter Descriptions

Fieldbus (FB) status (Cont.).

P10.3.6 ^②	Standard status word Bit 5 function select			ID 2420
Minimum value:	N.A.	Maximum value:	N.A.	Default value: 6
Options:	0 = Not used; 1 = Ready; 2 = Run; 3 = Fault; 4 = Fault invert; 5 = Warning; 6 = Reversed; 7 = At speed; 8 = Zero frequency; 9 = Frequency limit supervision; 10 = PI supervision; 11 = Torque limit supervision; 12 = Reference limit supervision; 13 = Power limit supervision; 14 = Temperature limit supervision; 15 = Analog input supervision; 16 = Motor current supervision; 17 = Over heat fault; 18 = Overcurrent regular; 19 = Overvoltage regular; 20 = Undervoltage regular; 21 = 4 mA reference fault/warning; 22 = External fault/warning; 23 = Motor thermal protection; 24 = STO fault output; 25 = Control from I/O; 26 = Remote control; 27 = Un-requested rotation direction; 28 = Fire mode; 29 = Damper control; 30 = Valve control; 31 = Jog speed select; 32 = Fieldbus digital input 1; 33 = Fieldbus digital input 2; 34 = DC charge switch close; 35 = Preheat active; 36 = Cold weather active; 37 = PI Sleep 38 = 2nd stage ramp frequency active; 39 = Prime pump active; 40 = Master drive state; 41 = Slave drive state; or 43 = Single drive control.			
Description:	This parameter allows for setting one of the RO functions to a status word that then can be read over the communication standard status word. This also can be viewed in the keypad monitor value M5.3.			

Appendix C Parameter Descriptions

Fieldbus (FB) status (Cont.).

P10.3.7 ^②	Standard status word Bit 6 function select			ID 2421	
Minimum value:	N.A.	Maximum value:	N.A.	Default value:	7
Options:	0 = Not used; 1 = Ready; 2 = Run; 3 = Fault; 4 = Fault invert; 5 = Warning; 6 = Reversed; 7 = At speed; 8 = Zero frequency; 9 = Frequency limit supervision; 10 = PI supervision; 11 = Torque limit supervision; 12 = Reference limit supervision; 13 = Power limit supervision; 14 = Temperature limit supervision; 15 = Analog input supervision; 16 = Motor current supervision; 17 = Over heat fault; 18 = Overcurrent regular; 19 = Overvoltage regular; 20 = Undervoltage regular; 21 = 4 mA reference fault/warning; 22 = External fault/warning; 23 = Motor thermal protection; 24 = STO fault output; 25 = Control from I/O; 26 = Remote control; 27 = Un-requested rotation direction; 28 = Fire mode; 29 = Damper control; 30 = Valve control; 31 = Jog speed select; 32 = Fieldbus digital input 1; 33 = Fieldbus digital input 2; 34 = DC charge switch close; 35 = Preheat active; 36 = Cold weather active; 37 = PI Sleep 38 = 2nd stage ramp frequency active; 39 = Prime pump active; 40 = Master drive state; 41 = Slave drive state; or 43 = Single drive control.				
Description:	This parameter allows for setting one of the RO functions to a status word that then can be read over the communication standard status word. This also can be viewed in the keypad monitor value M5.3.				

Appendix C Parameter Descriptions

Fieldbus (FB) status (Cont.).

P10.3.8 ^②	<i>Standard status word Bit 7 function select</i>				ID 2422
Minimum value:	N.A.	Maximum value:	N.A.	Default value:	8
Options:	0 = Not used; 1 = Ready; 2 = Run; 3 = Fault; 4 = Fault invert; 5 = Warning; 6 = Reversed; 7 = At speed; 8 = Zero frequency; 9 = Frequency limit supervision; 10 = PI supervision; 11 = Torque limit supervision; 12 = Reference limit supervision; 13 = Power limit supervision; 14 = Temperature limit supervision; 15 = Analog input supervision; 16 = Motor current supervision; 17 = Over heat fault; 18 = Overcurrent regular; 19 = Overvoltage regular; 20 = Undervoltage regular; 21 = 4 mA reference fault/warning; 22 = External fault/warning; 23 = Motor thermal protection; 24 = STO fault output; 25 = Control from I/O; 26 = Remote control; 27 = Un-requested rotation direction; 28 = Fire mode; 29 = Damper control; 30 = Valve control; 31 = Jog speed select; 32 = Fieldbus digital input 1; 33 = Fieldbus digital input 2; 34 = DC charge switch close; 35 = Preheat active; 36 = Cold weather active; 37 = PI Sleep 38 = 2nd stage ramp frequency active; 39 = Prime pump active; 40 = Master drive state; 41 = Slave drive state; or 43 = Single drive control.				
Description:	This parameter allows for setting one of the RO functions to a status word that then can be read over the communication standard status word. This also can be viewed in the keypad monitor value M5.3.				

^① Parameter value can only be changed after the drive has stopped.

^② Parameter value will be set to be default when changing macros.

Serial communication

P11.1 - Basic settings.					
P11.1.1 ^①	<i>Serial communication</i>				ID 586
Minimum value:	N.A.	Maximum value:	N.A.	Default value:	0
Options:	0 = Modbus RTU; 1 = BACnet MSTP (*EVM PRO); or 2 = SWD (*EVM PRO).				
Description:	This parameter defines the communication protocol for RS-485.				
P11.2 - Modbus RTU.					
P11.2.1 ^①	<i>Slave address</i>				ID 587
Minimum value:	1	Maximum value:	247	Default value:	1
Description:	This parameter defines the slave address for RS-485 communication.				

Appendix C Parameter Descriptions

Serial communication (Cont.).

P11.2.2^①	Baud rate			ID 584
Minimum value:	N.A.	Maximum value:	N.A.	Default value: 1
Options:	0 = 9,600; 1 = 19,200; 2 = 38,400; 3 = 57,600; or 4 = 115,200			
Description:	This parameter defines communication speed for RS-485 communication.			
P11.2.3^①	Parity type			ID 585
Minimum value:	N.A.	Maximum value:	N.A.	Default value: 2
Options:	0 = None; 1 = Odd; or 2 = Even.			
Description:	This parameter defines parity type for RS-485 communication.			
P11.2.4	Modbus RTU protocol status			ID 588
Minimum value:	N.A.	Maximum value:	N.A.	Default value: N.A.
Options:	0 = Initial; 1 = Stopped; 2 = Operational; or 3 = Faulted.			
Description:	This parameter shows the protocol status for RS-485 communication.			
P11.2.5	Communication timeout modbus RTU			ID 593
Minimum value:	0 ms	Maximum value:	60,000 ms	Default value: 10,000 ms
Description:	Selects the time to wait before a communication fault occurs over modbus RTU if a message is not received.			
P11.2.6	Modbus RTU fault response			ID 2516
Minimum value:	N.A.	Maximum value:	N.A.	Default value: 0
Options:	0 - Only in fieldbus control mode. When fieldbus is the control place and fieldbus fault is active, the drive will fault on loss of communications; if not in fieldbus control, place will not fault. 1 - In all control modes. No matter the control place setting, if communication is lost, fieldbus fault response will occur.			
Description:	Defines the fieldbus fault condition for modbus RTU communication.			
P11.3 - BACnet MSTP.				
P11.3.1^①	MSTP baud rate			ID 594
Minimum value:	N.A.	Maximum value:	N.A.	Default value: 2
Options:	0 = 9,600; 1 = 19,200; 2 = 38,400; 3 = 76,800; or 4 = 115,200.			
Description:	This parameter defines the communication speed for RS-485 communication.			
P11.3.2^①	MSTP device address			ID 595
Minimum value:	0	Maximum value:	127	Default value: 1
Description:	Defines the device address of the drive on the BACnet MSTP network.			
P11.3.3^①	MSTP instance number			ID 596
Minimum value:	0	Maximum value:	4,194,302	Default value: 0
Description:	Defines the instance number of the drive on the BACnet MSTP network.			
P11.3.4	MSTP communication timeout			ID 598
Minimum value:	0 ms	Maximum value:	60,000 ms	Default value: 10,000 ms
Description:	Selects the time to wait before a communication fault occurs over BACnet MSTP if a message is not received.			

Appendix C Parameter Descriptions

Serial communication (Cont.).

P11.3.5	MSTP protocol status			ID 599
Minimum value:	N.A.	Maximum value:	N.A.	Default value: N.A.
Options:	0 = Stopped; 1 = Operational; or 2 = Faulted.			
Description:	This parameter shows the protocol status for BACnet MSTP communication.			
P11.3.6	MSTP fault code			ID 600
Minimum value:	N.A.	Maximum value:	N.A.	Default value: N.A.
Options:	0 = None; 1 = Sole master; 2 = Duplicate MAC ID; or 3 = Baud rate fault.			
Description:	This parameter shows the protocol status for BACnet MSTP communication.			
P11.3.7	MSTP fault response			ID 2526
Minimum value:	N.A.	Maximum value:	N.A.	Default value: 0
Options:	0 = Only in fieldbus control mode - when fieldbus is the control place and fieldbus fault is active, the drive will fault on loss of communications. If not in fieldbus control, place will not fault. 1 = In all control modes - no matter the control place setting. If communication is lost, fieldbus fault response will occur.			
Description:	Defines the fieldbus fault condition for BACnet MSTP communication.			
P11.3.8	MSTP maximum master			ID 1537
Minimum value:	1	Maximum value:	127	Default value: 127
Description:	Defines the maximum number of masters that can establish connections with the drive.			
P11.5 - SWD.				
P11.5.1	Parameter access			ID 2630
Minimum value:	N.A.	Maximum value:	N.A.	Default value: 1
Options:	0 = No permission to read/write on acyclic channel; or 1 = Acyclic read/write are allowed on Profibus.			
Description:	PNU927 which specifies the operation priority of parameters for acyclic communication.			
P11.5.2^①	Parameter data access			ID 2631
Minimum value:	N.A.	Maximum value:	N.A.	Default value: 4
Options:	0 = Local control; 1 = Fieldbus; 2 = Mixed interface; 4 = NET, local on fault; or 5 = Dual mode.			
Description:	PNU928 which specifies the control priority of the device for cyclic communication.			
P11.5.3	Fault situation counter			ID 2632
Minimum value:	N.A.	Maximum value:	N.A.	Default value: N.A.
Description:	PNU952 which specifies the fault situation counter. Only write of 0 is allowed, then the whole fault buffer (actual fault situation and all other fault situations) and the fault message counter (parameter 944) are erased.			
P11.5.4	Board status			ID 2609
Minimum value:	N.A.	Maximum value:	N.A.	Default value: 0
Description:	Status of the board: B0-DCOM communication fault; B1-Board HW fault; B2-IO1 24 volt overload fault; B3-Profibus communication fault; or B4-fieldbus fault.			

Appendix C Parameter Descriptions

Serial communication (Cont.).

P11.5.5	Firmware version				ID 2610
Minimum value:	N.A.	Maximum value:	N.A.	Default value:	N.A.
Description:	This parameter provides the firmware version of the SWD.				
P11.5.6	Protocol status				ID 2612
Minimum value:	N.A.	Maximum value:	N.A.	Default value:	0
Options:	0 = Not configured; 1 = Operational; or 2 = Diagnostics.				
Description:	This parameter specifies the protocol status for SWD card.				
P11.6 - Bluetooth.					
P11.6.1	Bluetooth enabled				ID 1895
Minimum value:	N.A.	Maximum value:	N.A.	Default value:	0
Options:	0 = Disabled; or 1 = Enabled.				
Description:	Bluetooth enabled.				
P11.6.2^②	Bluetooth broadcast mode				ID 2920
Minimum value:	N.A.	Maximum value:	N.A.	Default value:	0
Options:	0 = Off; or 1 = On.				
Description:	Bluetooth broadcast mode.				
P11.6.3	Bluetooth pairing reset				ID 2935
Minimum value:	N.A.	Maximum value:	N.A.	Default value:	N.A.
Options:	0 = Not reset; or 1 = Reset.				
Description:	Bluetooth pairing reset.				

^① Parameter value can only be changed after the drive has stopped.

^② Parameter value will be set to be default when changing macros.

Ethernet communication

P12.1 - Basic settings.					
P12.1.1^①	IP address mode				ID 1500
Minimum value:	N.A.	Maximum value:	N.A.	Default value:	0
Options:	0 = Static IP; or 1 = DHCP with AutoIP.				
Description:	This parameter defined the IP address configuration mode for EIP/modbus TCP.				
P12.1.2	Active IP address				ID 1507
Minimum value:	N.A.	Maximum value:	N.A.	Default value:	N.A.
Description:	Reads the current active IP address.				
P12.1.3	Active subnet mask				ID 1509
Minimum value:	N.A.	Maximum value:	N.A.	Default value:	N.A.
Description:	Reads the current active subnet mask.				
P12.1.4	Active default gateway				ID 1511
Minimum value:	N.A.	Maximum value:	N.A.	Default value:	N.A.
Description:	Reads the current active default gateway.				

Appendix C Parameter Descriptions

Ethernet communication (Cont.).

P12.1.5	MAC address			ID 1513	
Minimum value:	N.A.	Maximum value:	N.A.	Default value:	N.A.
Description:	Reads the current MAC address.				
P12.1.6^①	Static IP address			ID 1501	
Minimum value:	N.A.	Maximum value:	N.A.	Default value:	192.168.1.254
Description:	Defines the static IP address.				
P12.1.7^①	Static subnet mask			ID 1503	
Minimum value:	N.A.	Maximum value:	N.A.	Default value:	255.255.255.0
Description:	Defines the static subnet mask.				
P12.1.8^①	Static default gateway			ID 1505	
Minimum value:	N.A.	Maximum value:	N.A.	Default value:	192.168.1.1
Description:	Defines the static default gateway.				
P12.1.9	Ethernet communication timeout			ID 611	
Minimum value:	0 ms	Maximum value:	60,000 ms	Default value:	10,000 ms
Description:	Selects the time it waits before a communication fault occurs over ethernet.				
P12.2 - Trusted IP filter (EVM PRO only).					
P12.2.1	Trusted IP white list			ID 68	
Minimum value:	N.A.	Maximum value:	N.A.	Default value:	0.0.0.0 0.0.0.0 192.168.1.255
Description:	Defines the IP addresses in the white list. A setting of 192.168.1.255 enables all connections on the local subnet.				
P12.2.2	Trusted IP filter enable			ID 76	
Minimum value:	N.A.	Maximum value:	N.A.	Default value:	1
Options:	0 = Disabled; or 1 = Enabled.				
Description:	Enables IP white listing. Devices not in the white list will not be able to establish communications with the drive.				
P12.3 - Modbus TCP (EVM PRO only).					
P12.3.1^①	Modbus TCP enable			ID 1942	
Minimum value:	N.A.	Maximum value:	N.A.	Default value:	0
Options:	0 = Disable; or 1 = Enable.				
Description:	Enables modbus TCP communications				
P12.3.2	Modbus TCP connection limit			ID 609	
Minimum value:	N.A.	Maximum value:	N.A.	Default value:	5
Description:	Maximum number of connections allowed to the drive.				
P12.3.3	Modbus TCP unit identifier number			ID 610	
Minimum value:	N.A.	Maximum value:	N.A.	Default value:	1
Description:	Unit identifier unit value for modbus TCP.				
P12.3.4	Modbus TCP protocol status			ID 612	
Minimum value:	N.A.	Maximum value:	N.A.	Default value:	N.A.
Options:	0 = Stopped; 1 = Operational; or 2 = Faulted.				
Description:	This parameter shows the protocol status for modbus TCP communication.				

Appendix C Parameter Descriptions

Ethernet communication (Cont.).

P12.3.5	Modbus TCP fault response			ID 2517
Minimum value:	N.A.	Maximum value:	N.A.	Default value: 0
Options:	0 = Only in fieldbus control mode - when fieldbus is the control place and fieldbus fault is active, the drive will fault on loss of communications. If not in fieldbus control, place will not fault. 1 = In all control modes - no matter the control place setting, if communication is lost, fieldbus fault response will occur.			
Description:	Defines the fieldbus fault condition for modbus TCP communication.			
P12.4 - Ethernet IP (EVM PRO only).				
P12.4.1^①	Ethernet based protocol select			ID 1997
Minimum value:	N.A.	Maximum value:	N.A.	Default value: 0
Options:	0 = Disabled; or 2 = BACnet IP.			
Description:	Selects the active communication protocol on the ethernet I/P port.			
P12.4.2	Ethernet IP protocol status			ID 608
Minimum value:	N.A.	Maximum value:	N.A.	Default value: N.A.
Options:	0 = Off; 1 = Operational; or 2 = Faulted.			
Description:	Indicates if ethernet protocol is active or not.			
P12.4.3	Ethernet IP fault response			ID 2518
Minimum value:	N.A.	Maximum value:	N.A.	Default value: 0
Options:	0 = Only in fieldbus control mode - when fieldbus is the control place and Fieldbus fault is active, the drive will fault on loss of communications. If not in fieldbus control, place will not fault. 1 = In all control modes - no matter the control place setting. If communication is lost, fieldbus fault response will occur.			
Description:	Defines the fieldbus fault condition for ethernet IP communication.			
P12.5 - BACnet IP (EVM PRO only).				
P12.5.1^①	BACnet IP UDP port number			ID 1733
Minimum value:	N.A.	Maximum value:	N.A.	Default value: 47,808
Options:	47808 = BAC0; 47809 = BAC1; 47810 = BAC2; 47811 = BAC3; 47812 = BAC4; 47813 = BAC5; 47814 = BAC6; 47815 = BAC7; 47816 = BAC8; 47817 = BAC9; 47818 = BACA; 47819 = BACB; 47820 = BACC; 47821 = BACD; 47822 = BACE; or 47823 = BACF.			
Description:	Defines the BACnet UDP port number.			
P12.5.2^①	BACnet IP foreign device			ID 1734
Minimum value:	N.A.	Maximum value:	N.A.	Default value: 0
Options:	0 = Disabled; or 1 = Enabled.			
Description:	Enables BACNET IP foreign device configuration.			

Appendix C Parameter Descriptions

Ethernet communication (Cont.).

P12.5.3^①	BACnet IP BBMD IP			ID 1735
Minimum value:	N.A.	Maximum value:	N.A.	Default value: 0.0.0.0
Description:	Displays the BACnet BBMD IP address.			
P12.5.4^①	BACnet IP UDP port			ID 1737
Minimum value:	N.A.	Maximum value:	N.A.	Default value: 47,808
Options:	47808 = BAC0; 47809 = BAC1; 47810 = BAC2; 47811 = BAC3; 47812 = BAC4; 47813 = BAC5; 47814 = BAC6; 47815 = BAC7; 47816 = BAC8; 47817 = BAC9; 47818 = BACA; 47819 = BACB; 47820 = BACC; 47821 = BACD; 47822 = BACE; or 47823 = BACF.			
Description:	Displays the BACnet BBMD UDP port number.			
P12.5.5^①	BACnet IP registration interval			ID 1738
Minimum value:	0	Maximum value:	65,535	Default value: 10
Description:	Defines the registration interval.			
P12.5.6	BACnet IP communication timeout			ID 1739
Minimum value:	0 ms	Maximum value:	60,000 ms	Default value: 0 ms
Description:	Selects the time it waits before a communication fault occurs over BACnet IP.			
P12.5.7	BACnet IP protocol status			ID 1740
Minimum value:	N.A.	Maximum value:	N.A.	Default value: 0
Options:	0 = Stopped; 1 = Operational; or 2 = Faulted.			
Description:	This parameter shows the protocol status for BACnet IP communication.			
P12.5.8	BACnet IP fault behavior			ID 1741
Minimum value:	N.A.	Maximum value:	N.A.	Default value: 0
Options:	0 = Only in fieldbus control mode - when fieldbus is the control place and Fieldbus fault is active, the drive will fault on loss of communications. If not in fieldbus control, place will not fault. 1 = In all control modes - no matter the control place setting. If communication is lost, fieldbus fault response will occur.			
Description:	Defines the fieldbus fault condition for BACnet IP communication.			
P12.5.9^①	BACnet IP instance number			ID 1742
Minimum value:	0	Maximum value:	4,194,302	Default value: 0
Description:	Displays the BACnet instance number.			
P12.6 - Web UI (EVM PRO only).				
P12.6.1	Web UI protocol status			ID 2915
Minimum value:	N.A.	Maximum value:	N.A.	Default value: N.A.
Options:	0 = Off; 1 = Operational; or 2 = Faulted.			
Description:	This parameter shows the protocol status for web server communication.			

Appendix C Parameter Descriptions

Ethernet communication (Cont.).

P12.6.2	Web UI fault response			ID 2916
Minimum value:	N.A.	Maximum value:	N.A.	Default value: 0
Options:	0 = Only in fieldbus control mode - when fieldbus is the control place and fieldbus fault is active, the drive will fault on loss of communications. If not in fieldbus control, place will not fault. 1 = In all control modes - no matter the control place setting. If communication is lost, fieldbus fault response will occur.			
Description:	Defines the fieldbus fault condition for web server communication.			
P12.6.3	Web UI communication timeout			ID 2919
Minimum value:	30,000 ms	Maximum value:	60,000 ms	Default value: 60,000 ms
Description:	Selects the time it waits before a communication fault occurs over the web server.			
P12.6.4^①	Web UI enable			ID 2921
Minimum value:	N.A.	Maximum value:	N.A.	Default value: 0
Options:	0 = Disabled; or 1 = Enabled.			
Description:	Enables web server configuration and monitoring page.			

^① Parameter value can only be changed after the drive has stopped.

^② Parameter value will be set to be default when changing macros.

System

P13.1 - Basic settings.				
P13.1.1	Language			ID 340
Minimum value:	N.A.	Maximum value:	N.A.	Default value: 0
Options:	0 = English; 1 = English; or 2 = English.			
Description:	This parameter offers the ability to control the frequency converter through the keypad in the language of your choice. Currently available language is English only.			
P13.1.2^①	Application			ID 142
Minimum value:	N.A.	Maximum value:	N.A.	Default value: N.A.
Options:	0 = Standard;; 1 = Pump; 2 = Fan; or 3 = Multi-purpose.			
Description:	This parameter sets the active application if multiple applications have been loaded.			
P13.1.3^①	Parameter sets			ID 619
Minimum value:	N.A.	Maximum value:	N.A.	Default value: N.A.
Options:	0 = No; 1 = Load factory default parameters; 2 = Reload set 1; 3 = Reload set 2; 4 = Store parameter set 1; 5 = Store parameter set 2; 6 = Reset; or 7 = Reload defaults VM.			
Description:	This parameter allows you to reload the factory default parameter values, and to store and load two customized parameter sets.			
P13.1.4	Up to keypad			ID 620
Minimum value:	N.A.	Maximum value:	N.A.	Default value: N.A.
Options:	0 = No; or 1 = Yes (all parameters).			
Description:	This function uploads all existing parameter groups to the keypad.			

Appendix C Parameter Descriptions

P13.1.5^①	<i>Down from keypad</i>				ID 621
Minimum value:	N.A.	Maximum value:	N.A.	Default value:	N.A.
Options:	0 = No; 1 = All parameters; 2 = All, no motor; or 3 = Application parameters.				
Description:	This function downloads one or all parameter groups from the keypad to the drive.				
P13.1.6	<i>Parameter comparison</i>				ID 623
Minimum value:	N.A.	Maximum value:	N.A.	Default value:	N.A.
Options:	0 = No; 1 = Compare with keypad; 2 = Compare with default; 3 = Compare with Set 1; or 4 = Compare with Set 2.				
Description:	<p>With the parameter comparison function, you can compare the actual parameter values to the values of your customized parameter sets and those loaded to the control keypad.</p> <p>The actual parameter values are first compared to those of the customized parameter Set 1. If no differences are detected, a “0” is displayed on the lowermost line of the keypad.</p> <p>If any of the parameter values differ from those of the Set 1 parameters, the number of the deviations is displayed together.</p> <p>By pressing the right arrow button, once again you will see both the actual value and the value it was compared to. In this display, the value on the description line (in the middle) is the default value, and the one on the value line (lowermost line) is the edited value. You can also edit the actual value by pushing the right arrow button.</p> <p>Actual values can also be compared to Set 2, factory settings, and keypad set values.</p>				
P13.1.7	<i>Parameter lock PIN</i>				ID 624
Minimum value:	0	Maximum value:	9,999	Default value:	0
Description:	<p>The application selection can be protected against unauthorized changes with the password function. When the password function is enabled, the user will be prompted to enter a password before application changes, parameter value changes, or password changes.</p> <p>By default, the password function is not in use. If you want to activate the password, change the value of this parameter to any number between 1 and 9,999.</p> <p>To deactivate the password, reset the parameter value to 0.</p>				
P13.1.8	<i>Keypad parameter lock</i>				ID 625
Minimum value:	N.A.	Maximum value:	N.A.	Default value:	0
Options:	0 = Change enable; or 1 = Change disable.				
Description:	<p>This function allows the user to prohibit changes to the parameters. If the parameter lock is activated, the text “locked” will appear on the display if you try to edit a parameter value.</p> <p>Note: This function does not prevent unauthorized editing of parameter values.</p>				
P13.1.9	<i>Start-up Wizard</i>				ID 626
Minimum value:	N.A.	Maximum value:	N.A.	Default value:	0
Options:	0 = Enabled. 1 = Disabled.				
Description:	<p>The Start-up Wizard facilitates commissioning the EVM PRO. If selected “Enable”, the Start-up Wizard prompts the operator for the application desired and then advances parameters through the start-up parameter list/Application Mini wizard in keypad. After completion, it allows the user to go to the main menu or default page and this parameter is set to “Disabled”. The Start-up Wizard is always enabled for the initial power up of the EVM PRO. By setting this parameter to “Disable” without going through the Start-up Wizard, it will not cause it to be active on start-up. If user goes into Start-up Wizard after completion, or defaults drive, the Start-up Wizard will be “Enabled”.</p>				

Appendix C Parameter Descriptions

P13.2 - Keypad.					
P13.2.1	Local default page				ID 1875
Minimum value:	N.A.	Maximum value:	N.A.	Default value:	0
Options:	0 = None; or 1 = Monitor.				
Description:	Local default page selection.				
P13.2.2	Local monitor parameter set				ID 1876
Minimum value:	N.A.	Maximum value:	N.A.	Default value:	1,1,0
Description:	Local monitor parameter path. Default path is M1.1.				
P13.2.3	Default page				ID 628
Minimum value:	N.A.	Maximum value:	N.A.	Default value:	0
Options:	0 = None; 1 = Main menu; 2 = Multi-monitor; 3 = Favorite menu; or 4 = Keypad reference.				
Description:	This parameter sets the view to which the display automatically moves as the timeout time expires or when the keypad power is switched on. If the default page value is 0, the function is not activated: i.e., the last displayed page remains on the keypad display.				
P13.2.4	Timeout time				ID 629
Minimum value:	1 s	Maximum value:	65,535 s.	Default value:	30 s
Description:	The timeout time setting defines the time after which the keypad display returns to the Default Page. Note: If the default page value is 0, the timeout time setting has no effect.				
P13.2.5	Contrast adjust				ID 630
Minimum value:	5	Maximum value:	18	Default value:	12
Description:	If the remote keypad display is not clear, you can adjust the keypad contrast with this parameter.				
P13.2.6	Backlight time				ID 631
Minimum value:	1 min.	Maximum value:	65,535 min.	Default value:	10 min.
Description:	This parameter determines how long the backlight stays on before going out.				
P13.2.7	Fan control				ID 632
Minimum value:	N.A.	Maximum value:	N.A.	Default value:	1
Options:	0 = Continuous - fan runs continuously. 1 = Temperature - based on the temperature of the unit. The fan is switched on automatically when the heat sink temperature reaches 60°C (140°F). The fan receives a stop command when the heat sink temperature falls to 55°C (131°F). The fan runs for about a minute after receiving the stop command or switching on the power, as well as after changing the value from "Continuous" to "Temperature". 2 = Run follow - after power up, the fan is stopped until the run command is given and then fan runs continuously. This is mainly made for common DC-bus systems to prevent cooling fans to load charging resistors on power up moment.				
Description:	This function allows you to control the EVM PRO's cooling fan. You can set the fan to run as stated in the options.				
P13.2.8	Keypad ACK timeout				ID 633
Minimum value:	200 ms	Maximum value:	5,000 ms	Default value:	200 ms
Description:	This function allows the user to change the timeout of the keypad acknowledgement time. This is the communication performed between the control module and the keypad. This would be adjusted when using long communication cables between drive and a keypad to delay message timeouts. Example: = Transfer delay between the frequency converter and the PC = 600.00 ms. = The value of HMI acknowledge timeout is set to 1200.00 ms (2 x 600.00, sending delay + receiving delay). = The corresponding setting shall be entered in the [Misc]-part of the file. It must also be considered that intervals shorter than the HMI acknowledge timeout time cannot be used in frequency converter drive monitoring.				

Appendix C Parameter Descriptions

P13.2.9	Keypad retry number			ID 634
Minimum value:	1	Maximum value:	10	Default value: 5
Description:	With this parameter you can set the number of times the drive will try to receive acknowledgement when it has not been received within the acknowledgement time (HMI acknowledge timeout) or if the received acknowledgement is faulty.			
P13.3 - User display.				
P13.3.1^②	Output display unit			ID 2424
Minimum value:	N.A.	Maximum value:	N.A.	Default value: 45
Options:	0 = %; 1 = 1/min; 2 = rpm; 3 = ppm; 4 = pps; 5 = l/s; 6 = l/min; 7 = l/h; 8 = kg/s; 9 = kg/min; 10 = kg/h; 11 = m ³ /s; 12 = m ³ /min; 13 = m ³ /h; 14 = m/s; 15 = mbar; 16 = bar; 17 = Pa; 18 = kPa; 19 = mV/s; 20 = kW; 21 = Deg. C; 22 = GPM; 23 = gal/s; 24 = gal/min; 25 = gal/h; 26 = lb/s; 27 = lb/min; 28 = lb/h; 29 = CFM; 30 = ft ³ /s; 31 = ft ³ /min; 32 = ft ³ /h; 33 = ft/s; 34 = in wg; 35 = ft wg; 36 = PSI; 37 = lb/in ² ; 38 = HP; 39 = Deg. F; 40 = PA; 41 = WC; 42 = HG; 43 = ft; 44 = m; 45 = Hz; 46 = strokes/min.			
Description:	Allows for changing the M1.1 and M1.2 value to a desired unit that will reflect the application. From there with P13.3.2 and P13.3.3, it will allow setting a minimum/maximum limit for the value to display desired output.			
P13.3.2^②	Output display unit minimum			ID 2460
Minimum value:	-60,000.00 varies	Maximum value:	OutputDisplayUnitMax varies	Default value: 0.00 varies
Description:	Sets the minimum scaled value when changing the display unit to a value other than the default Hz.			

Appendix C Parameter Descriptions

P13.3.3²	Output display unit maximum			ID 2425
Minimum value:	0 varies	Maximum value:	60,000.00 varies	Default value: MotorNomFreqMFG varies
Description:	Sets the maximum scaled value when changing the display unit to a value other than the default Hz.			
P13.4 - Version information.				
P13.4.1	Keypad software version			ID 640
Minimum value:	N.A.	Maximum value:	N.A.	Default value: N.A.
Description:	Keypad firmware version.			
P13.4.2	Motor control software version			ID 642
Minimum value:	N.A.	Maximum value:	N.A.	Default value: N.A.
Description:	DSP/motor control software version.			
P13.4.3	Application software version			ID 644
Minimum value:	N.A.	Maximum value:	N.A.	Default value: N.A.
Description:	MCU/application software version.			
P13.4.4	Software bundle version			ID 1714
Minimum value:	N.A.	Maximum value:	N.A.	Default value: N.A.
Description:	Software bundle version.			
P13.5 - Application information.				
P13.5.1	Serial number			ID 648
Minimum value:	N.A.	Maximum value:	N.A.	Default value: N.A.
Description:	Product serial number.			
P13.5.2	Multi-monitor set			ID 627
Minimum value:	N.A.	Maximum value:	N.A.	Default value: 0
Options:	0 = Change enable; or 1 = Change disable.			
Description:	The keypad display can display three actual monitored values at the same time. This parameter determines if the operator is allowed to replace the values monitored with other values.			
P13.5.3	Keypad lock PIN			ID 75
Minimum value:	0	Maximum value:	9,999	Default value: 0
Description:	The keypad can be protected against unauthorized changes with the keypad lock function after keys are not pressed five minutes. When the password function is enabled, the user will be prompted to enter a password before the keypad display parameter or response to key press except up/down/left/right. By default, the password function is not in use. If you want to activate the password, change the value of this parameter to any number between 1 and 9,999. To deactivate the password, reset the parameter value to 0.			
P13.5.4	Drive application name			ID 2922
Minimum value:	N.A.	Maximum value:	N.A.	Default value: N.A.
P13.6 - User information.				
P13.6.1	Total MWh count			ID 601
Minimum value:	N.A. MWh	Maximum value:	N.A. MWh	Default value: N.A. MWh
Description:	Megawatt hours total operation time counter of the drive output active.			

Appendix C Parameter Descriptions

System (Cont.).

P13.6.2	Total power day count			ID 603
Minimum value:	N.A.	Maximum value:	N.A.	Default value: N.A.
Description:	Number of days the drive has been supplied with power .			
P13.6.3	Total power hour count			ID 606
Minimum value:	N.A.	Maximum value:	N.A.	Default value: N.A.
Description:	Number of hours the drive has been supplied with power.			
P13.6.4	Total motor hour count			ID 1872
Minimum value:	N.A.	Maximum value:	N.A.	Default value: h
Description:	Number of hours the EVM PRO has been running a motor.			
P13.6.5	Trip MWh count			ID 604
Minimum value:	N.A.	Maximum value:	N.A.	Default value: MWh
Description:	Megawatts hours of the drive output active since last reset.			
P13.6.6	Clear trip MWh count			ID 639
Minimum value:	N.A.	Maximum value:	N.A.	Default value: 0
Options:	0 = Not reset; 1 = Clear trip MWh count; or 2 = Clear trip power count.			
Description:	Resets the day and hour motor or drive running counter and resets the motor run time in the menu.			
P13.6.7	Trip power day count			ID 636
Minimum value:	N.A.	Maximum value:	N.A.	Default value: N.A.
Description:	Number of days since the last reset.			
P13.6.8	Trip power hour count			ID 637
Minimum value:	N.A.	Maximum value:	N.A.	Default value: N.A.
Description:	Number of hours the EVM PRO has been running a motor since the last reset.			

① Parameter value can only be changed after the drive has stopped.

② Parameter value will be set to be default when changing macros.

FR1 mounting instructions

Step 1.

Lift the drive out from the carton and remove the packaging. The magnetic cores and cable ties are only included in EMI version drive.

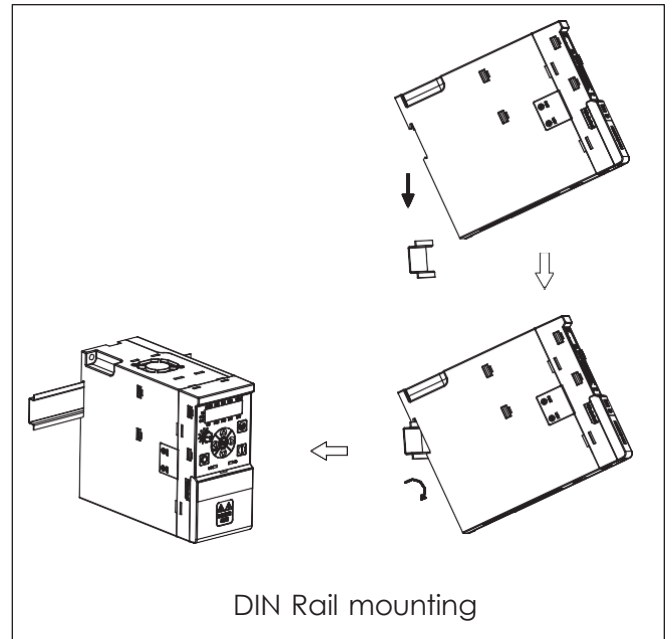
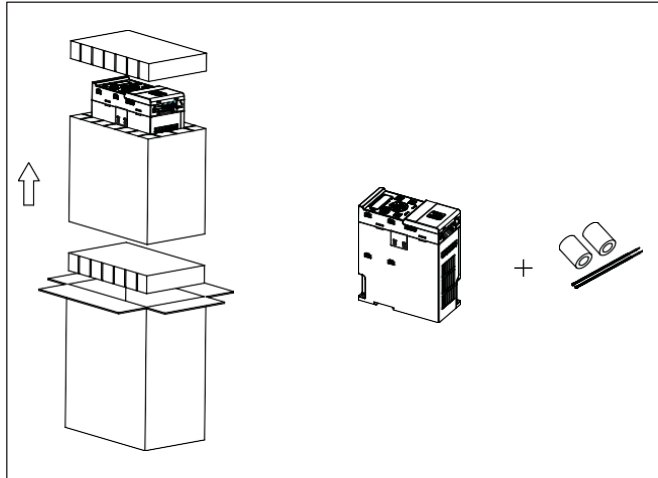

Step 2.

Screw mounting: Attach the drive to the mounting plate with two M5x20 (or 3/16 in.) screws and two M5 (or 3/16 in.) nuts. The opening dimension on the mounting plate should follow required dimension (refer to the dimension drawing in Table 1 of this document).

DIN Rail mounting: Lift the drive at an angle about 30 degrees. Align the top hooks of drive DIN rail mounting slot with DIN rail top edge. Push down and rotate the drive to clip the bottom hooks on the bottom DIN rail edge.

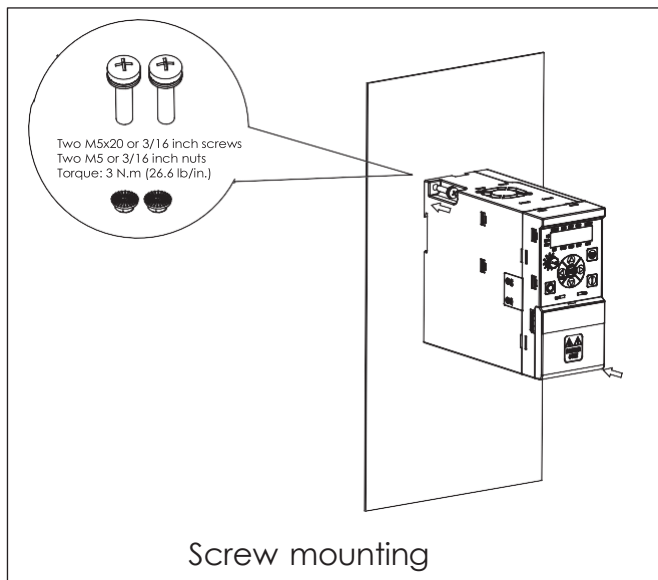

Step 3. (EMI version only):

The input wires (including 3 line wires and 1 input grounding wire) should run through the input magnetic core before connecting to input terminal block and grounding hole. Use a cable tie to tie the input magnetic cores to the input wires. The output wires (only 3 motor wires) should run through the output magnetic core before connecting to output terminal block.

The output grounding wire should not run through the output magnetic core. Use a cable tie to tie the output magnetic cores to the output wires. The maximum distance between input / output magnetic cores top surface and drive bottom surface is 100 mm (3.94 in.). The input magnetic core and output magnetic core are the same for FR1.

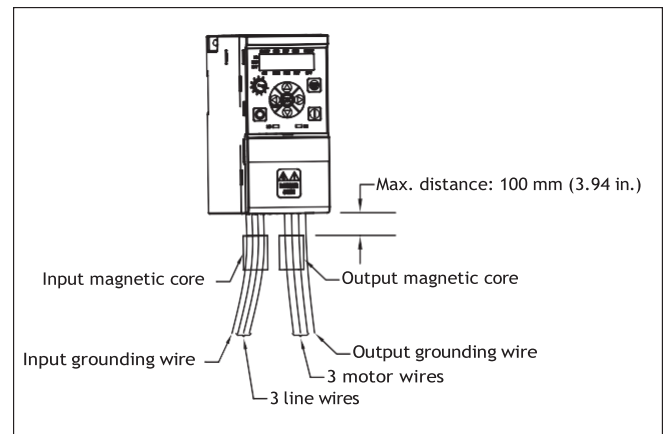

FR2 mounting instructions

Step 1.

Lift the drive out from the carton, remove the packaging. The magnetic cores and cable ties are only included in EMI version drive.

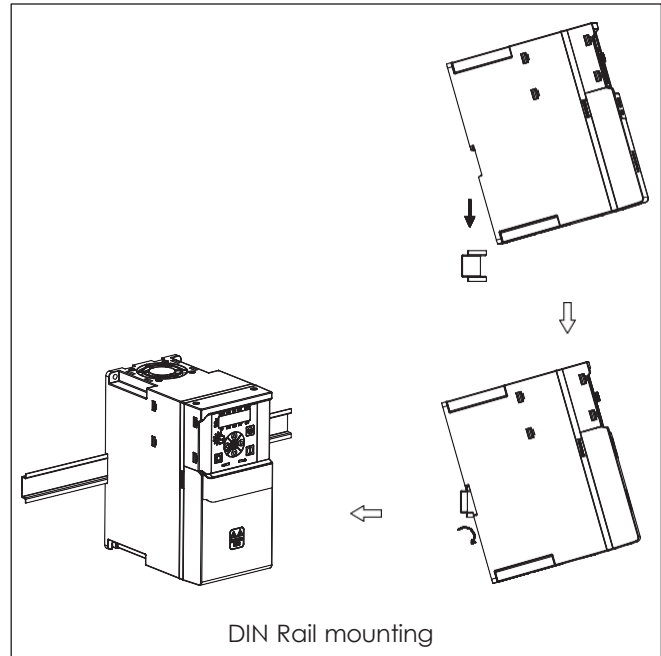
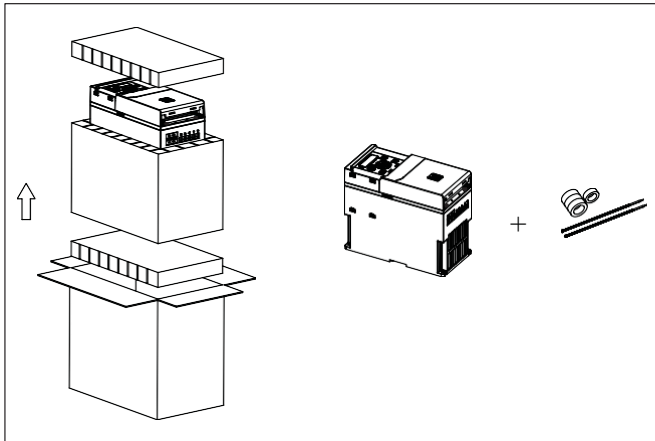

Step 2.

Screw mounting: Attach the drive to the mounting plate with four M5X20 (or 3/16 in.) screws and four M5 (or 3/16 in.) nuts. The opening dimension on the mounting plate should follow required dimension (refer to the dimension drawing in the instruction leaflet).

DIN rail mounting: Lift the drive at an angle about 30 degrees. Align the top hooks of drive DIN rail mounting slot with DIN rail top edge. Push down and rotate the drive to clip the bottom hooks on the bottom DIN rail edge.

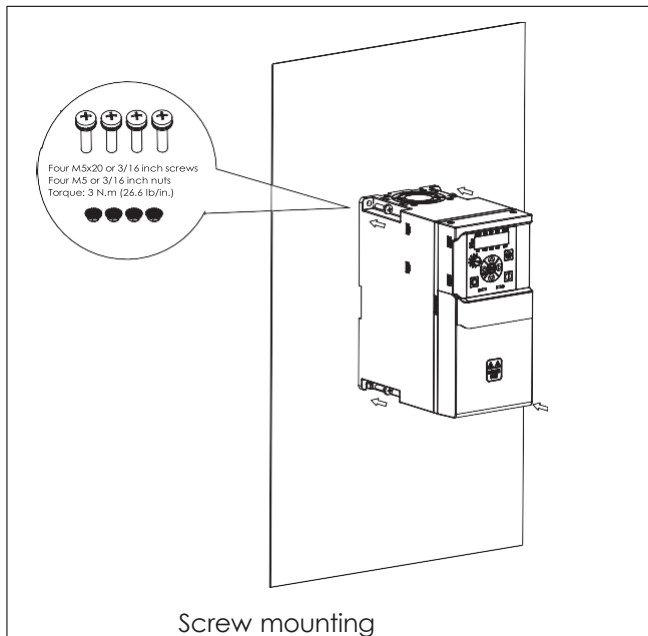

Step 3. (EMI version only):

The input wires (including three line wires and one input grounding wire) should run through the input magnetic core before connecting to input terminal block and grounding. Use a cable tie to secure the input magnetic cores to the input wires.

The output wires (only three motor wires) should run through the output magnetic core before connecting to output terminal block. The output grounding wire should **not** run through the output magnetic core. Use a cable tie to secure the output magnetic cores to the output wires.

The max distance between input/output magnetic cores top surface and drive bottom surface is 100 mm (3.94 in.).

The height of the input magnetic core is bigger than output magnetic core for 3-phase FR2 EMI version, but they are the same for 1-phase FR2 EMI version.

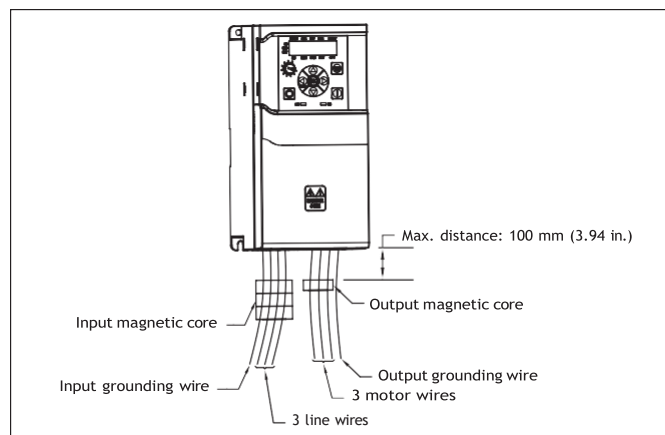

FR3 mounting instructions

Step 1.

Lift the drive out from the carton, remove the packaging. The magnetic cores and cable ties are only included in EMI version drive.

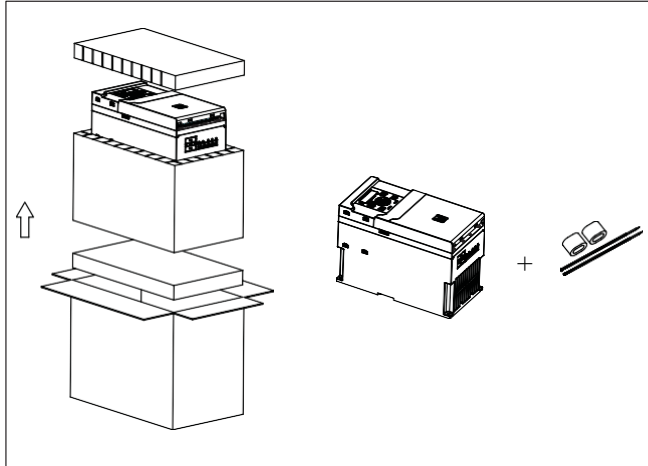

Step 2.

Screw mounting: Attach the drive to the mounting plate with four M5X20 (or 3/16 in.) screws and four M5 (or 3/16 in.) nuts. The opening dimension on the mounting plate should follow required dimension (refer to the dimension drawing in the instruction leaflet).

DIN Rail mounting: Lift the drive at an angle about 30 degrees. Align the top hooks of drive DIN rail mounting slot with DIN rail top edge. Push down and rotate the drive to clip the bottom hooks on the bottom DIN rail edge.

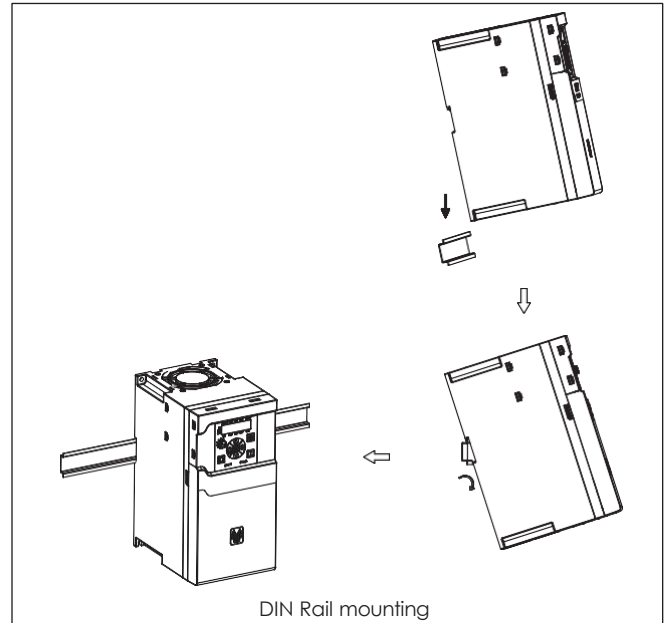
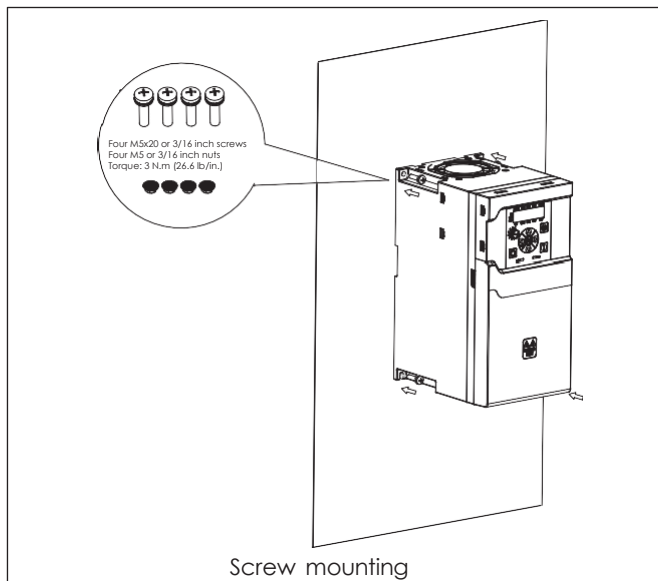

Step 3. (EMI version only):

The input wires (including three line wires and one input grounding wire) should run through the input magnetic core before connecting to the input terminal block and grounding hole. Use a cable tie to secure the input magnetic cores to the input wires.

For 3-phase FR3 EMI version, the output wires (only three motor wires) should run through the output magnetic core before connecting to output terminal block. The output grounding wire should **not** run through the output magnetic core. Use a cable tie to secure the output magnetic cores to the output wires.

For the 1-phase FR3 EMI version, there is no output magnetic core. The motor wires and output grounding wire can be connected to corresponding terminals directly.

The max distance between input/output magnetic cores top surface and drive bottom surface is 100 mm (3.94 in.). The input magnetic core and output magnetic core are the same for 3-phase FR3 EMI version.

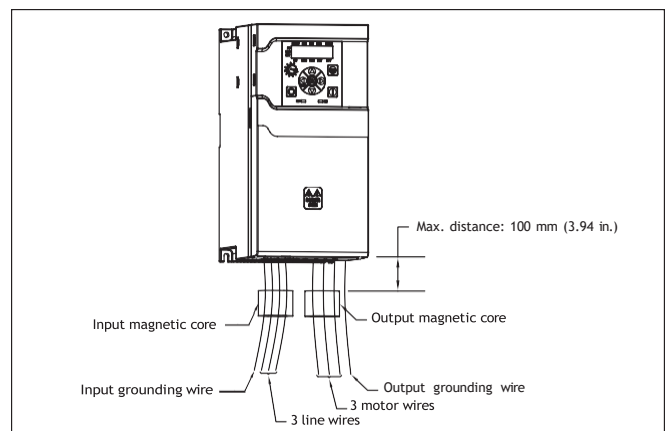

FR4 mounting instructions

Step 1.

Lift the drive out from the carton, remove the packaging. The magnetic cores and cable ties are only included in EMI version drive.

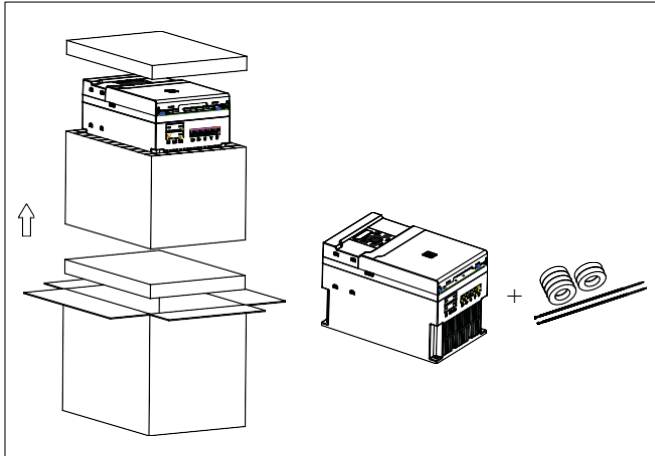

Step 2.

Screw mounting: Attach the drive to the mounting plate with four M5x20 (or 3/16 in.) screws and four M5 (or 3/16 in.) nuts. The opening dimension on the mounting plate should follow required dimension (refer to the dimension drawing in the instruction leaflet).

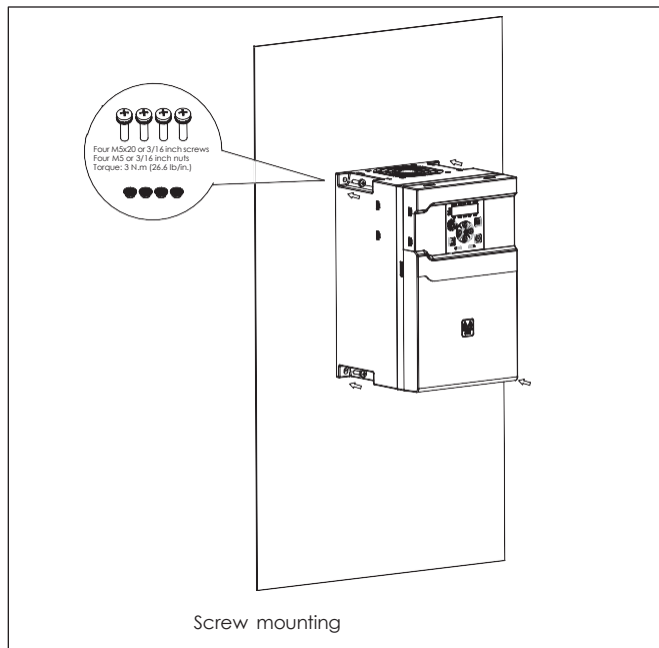

Step 3. (EMI version only):

The input wires (including 3 line wires and 1 input grounding wire) should run through the input magnetic core before connecting to input terminal block and grounding hole. Use a cable tie to tie the input magnetic cores to the input wires. The output wires (only 3 motor wires) should run through the output magnetic core before connecting to output terminal block.

The output grounding wire should not run through the output magnetic core. Use a cable tie to tie the output magnetic cores to the output wires. The maximum distance between input / output magnetic cores top surface and drive bottom surface is 100 mm (3.94 in.). The height of input magnetic core is bigger than output magnetic core for FR4. .

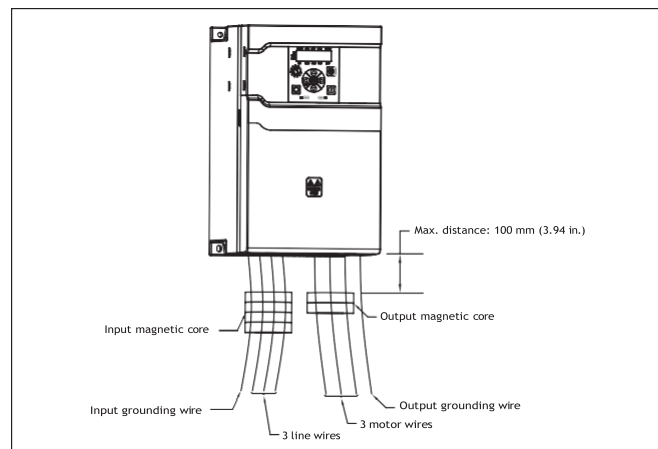

NEMA 1/IP21 Kit

For Copeland™ Commercial HVACR
EVM Variable Frequency Drive

Component list for EVM drive with NEMA 1 kit

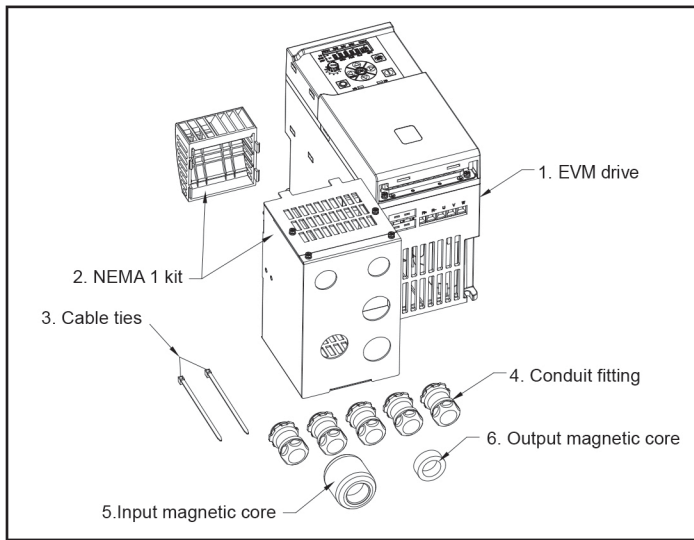

1. EVM drive.
2. NEMA 1 kit (with fan cover).
3. Cable tie (2 pcs., shipped with drive for EMI version only).
4. Conduit fitting (prepared by customer).
5. Input magnetic core (shipped with drive for EMI version only).
6. Output magnetic core (shipped with drive for EMI version only).
7. Input/output/grounding cable etc.

Note: The input magnetic core and output magnetic core are the same for FR1 and FR3, while the height for input magnetic core is bigger than output magnetic core for FR2 and FR4.

Part Number	
FR1.....	962-0009-00
FR2.....	962-0010-00
FR3.....	962-0011-00
FR4.....	962-0012-00

Component list for EVM NEMA 1 kit

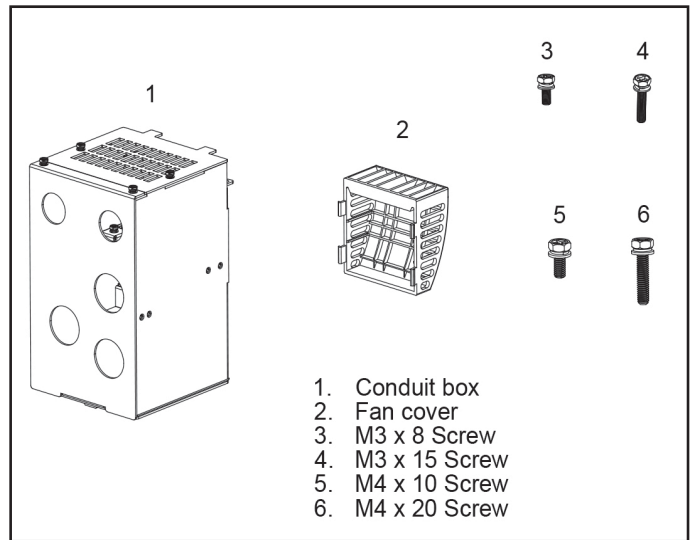

Table 1 - Screw quantities

	MC x 8	M3 x 15	M4 x 10	M4 x 20
FR1	6	2		
FR2	6			2
FR3	4		2	2
FR4			6	2

Table 2 - MOV/EMC Screw Torques

	N·m	inch-lb
FR1	0.8	7.1
FR2	0.8	7.1
FR3	0.8	7.1
FR4	0.8	7.1

Appendix D: Mounting and NEMA 1 kit Installation

Installation steps for EVM FR1-4 NEMA 1 kit

Step 1

Insert the two hooks on thinner end of fan cover into the two slots on top surface of drive first (refer to detail A), then push the two hooks on thicker end of fan cover into the two slots on top surface of drive. The thicker end of the fan cover should face the front surface of drive.

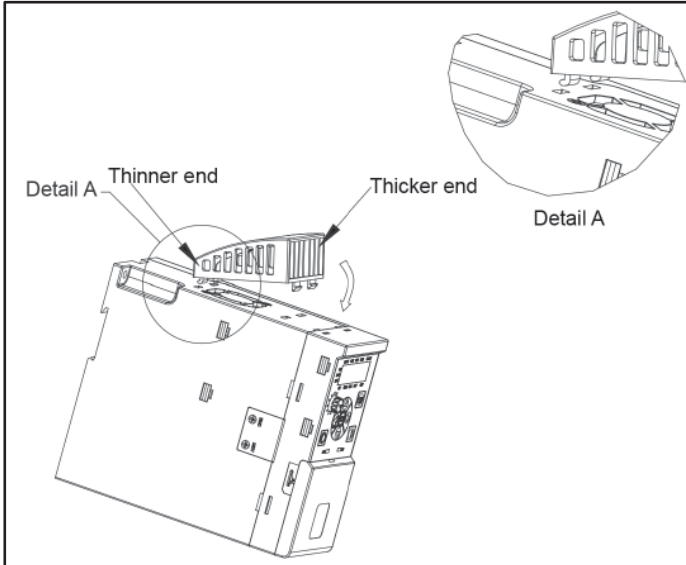

1. VM drive.
2. NEMA 1 kit (with a cover).
3. Cable tie (2s., shipped with drive for EMI version only).
4. Conduit fitting (prepared by customer).
5. Input magnetic core (shipped with drive for EMI version only).
6. Output magnetic core (shipped with drive for EMI version only).
7. Input/output/grounding cable tc.

Note: The input magnetic core and output magnetic core are the same for FR1 and FR3, while the height for input magnetic core is bigger than output magnetic core for FR2 and FR4.

Step 2

Remove the two screws ③, NEMA 1 kit front cover ①, and terminal cover ② (See A).

Remove the two screws ④, NEMA 1 kit left cover ⑤, and NEMA 1 kit right plate ⑥ (See B)

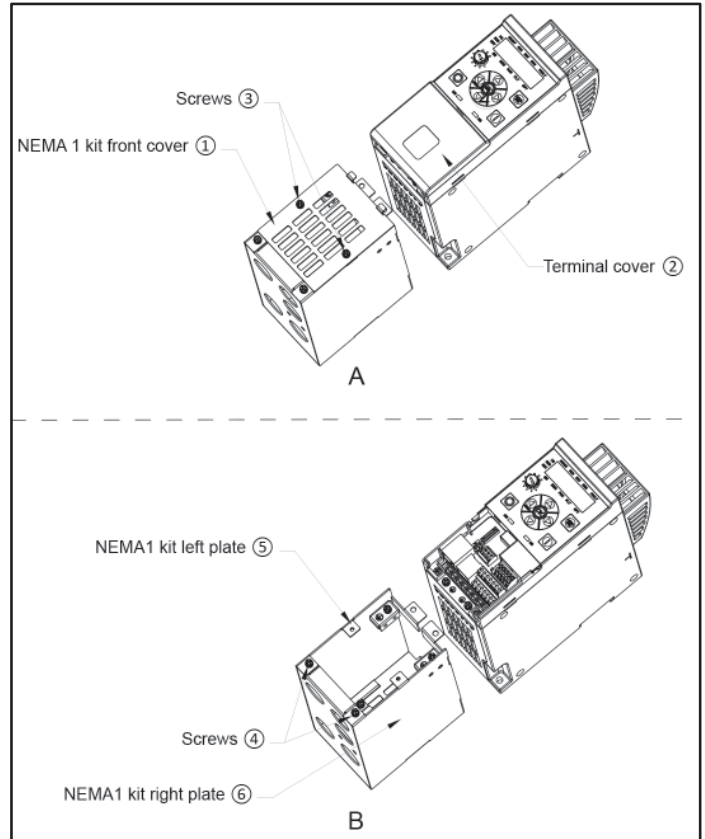

Step 3

Mount the conduit fittings ⑧⑨ on the NEMA 1 kit main frame

⑦. Then insert the hooks on bottom plate into the corresponding rectangular openings on drive bottom surface.

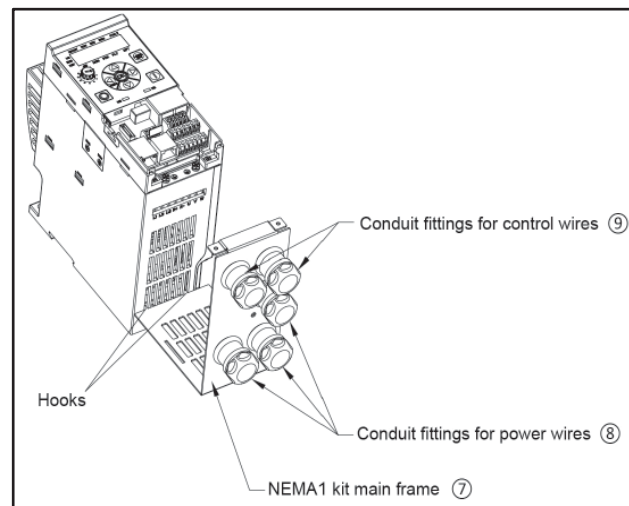

Table 3 - Conduit fitting for wires

	Control wires	Power wires
FR1	0.5 inch, 2 pcs.	0.5 inch, 3 pcs.
FR2	0.5 inch, 2 pcs.	0.75 inch, 3 pcs.
FR3	0.5 inch, 2 pcs.	0.75 inch, 3 pcs.
FR4	0.5 inch, 2 pcs.	1.0 inch, 3 pcs.

Appendix D: Mounting and NEMA 1 kit Installation

Step 4

Power wiring for EMI version drive:

1. Run input cable (including three-line wires and one input grounding wire) through conduit fitting and input magnetic core ⑩, then connect to L1/L2/L3 terminals, leave the input grounding wire ⑪ unconnected. Tie the input magnetic core to the input wires with a cable tie (See A).
2. Run the output cable (including three motor wires and one output grounding wire) through conduit fitting and EMC grounding clamp ⑩. Run the three motor wires without the output grounding wire through the output magnetic core ⑫. Connect the motor wires to U/V/W terminals. Leave the output grounding wire ⑬ unconnected. Tie output magnetic core to the output wires with a cable tie. Use the EMC grounding clamp ⑩ and two screws ⑭ to fix output cable shielding layer (See B).

Power wiring for non-EMI version drive:

1. Run input cable (including three-line wires and one input grounding wire) through conduit fitting. Connect to L1/L2/L3 terminals. Leave the input grounding wire ⑪ unconnected.
2. Run the output cable (including three motor wires and one output grounding wire) through conduit fitting and EMC grounding clamp ⑩. Connect the motor wires to U/V/W terminals. Leave the output grounding wire ⑬ unconnected. Use the EMC grounding clamp ⑩ and two screws ⑭ to fix output cable shielding layer.

Control wiring:

1. Run control wires (RJ45, ethernet, I/O, STO, relay, etc.) through control wire conduit fittings ⑯ and connect to corresponding terminals or connectors.

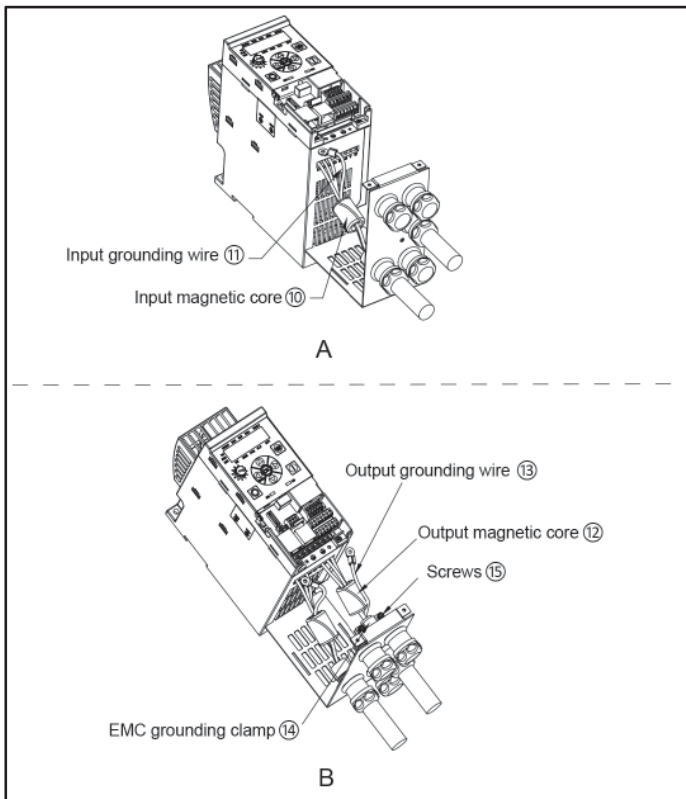

Step 5

Mount the NEMA 1 kit bottom plate ⑤ back to the NEMA 1 kit main frame ⑦ with two screws ④.

Mount the terminal cover ② back to the drive. Mount NEMA 1 kit front cover ① back to the NEMA 1 kit main frame ⑦ with two screws ③.

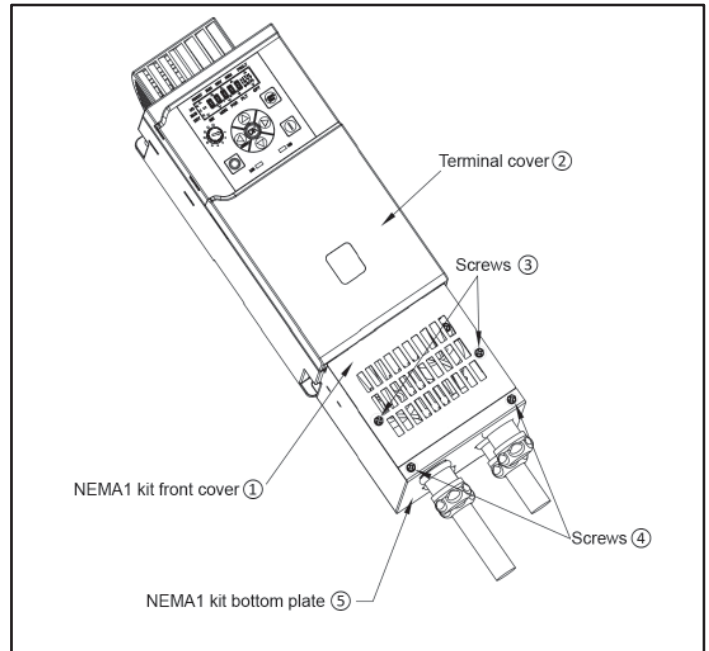

Appendix E: Cable and Fuse Sizing Guidelines

Stripping lengths.

Frame size	Power wiring				Motor wiring			
	A1 in. (mm)	B1 in. (mm)	C1 in. (mm)	D1 in. (mm)	A2 in. (mm)	B2 in. (mm)	C2 in. (mm)	D2 in. (mm)
FR1	0.39 (10)	2.76 (70)	0.39 (10)	2.76 (70)	0.39 (10)	2.76 (70)	0.39 (10)	2.76 (70)
FR2	0.47 (12)	2.76 (70)	0.47 (12)	2.76 (70)	0.47 (12)	2.76 (70)	0.47 (12)	2.76 (70)
FR3	0.47 (12)	3.54 (90)	0.47 (12)	3.54 (90)	0.47 (12)	3.54 (90)	0.47 (12)	3.54 (90)
FR4	0.79 (20)	4.53 (115)	0.79 (20)	4.53 (115)	0.79 (20)	4.53 (115)	0.79 (20)	4.53 (115)

Note: For I/O/STO/relay output wires, the stripping lengths = 0.236 in (6-7 mm)

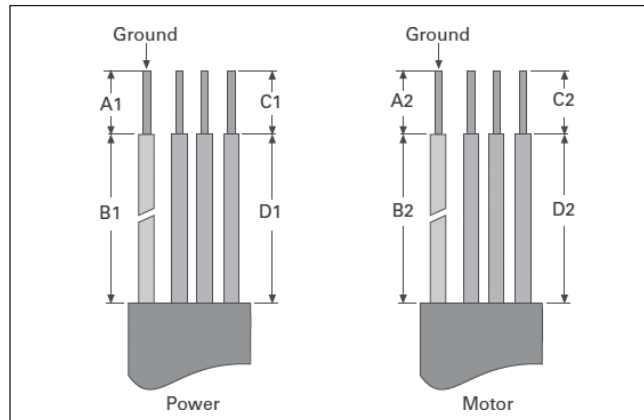

Connection sizes and torques.①②③

Input voltage	Frame size	Drive Model number	Output rating		Size and torque				Control wire torque in.-lb (N·m) AI/DI	RO
			Amps	Power wire size AWG (mm²)	Power wire torque in.-lb (N·m)	Ground wire size AWG (mm²)	Ground wire torque in.-lb (N·m)	Control wire size AWG (mm²)		
100 Vac to 120 Vac 50/60 Hz 1-phase	FR1	EVM1122D5	2.5	14 (2.5)	4.4 (0.5)	10 (2.5)	7.1 (0.8)	28-16 (0.5-1.5)	1.73 (0.2)	4.5 (0.5)
		EVM1124D8	4.8	10 (6)	4.4 (0.5)	8 (6)	7.1 (0.8)	28-16 (0.5-1.5)	1.73 (0.2)	4.5 (0.5)
	FR2	EVM1126D9	6.9	8 (10)	10.5 (1.2)	8 (10)	7.1 (0.8)	28-16 (0.5-1.5)	1.73 (0.2)	4.5 (0.5)
		EVM1127D8	7.8	8 (10)	10.5 (1.2)	6 (10)	7.1 (0.8)	28-16 (0.5-1.5)	1.73 (0.2)	4.5 (0.5)
200 Vac to 240 Vac 50/60 Hz 1-phase"	FR1	EVM1222D5	2.5	14 (2.5)	4.4 (0.5)	14 (2.5)	7.1 (0.8)	28-16 (0.5-1.5)	1.73 (0.2)	4.5 (0.5)
		EVM1224D8	4.8	14 (2.5)	4.4 (0.5)	10 (2.5)	7.1 (0.8)	28-16 (0.5-1.5)	1.73 (0.2)	4.5 (0.5)
		EVM1227D8	7.8	10 (6)	4.4 (0.5)	8 (6)	7.1 (0.8)	28-16 (0.5-1.5)	1.73 (0.2)	4.5 (0.5)
	FR2	EVM122011	11	10 (6)	10.5 (1.2)	8 (6)	7.1 (0.8)	28-16 (0.5-1.5)	1.73 (0.2)	4.5 (0.5)
		EVM122017	17.5	8 (10)	10.5 (1.2)	6 (10)	7.1 (0.8)	28-16 (0.5-1.5)	1.73 (0.2)	4.5 (0.5)
		FR3	EVM122025	25.3	6 (16)	10.5 (1.2)	6 (16)	14.2 (1.6)	28-16 (0.5-1.5)	1.73 (0.2)
200 Vac to 240 Vac 50/60 Hz 3-phase	FR1	EVM3222D5	2.5	14 (2.5)	4.4 (0.5)	14 (2.5)	7.1 (0.8)	28-16 (0.5-1.5)	1.73 (0.2)	4.5 (0.5)
		EVM3224D8	4.8	14 (2.5)	4.4 (0.5)	14 (2.5)	7.1 (0.8)	28-16 (0.5-1.5)	1.73 (0.2)	4.5 (0.5)
		EVM3227D8	7.8	14 (2.5)	4.4 (0.5)	12 (2.5)	7.1 (0.8)	28-16 (0.5-1.5)	1.73 (0.2)	4.5 (0.5)
		EVM322011	11	12 (4)	4.4 (0.5)	10 (4)	7.1 (0.8)	28-16 (0.5-1.5)	1.73 (0.2)	4.5 (0.5)
	FR2	EVM322017	17.5	10 (6)	10.5 (1.2)	10 (6)	7.1 (0.8)	28-16 (0.5-1.5)	1.73 (0.2)	4.5 (0.5)
		EVM322025	25.3	8 (10)	10.5 (1.2)	10 (10)	7.1 (0.8)	28-16 (0.5-1.5)	1.73 (0.2)	4.5 (0.5)
	FR3	EVM322032	32.2	8 (10)	10.5 (1.2)	8 (10)	14.2 (1.6)	28-16 (0.5-1.5)	1.73 (0.2)	4.5 (0.5)
	FR4	EVM322048	48.3	4 (25)	33 (3.73)	8 (16)	14.2 (1.6)	28-16 (0.5-1.5)	1.73 (0.2)	4.5 (0.5)
		EVM322062	62.1	3 (35)	33 (3.73)	6 (16)	14.2 (1.6)	28-16 (0.5-1.5)	1.73 (0.2)	4.5 (0.5)

Appendix E: Cable and Fuse Sizing Guidelines

Connection sizes and torques.①②③

Input voltage	Frame size	Drive model number	Output rating	Size and torque			Control wire size AWG (mm²)	Control wire torque in.-lb (N·m) AI/DI	RO	
			Amps	Power wire size AWG (mm²)	Power wire torque in.-lb (N·m)	Ground wire size AWG (mm²)				Ground wire torque in.-lb (N·m)
380 Vac to 460 Vac 50/60 Hz 3-phase	FR1	EVM3442D2	2.2	14 (2.5)	4.4 (0.5)	14 (2.5)	7.1 (0.8)	28-16 (0.5-1.5)	1.73 (0.2) 4.5 (0.5)	
		EVM3444D3	4.3	14 (2.5)	4.4 (0.5)	14 (2.5)	7.1 (0.8)	28-16 (0.5-1.5)	1.73 (0.2) 4.5 (0.5)	
		EVM3445D6	5.6	14 (2.5)	4.4 (0.5)	14 (2.5)	7.1 (0.8)	28-16 (0.5-1.5)	1.73 (0.2) 4.5 (0.5)	
		EVM3447D6	7.6	14 (2.5)	4.4 (0.5)	10 (2.5)	7.1 (0.8)	28-16 (0.5-1.5)	1.73 (0.2) 4.5 (0.5)	
	FR2	EVM344012	12	12 (4)	10.5 (1.2)	10 (4)	7.1 (0.8)	28-16 (0.5-1.5)	1.73 (0.2) 4.5 (0.5)	
		EVM344016	16	10 (6)	10.5 (1.2)	10 (6)	7.1 (0.8)	28-16 (0.5-1.5)	1.73 (0.2) 4.5 (0.5)	
		EVM344023	23	8 (10)	10.5 (1.2)	10 (10)	7.1 (0.8)	28-16 (0.5-1.5)	1.73 (0.2) 4.5 (0.5)	
	FR3	EVM344031	31	8 (10)	10.5 (1.2)	8 (10)	14.2 (1.6)	28-16 (0.5-1.5)	1.73 (0.2) 4.5 (0.5)	
	FR4	EVM344038	38	6 (16)	33 (3.73)	8 (16)	14.2 (1.6)	28-16 (0.5-1.5)	1.73 (0.2) 4.5 (0.5)	
		EVM344046	46	4 (25)	33 (3.73)	8 (16)	14.2 (1.6)	28-16 (0.5-1.5)	1.73 (0.2) 4.5 (0.5)	
	525 Vac to 600 Vac 50/60 Hz 3-phase	FR2	EVM3557D5	7.5	14 (2.5)	10.5 (1.2)	10 (2.5)	7.1 (0.8)	28-16 (0.5-1.5)	1.73 (0.2) 4.5 (0.5)
			EVM355010	10	14 (2.5)	10.5 (1.2)	10 (2.5)	7.1 (0.8)	28-16 (0.5-1.5)	1.73 (0.2) 4.5 (0.5)
EVM355013			13.5	10 (6)	10.5 (1.2)	10 (6)	7.1 (0.8)	28-16 (0.5-1.5)	1.73 (0.2) 4.5 (0.5)	
FR3		EVM355018	18	10 (6)	10.5 (1.2)	8 (6)	14.2 (1.6)	28-16 (0.5-1.5)	1.73 (0.2) 4.5 (0.5)	
FR4		EVM355022	22	8 (10)	33 (3.73)	8 (10)	14.2 (1.6)	28-16 (0.5-1.5)	1.73 (0.2) 4.5 (0.5)	
		EVM355027	27	8 (10)	33 (3.73)	8 (10)	14.2 (1.6)	28-16 (0.5-1.5)	1.73 (0.2) 4.5 (0.5)	

Notes:

- ① Line and motor cable size is selected according to UL 61800-5-1 for copper conductor rated 75°C. Use only with copper wire rated 75°C here. Size requirements for other different wire types are defined in the National Electrical Code®, ANSI/NFPA® 70.
- ② Earthing conductor size is determined by the maximum overcurrent device rating used ahead of the drive according to UL 61800-5-1.
- ③ If power cubes or bypass are used, a UL listed Class J, T, CF, CC or equivalent fuse is recommended.

Appendix E: Cable and Fuse Sizing Guidelines

Cable and fuse guidelines

North America cable and fuse sizes. ①②④

UL cable and fuse sizes

Input voltage	Frame size	Drive model number	Output rating		Input rating		UL application					
			Amps	Amps	Recommended fuse (max. rating) 100 kAIC ^③	Recommended miniature circuit breaker (max. rating) 10/14 kAIC	Recommended type E CMC (max. Rating) 65 kAIC	Recommended circuit breaker (max. rating) 100 kAIC (Open type only for 3 phase. Enclosed type for 1 phase.)	NEC wire size line and motor AWG	NEC wire size ground AWG	Terminal size line and motor AWG	Terminal size ground AWG
100 Vac to 120 Vac	FR1	EVM1122D5	2.5	10	30	30	\	30	14	10	18-8	16-8
		EVM1124D8	4.8	20	70	63	\	70	10	8	18-8	16-8
	FR2	EVM1126D9	6.9	26.4	90	63	\	90	8	8	20-6	12-6
50/60 Hz 1-phase		EVM1127D8	7.8	30	125	63	\	125	8	6	20-6	12-6
	FR1	EVM1222D5	2.5	6.5	15	15	\	15	14	14	18-8	16-8
EVM1224D8		4.8	11	30	30	\	30	14	10	18-8	16-8	
EVM1227D8		7.8	17	60	63	\	60	10	8	18-8	16-8	
50/60 Hz 1-phase	FR2	EVM122011	11	23	80	63	\	80	10	8	20-6	12-6
		EVM122017	17.5	35	125	63	\	125	8	6	20-6	12-6
	FR3	EVM122025	25.3	49.6	200	\	\	200	6	6	20-6	8-6
200 Vac to 240 Vac 50/60 Hz 3-phase	FR1	EVM3222D5	2.5	3.3	6	5	6.3	15	14	14	18-8	16-10
		EVM3224D8	4.8	5.8	15	10	6.3	15	14	14	18-8	16-10
		EVM3227D8	7.8	9.4	20	15	10	15	14	12	18-8	16-10
	FR2	EVM322011	11	13.2	30	20	16	20	12	10	18-8	16-10
		EVM322017	17.5	20.1	40	30	25	30	10	10	20-6	12-8
		EVM322025	25.3	29.1	60	40	32	45	8	10	20-6	12-8
	FR3	EVM322032	32.2	37	70	50	40	50	8	8	20-6	10-8
		FR4	EVM322048	48.3	53.1	100	\	\	80	4	8	20-2
	EVM322062		62.1	68.3	125	\	\	100	3	6	20-2	8-6
380 Vac to 460 Vac 50/60 Hz 3-phase	FR1		EVM3442D2	2.2	2.6	6	4	6.3	15	14	14	18-8
		EVM3444D3	4.3	5.2	10	8	6.3	15	14	14	18-8	16-10
		EVM3445D6	5.6	6.7	15	10	10	15	14	14	18-8	16-10
	FR2	EVM3447D6	7.6	9.1	30	15	10	15	14	10	18-8	16-10
		EVM344012	12	14.4	30	20	16	20	12	10	20-6	12-8
		EVM344016	16	19.2	40	25	25	30	10	10	20-6	12-8
FR3	EVM344023	23	27.6	60	32	32	40	8	10	20-6	12-8	
	EVM344031	31	35.7	70	\	40	50	8	8	20-6	10-8	
FR4	EVM344038	38	43.7	70	\	50	70	6	8	20-2	8-6	
	EVM344046	46	52.9	80	\	58	80	4	8	20-2	8-6	
525 Vac to 600 Vac 50/60 Hz 3-phase	FR2	EVM3557D5	7.5	9	30	\	10	\	14	10	20-6	12-8
		EVM355010	10	12	40	\	16	\	14	10	20-6	12-8
		EVM355013	13.5	16.2	50	\	25	\	10	10	20-6	12-8
	FR3	EVM355018	18	21.6	70	\	25	\	10	8	20-6	10-8
		FR4	EVM355022	22	26.4	80	\	32	\	8	8	20-2
	EVM355027		27	32.4	100	\	40	\	8	8	20-2	8-6

Notes:

- ① Line and motor cable size is selected according to UL 61800-5-1 for copper conductor rated 75°C. Use only with copper wire rated 75°C here. Size requirements for other different wire types are defined in the National Electrical Code®, ANSI/NFPA® 70.
- ② Earthing conductor size is determined by the maximum overcurrent device rating used ahead of the drive according to UL 61800-5-1.
- ③ If power cubes or bypass are used, a UL listed Class J, T, CF, CC or equivalent fuse is recommended.

Appendix E: Cable and Fuse Sizing Guidelines

International cable and fuse sizes. ① ②

IEC cable and fuse sizes

		Output rating		Input rating		IEC application						
Input voltage	Frame size	Drive model number	Amps	Amps	Recommended fuse (max. rating) 100 kAIC ^③	Recommended miniature circuit breaker (max. rating) 10/14 kAIC	Recommended Type E CMC (max. rating) 65 kAIC	Recommended circuit breaker (max. rating) 100 kAIC (Open type only for 3 phase. enclosed type will be ok.)	IEC cable size line and motor mm ²	IEC cable size ground mm ²	Terminal size line and motor mm ²	Terminal size ground mm ²
100 Vac to 120 Vac 50/60 Hz 1-phase	FR1	EVM1122D5	2.5	10	30	30	\	30	2.5	2.5	0.2-6	1-6
		EVM1124D8	4.8	20	70	63	\	70	6	6	0.2-6	1-6
	FR2	EVM1126D9	6.9	26.4	90	63	\	90	10	10	0.5-16	1-10
		EVM1127D8	7.8	30	125	63	\	125	10	10	0.5-16	1-10
200 Vac to 240 Vac 50/60 Hz 1-phase	FR1	EVM1222D5	2.5	6.5	15	15	\	15	2.5	2.5	0.2-6	1-6
		EVM1224D8	4.8	11	30	30	\	30	2.5	2.5	0.2-6	1-6
		EVM1227D8	7.8	17	60	63	\	60	6	6	0.2-6	1-6
	FR2	EVM122011	11	23	80	63	\	80	6	6	0.5-16	1-10
		EVM122017	17.5	35	125	63	\	125	10	10	0.5-16	1-10
		FR3	EVM122025	25.3	49.6	200	\	\	200	16	16	0.5-16
200 Vac to 240 Vac 50/60 Hz 3-phase	FR1	EVM3222D5	2.5	3.3	6	5	6.3	15	2.5	2.5	0.2-6	1.5-6
		EVM3224D8	4.8	5.8	15	10	6.3	15	2.5	2.5	0.2-6	1.5-6
		EVM3227D8	7.8	9.4	20	15	10	15	2.5	2.5	0.2-6	1.5-6
	FR2	EVM322011	11	13.2	30	20	16	20	4	4	0.2-6	1.5-6
		EVM322017	17.5	20.1	40	30	25	30	6	6	0.5-16	4-10
	FR3	EVM322025	25.3	29.1	60	40	32	45	10	10	0.5-16	4-10
		EVM322032	32.2	37	70	50	40	50	10	10	0.5-16	6-10
	FR4	EVM322048	48.3	53.1	100	\	\	80	25	16	0.5-35	10-16
		EVM322062	62.1	68.3	125	\	\	100	35	16	0.5-35	10-16
		380 Vac to 460 Vac 50/60 Hz 3-phase	FR1	EVM3442D2	2.2	2.6	6	4	6.3	15	2.5	2.5
EVM3444D3	4.3			5.2	10	8	6.3	15	2.5	2.5	0.2-6	1.5-6
FR2	EVM3445D6		5.6	6.7	15	10	10	15	2.5	2.5	0.2-6	1.5-6
	EVM3447D6		7.6	9.1	30	15	10	15	2.5	2.5	0.2-6	1.5-6
	EVM344012		12	14.4	30	20	16	20	4	4	0.5-16	4-10
FR3	EVM344016		16	19.2	40	25	25	30	6	6	0.5-16	4-10
	EVM344023		23	27.6	60	32	32	40	10	10	0.5-16	4-10
FR4	EVM344031	31	35.7	70	\	40	50	10	10	0.5-16	6-10	
525 Vac to 600 Vac 50/60 Hz 3-phase	FR2	EVM344038	38	43.7	70	\	50	70	16	16	0.5-35	10-16
		EVM344046	46	52.9	80	\	58	80	25	16	0.5-35	10-16
525 Vac to 600 Vac 50/60 Hz 3-phase	FR2	EVM3557D5	7.5	9	30	\	10	\	2.5	2.5	0.5-16	2.5-10
		EVM355010	10	12	40	\	16	\	2.5	2.5	0.5-16	2.5-10
		EVM355013	13.5	16.2	50	\	25	\	6	6	0.5-16	4-10
	FR3	EVM355018	18	21.6	70	\	25	\	6	6	0.5-16	6-10
	FR4	EVM355022	22	26.4	80	\	32	\	10	10	0.5-35	10-16
		EVM355027	27	32.4	100	\	40	\	10	10	0.5-35	10-16

Notes:

- ① Line and motor cable size is selected according to IEC 60364-5-52 for copper conductor with PVC insulation with a wiring condition of ambient temperature 30°C in air and an installation method of “B2” (cables in conduit and cable trunking systems). For other wiring conditions, please refer to the standard of IEC 60364-5-52:2009 or suitable cable sizes.
- ② Earthing conductor size is determined by the cross-sectional area of phase conductors according to IEC/EN 61800-5-1. So if phase conductor size is changed, earthing conductor size should also be changed accordingly.
- ③ If power cubes or bypass are used, a class gG/gL fuse is recommended.

Appendix E: Cable and Fuse Sizing Guidelines

The input current scaling describes what the input current will be if an undersized motor is applied to the drive. This allows for smaller cables and circuit protection where oversized drives are used. Three options are provided to allow flexibility in installations.

Input Voltage	Frame Size	Drive Model Number	Output rating				Input Rating				
			Max Rating VT/I _L Current Amps	Option 1 VT/I _L Current Amps	Option 2 VT/I _L Current Amps	Option 3 VT/I _L Current Amps	Max Rating VT/I _L Current Amps	Option 1 VT/I _L Current Amps	Option 2 VT/I _L Current Amps	Option 3 VT/I _L Current Amps	
100 Vac to 120 Vac 50/60 Hz 1-phase	FR1	EVM1122D5	2.5	1.6	1.3	1	10	6.4	5.2	4	
		EMV1124D8	4.8	2.5	1.6	1.3	20	11.3	7.2	5.9	
	FR2	EVM1126D9	6.9	4.8	2.5	1.6	26.4	20	10.4	6.7	
		EVM1127D8	7.8	6.9	4.8	2.5	30	26.4	18.4	9.6	
200 Vac to 240 Vac 50/60 Hz 1-phase	FR1	EVM1222D5	2.5	1.6	1.3	1	6.5	4	3.3	2.5	
		EVM1224D8	4.8	2.5	1.6	1.3	11	6.7	4.3	3.5	
		EVM1227D8	7.8	4.8	2.5	1.6	17	11	5.7	3.7	
	FR2	EVM122011	11	7.8	4.8	2.5	23	18	11.1	5.8	
		EVM122017	17.5	11	7.8	4.8	35	23	16.3	10	
		EVM122025	25.3	17.5	11	7.8	49.6	38	23.9	16.9	
200 Vac to 240 Vac 50/60 Hz 3-phase	FR1	EVM3222D5	2.5	1.6	1.3	1	3.3	2.1	1.7	1.3	
		EVM3224D8	4.8	2.5	1.6	1.3	5.8	3.3	2.1	1.7	
		EVM3227D8	7.8	4.8	3	1.6	9.4	5.8	3	1.9	
		EVM322011	11	7.8	4.8	2.5	13.2	9.4	5.8	3	
	FR2	EVM322017	17.5	11	7.8	4.8	20.1	12.7	9	5.5	
		EVM322025	25.3	17.5	11	7.8	29.1	20.1	12.6	9	
	FR3	EVM322032	32.2	25.3	17.5	11	37	29.1	20.1	12.7	
	FR4	EVM322048	48.3	32.2	25.3	17.5	53.1	35.4	27.8	19.2	
EVM322062		62.1	48.3	32.2	25.3	68.3	53.1	35.4	27.8		
380 Vac to 480 Vac 50/60 Hz 3-phase	FR1	EVM3442D2	2.2	1.5	1.1	0.9	2.6	1.8	1.3	1.1	
		EVM3444D3	4.3	2.2	1.5	1.1	5.2	2.6	1.8	1.3	
		EVM3445D6	5.6	4.3	2.2	1.5	3.7	5.2	2.7	1.8	
		EVM3447D6	7.6	5.6	4.3	2.2	9.1	6.7	5.1	2.6	
		FR2	EVM344012	12	7.6	5.6	4.3	14.4	9.1	6.7	5.1
			EVM344016	16	12	7.6	5.6	19.2	14.4	9.1	6.7
	FR3	EVM344023	23	16	12	7.6	27.6	19.2	14.4	9.1	
		EVM344031	31	23	16	12	35.7	26.5	18.4	13.8	
	FR4	EVM344038	38	31	23	16	43.7	35.7	26.5	18.4	
		EVM344046	46	38	31	23	52.9	43.7	35.7	26.5	
	525 Vac to 600 Vac 50/60 Hz 3-phase	FR2	EVM3557D5	7.5	4.5	2.7	1.7	9	6	3.6	2.3
			EVM355010	10	7.5	4.5	2.7	12	9	5.4	3.2
EVM355013			13.5	10	7.5	4.5	16.2	12	9	5.4	
FR3		EVM355018	18	13.5	10	7.5	21.6	16.2	12	9	
FR4		EVM355022	22	18	13.5	10	26.4	21.6	16.2	12	
200 Vac to 240 Vac 50/60 Hz 1-phase voltage boosted	FR3	N/A	11	4.8	30	13.1					
		N/A	15	7.8	40	20.8					
		N/A	20	11	52	28.6					

Appendix E: Cable and Fuse Sizing Guidelines

The input current scaling describes what the input current will be if an undersized motor is applied to the drive. This allows for smaller cables and circuit protection where oversized drives are used. Three options are provided to allow flexibility in installations.

Input Voltage	Frame Size	Drive Model	Output rating			Input Rating					
			Max Rating	Option 1	Option 2	Option 3	Max Rating	Option 1	Option 2	Option 3	
			VT/IL Current Amps	VT/IL Current Amps	VT/IL Current Amps	VT/IL Current Amps	VT/IL Current Amps	VT/IL Current Amps	VT/IL Current Amps	VT/IL Current Amps	
100 Vac to 120 Vac 50/60 Hz 1- phase	FR1	EVM1122D5	2.5	1.6	1.3	1	10	6.4	5.2	4	
		EMV1124D8	4.8	2.5	1.6	1.3	20	11.3	7.2	5.9	
	FR2	EVM1126D9	6.9	4.8	2.5	1.6	26.4	20	10.4	6.7	
		EVM1127D8	7.8	6.9	4.8	2.5	30	26.4	18.4	9.6	
	200 Vac to 240 Vac 50/60 Hz 1- phase	FR1	EVM1222D5	2.5	1.6	1.3	1	6.5	4	3.3	2.5
			EVM1224D8	4.8	2.5	1.6	1.3	11	6.7	4.3	3.5
EVM1227D8			7.8	4.8	2.5	1.6	17	11	5.7	3.7	
FR2		EVM122011	11	7.8	4.8	2.5	23	18	11.1	5.8	
		EVM122017	17.5	11	7.8	4.8	35	23	16.3	10	
		EVM122025	25.3	17.5	11	7.8	49.6	38	23.9	16.9	
200 Vac to 240 Vac 50/60 Hz 3- phase	FR1	EVM3222D5	2.5	1.6	1.3	1	3.3	2.1	1.7	1.3	
		EVM3224D8	4.8	2.5	1.6	1.3	5.8	3.3	2.1	1.7	
		EVM3227D8	7.8	4.8	3	1.6	9.4	5.8	3	1.9	
		EVM322011	11	7.8	4.8	2.5	13.2	9.4	5.8	3	
	FR2	EVM322017	17.5	11	7.8	4.8	20.1	12.7	9	5.5	
		EVM322025	25.3	17.5	11	7.8	29.1	20.1	12.6	9	
	FR3	EVM322032	32.2	25.3	17.5	11	37	29.1	20.1	12.7	
		EVM322048	48.3	32.2	25.3	17.5	53.1	35.4	27.8	19.2	
	FR4	EVM322062	62.1	48.3	32.2	25.3	68.3	53.1	35.4	27.8	
380 Vac to 480 Vac 50/60 Hz 3- phase	FR1	EVM3442D2	2.2	1.5	1.1	0.9	2.6	1.8	1.3	1.1	
		EVM3444D3	4.3	2.2	1.5	1.1	5.2	2.6	1.8	1.3	
		EVM3445D6	5.6	4.3	2.2	1.5	3.7	5.2	2.7	1.8	
		EVM3447D6	7.6	5.6	4.3	2.2	9.1	6.7	5.1	2.6	
	FR2	EVM344012	12	7.6	5.6	4.3	14.4	9.1	6.7	5.1	
		EVM344016	16	12	7.6	5.6	19.2	14.4	9.1	6.7	
	FR3	EVM344023	23	16	12	7.6	27.6	19.2	14.4	9.1	
		EVM344031	31	23	16	12	35.7	26.5	18.4	13.8	
	FR4	EVM344038	38	31	23	16	43.7	35.7	26.5	18.4	
		EVM344046	46	38	31	23	52.9	43.7	35.7	26.5	
	525 Vac to 600 Vac 50/60 Hz 3- phase	FR2	EVM3557D5	7.5	4.5	2.7	1.7	9	6	3.6	2.3
			EVM355010	10	7.5	4.5	2.7	12	9	5.4	3.2
EVM355013			13.5	10	7.5	4.5	16.2	12	9	5.4	
FR3		EVM355018	18	13.5	10	7.5	21.6	16.2	12	9	
		EVM355022	22	18	13.5	10	26.4	21.6	16.2	12	
FR4		EVM355027	27	22	18	13.5	32.4	26.4	21.6	16.2	
200 Vac to 240 Vac 50/60 Hz 1- phase voltage boosted	FR3	N/A	11	4.8	30	13.1					
		N/A	15	7.8	40	20.8					
		N/A	20	11	52	28.6					

Copeland Commercial HVACR Variable Frequency Drive - EVM Series QUICK START GUIDE

This guide is a supplement to the application manual supplied with the drive. Improper wiring can cause bodily harm and damage the equipment. Follow good wiring practices and all applicable codes and standards.

MODEL NAMEPLATE

- Verify you received the correct model drive.
- Compare the drive nameplate VOLTS and AMPS rating with the motor or compressor nameplate.
- Check that the power source meets the input power requirements.
- Output power from the drive should match the motor requirement.



KEYPAD AND DISPLAY

- Use ▲ and ▼ arrows to navigate a menu list and change parameter values.
- Use ► arrow to enter parameter group mode and ◀ arrow to back up one step.

AC POWER WIRING

- Locate the power terminal strip.
- Check the AC voltage rating shown on the drive nameplate with the AC incoming voltage.
- Turn the power off and make connections.

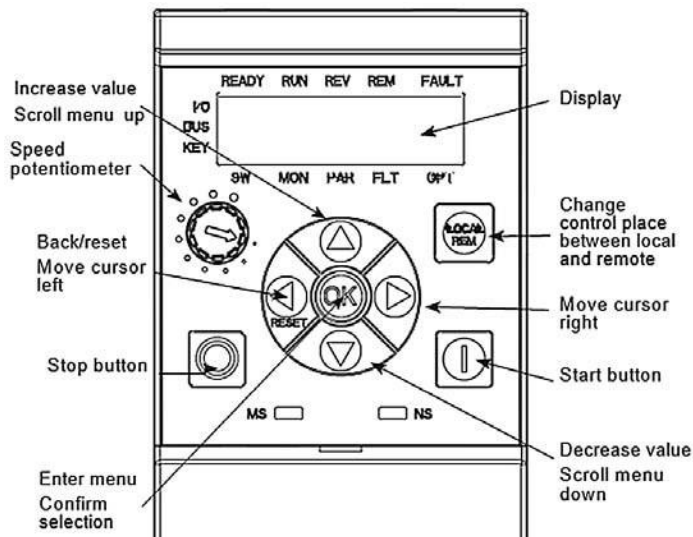

I/O WIRING

Refer to the *EVM Install Manual* for the complete I/O wiring guide.

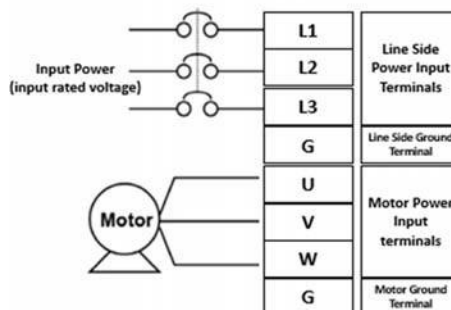

STARTUP WIZARD PARAMETERS

The following table lists the standard parameters. Refer to the application manual for parameter descriptions.

Item	Par. Name	Min Value	Max Value	Default
P13.1.7	Par. Password PIN	0	9999	0
P1.1	Minimum Freq	0.00 Hz	400 HZ	0.00 Hz
P1.2	Max Freq.	0.00 Hz	400.00 Hz	MaxFreqMFG
P1.6	Motor Nominal Current	DriveNomCurrCT* 1/10A	DriveNomCurrCT* 2A	DriveNomCurrCT
P1.7	Motor Nominal Speed	300 RPM	20,000 RPM	MotorNomSpeedMFG
P1.8	Motor Power Factor	0.30	1.00	0.85
P1.9	Motor Nominal Voltage	180V	690V	487V
P1.10	Motor Nominal Freq	8.00 Hz	400 Hz	MotorNomFreqMFG
P1.3	Accel. Time 1	0.10 s	3000.0 s	20.0 s
P1.4	Decel. Time 1	0.10 s	3000.0 s	20.0 s
P1.13	Remote Control Place	N.A	N.A	0
P1.14	Remote Ref.	N.A	N.A	0
P13.5.3	Keypad Password PIN	0	9999	0
P11.6.1	Blue Tooth Enable	N.A	N.A	N.A

FREQUENTLY ASKED QUESTIONS

Q: How do I reset the drive back to factory default settings?

A: Hold the OFF/STOP and BACK/RESET buttons for 5 seconds to return drive to factory default.

Q: How do I adjust the time it takes the motor to speed up or slow down?

A: To adjust the time for the motor to accelerate to set speed, find parameter P1.3 (accel time). To adjust the time for the motor to decelerate to 0, find parameter P1.4 (decel time).

Q: How do I prevent the drive from tripping on an overvoltage fault while my motor is ramping down?

A: Make the deceleration time longer for your ramp down, check input voltage, or activate overvoltage controller in parameter P5.1.12.

Q: Can I run my motor above the nominal motor speed?

A: The motor should be run within the speed range specified by the manufacturer. For Copeland™ compressors, please see AE-1456 for allowed speed ranges.

Appendix G: Variable Speed Key Parameters

Variable Speed Key Parameters

Parameter	Description	Recommended Value	Unit	Modbus I.D.
P13.1.2	Application Type *Apply 1st*	MultiPurpose (3)	Int.	142
P1.1	Min Frequency	N/A	Hz	101
P1.2	Max Frequency	N/A	Hz	102
P1.3	Accel Time 1	N/A	s	103
P1.4	Decel Time 1	N/A	s	104
P1.5	Motor Type Selection	IPM(1)	Int.	1820
P1.6	Motor Nom Current	See Note 1	A	486
P1.7	Motor Nom Speed	N/A	rpm	489
P1.8	Motor PF	0.98	%	490
P1.9	Motor Nom Voltage	N/A	V	487
P1.10	Motor Nom Frequency	See Note 2	Hz	488
P4.1.9	Stop Mode	Ramp (1) See Note 13	Int.	253
P4.5.5	Foldback Enable	See Note 3	Int.	1774
P5.1.1	Motor Control Mode	PM control2 (4)	Int.	287
P5.1.2	Current Limit	See Note 4	A	107
P5.1.17	Stator Resistor	See Note 5	ohm	771
P5.1.19	Initial Ld (Leak Inductance)	See Note 6	mH	773
P5.1.22	Motor Inertia	See Note 7	kgm ²	1881
P5.1.23	PM BEMF Voltage	See Note 8	V	1882
P5.1.24	PM d-axis stator inductance	N/A	mH	1884
P5.1.25	PM q-axis stator inductance	N/A	mH	1883
P5.2.2	Speed Control Kp1	See Note 9	%	1593
P5.2.3	Speed Control Ti1	See Note 9	ms	1594
P5.2.4	Speed Control FS1	See Note 9	Hz	1597
P5.2.5	Speed Control FS2	See Note 9	Hz	1598
P5.2.6	Speed Control Kp2	See Note 9	%	1599
P5.2.7	Speed Control Ti2	See Note 9	ms	1600
P5.2.15	PM Initial Selection	Align (0)	Int.	1890
P5.2.17	PM excited Current %	50	%	1892
P5.2.18	PM excited Current off frequency%	10	%	1893
P5.2.19	Observer Kp	150	%	2901
P5.2.20	Pulse Off Frequency	10	%	1768
P6.1.4	Motor Thermal Protection	No Action (0) See Note 10	Int.	310
P6.1.6	Stall Protection	Fault (2)	Int.	313
P6.1.7	Stall Current Limit	0.5	A	314
P6.1.8	Stall Time Limit	12	s	315
P6.1.9	Stall Frequency Limit	5	Hz.	316
P6.2.8	Cold Weather Mode	See Note 11	Int.	2126
P13.1.9	Startup Wizard	1 (Disable Wizard)	Int.	626

*Notes are listed on the next page

Appendix G: Variable Speed Key Parameters

NOTES	
Note 1	Max Operating Current, or no greater than the rated current of VFD
Note 2	Nominal freq (P1.7) and speed (P1.10) and must be equivalent (i.e. 350 Hz = 7000 RPM)
Note 3	Optional; allows the VFD to foldback in speed instead of alarm at high IGBT temps. Will eventually alarm if not resolved.
Note 4	Should not be higher than $P1.6 * 1.2$
Note 5	Set equal to $(L-L\Omega)/2$ OR use value provided by Application Engineering
Note 6	Should be set equal to P5.1.24
Note 7	No more than 3 decimal places e.g. (0.009)
Note 8	Use value provided by Application Engineering. Do not change unless directed.
Note 9	EVH Kp, FS and Ti nomenclatures are 1 less than EVM e.g. EVM = Kp1, EVH = Kp0, but have the same function.
Note 10	Motor Thermal Protection is not applicable for HVACR compressor applications.
Note 11	0 (Disabled) For Drive Ambient Temperature $>14^{\circ}\text{F}$ (-10°C) 1 (Enabled) For Drive Ambient Temperature $<14^{\circ}\text{F}$ (-10°C)

Appendix H: Communication Card Installation

Description	Part Number
ProfiBus DP Coms Card	962-0053-00
CANopen Com Card	962-0008-00

Installation Steps

Step 1 - Enclosed types

1. Remove the front cover (1) from the NEMA 1 kit.
2. Remove the terminal cover (2) from the NEMA 1 kit

Step 1 - Open types

Only remove the terminal cover (2) from the drive

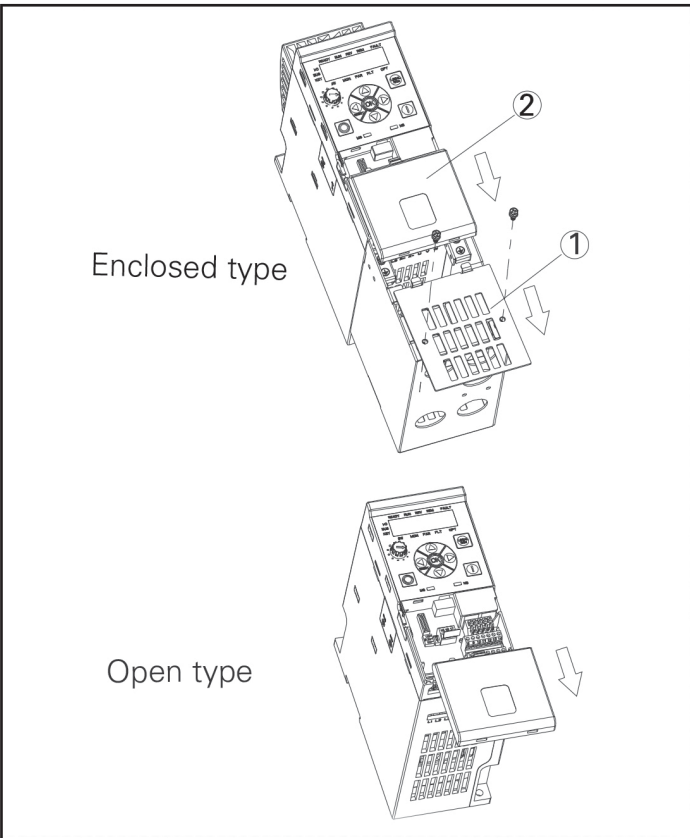

Step 2

Remove the option card port label and four snap covers from the drive.

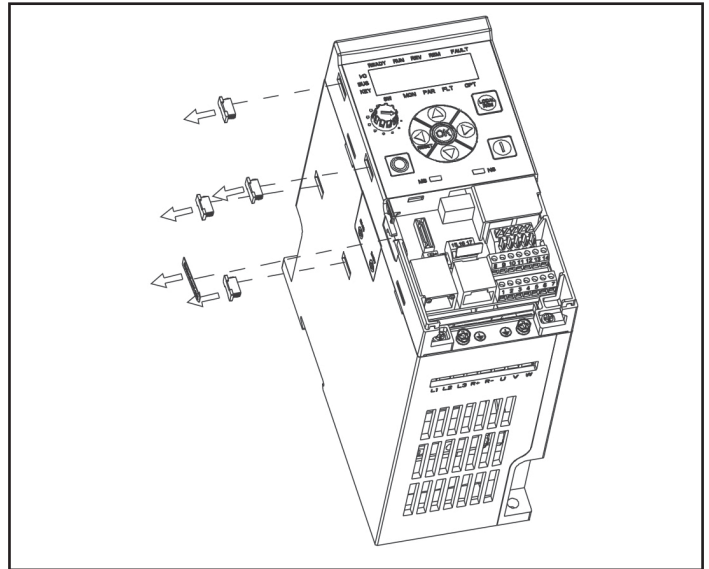

Step 3

Connect the cable to option card connector (3) and MCU board connector (4).

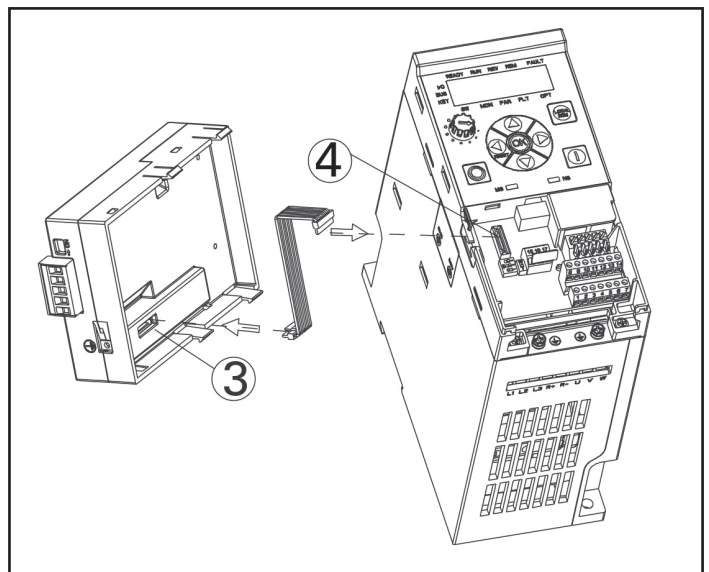

Appendix H: Communication Card Installation

Step 4 - Enclosed types

1. Remove Option Card Port sticker and clamp the cable with optional card port.
2. Mount the option card to the drive by inserting the four snaps into the slots on drive.

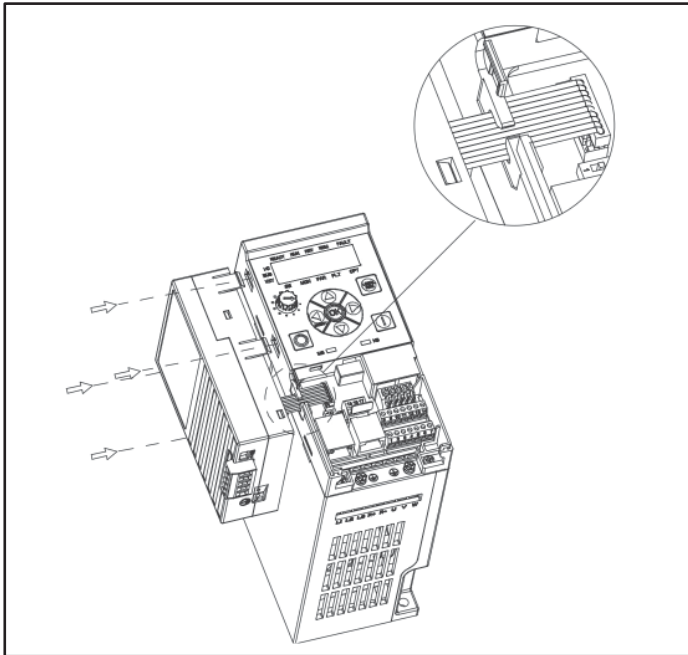

Step 5 - Enclosed types

1. Install the terminal cover ② to the drive.
2. Install the front cover ① to the NEMA 1 kit.

Step 5 - Open types

Only remove the terminal cover ② from the drive

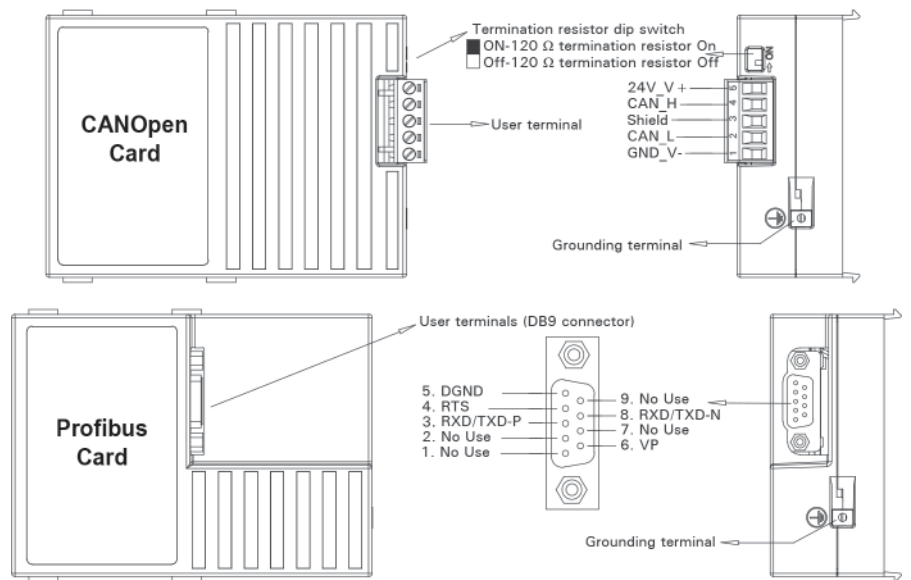
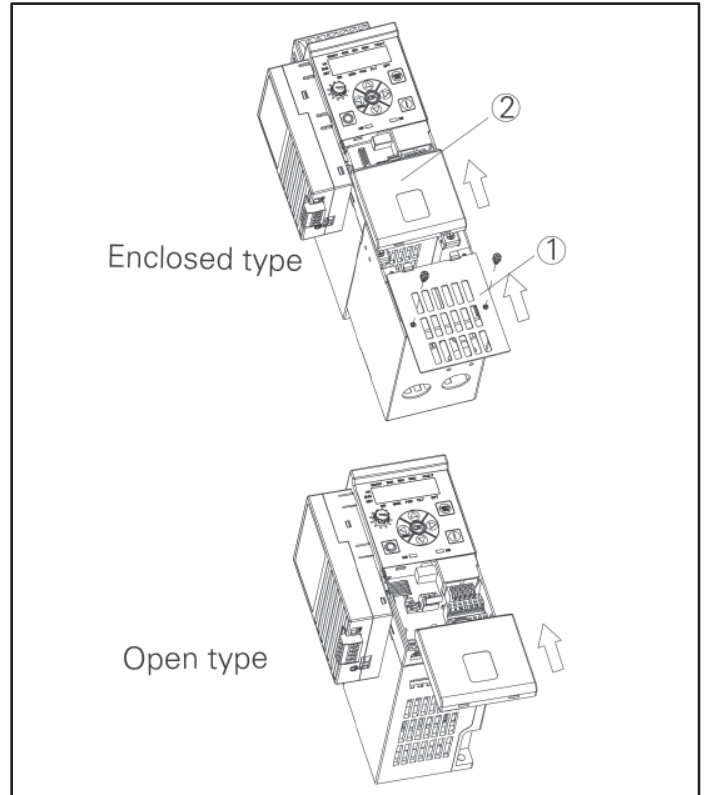

Figure 1 - Wiring Diagram

Appendix I: Troubleshooting and Fault Codes

Under this menu, you can find active faults, history faults, and fault codes.

Menu	Function	Note
Active Faults	When a fault/faults appear(s), the display with the name and fault time of the fault will be pop. Press DETAIL to see the fault data.	The fault remains active until it is cleared with the Reset button push for 2(s) or with a rest signal from the I/O terminal or fieldbus.
	The active faults submenu shows the list of faults. Select the fault and push DETAIL to see the fault data.	The memory of active faults can store the maximum of 10 faults in the order of appearance.

Menu	Function	Note
History Faults	10 latest faults are stored in the fault history. Select the fault and push DETAIL to see the fault data.	The history fault will be stored until it is cleared with the OK button (push for 5 s).
		The memory of active faults can store the maximum of 10 faults in order of appearance.

Fault Codes and Descriptions

Configurable 1 = The fault type of this fault is configurable; fault type can be configured as:

0 = No action; 1 = Warning; 2 = Fault; 3 = Fault, Coast.

Fault Code	Fault Name/Description	Fault Type	Default Configuration	Possible Cause	Remedy
FC1	Over current	Fault		AC drive has detected too high a current (>4*I _H) in the motor cable: <ul style="list-style-type: none"> Sudden heavy load increase Short circuit in motor cables Unsuitable motor 	<ul style="list-style-type: none"> Check loading Check motor Check cables and connections Make identification run Check ramp times
FC2	Over voltage	Fault		The DC-link voltage has exceeded the limits defined: <ul style="list-style-type: none"> Too short a deceleration time Brake chopper is disabled High overvoltage spikes in supply Start/stop sequence too fast 	<ul style="list-style-type: none"> Make deceleration time longer Use brake chopper or brake resistor (available as options) Activate overvoltage controller Check input voltage
FC3	Earth fault	Fault	Configurable	Current measurement has detected that the sum of motor phase current is not zero: <ul style="list-style-type: none"> Insulation failure in cables or motor 	<ul style="list-style-type: none"> Check motor cables and motor
FC9	Under voltage	Fault	Configurable	DC Link voltage is under the voltage limits defined: <ul style="list-style-type: none"> Most probable cause: Too low a supply voltage AC drive internal fault Defect input fuse External charge switch not closed Note: This fault is activated only if the drive is in the Run state.	In case of temporary supply voltage break reset the fault and restart the AC drive. Check the supply voltage. If it is adequate, an internal failure has occurred. Contact the distributor near you.
FC10	Input phase superv	No action	Configurable	Input line phase is missing.	<ul style="list-style-type: none"> Check supply voltage, fuses, and cable
FC11	Output phase superv	Fault	Configurable	Current measurement has detected that there is no current in one motor phase.	<ul style="list-style-type: none"> Check motor cable and motor
FC13	Drive under temp	Warning	Configurable	Too low temperature measured in power. Unit's heat sink or board. Heat sink temperature is under -10° C.	
FC14	Drive over temp	Fault		Too high temperature measured in power. Unit's heat sink or board. Heat sink temperature is over 90° C.	<ul style="list-style-type: none"> Check the correct amount and flow of cooling air Check the heat sink for dust Check ambient temperature Make sure that the switching frequency is not too high in relation to ambient temperature and motor load
FC15	Motor stalled	No action	Configurable	Motor is stalled.	<ul style="list-style-type: none"> Check motor and load

Appendix I: Troubleshooting and Fault Codes

Fault Code	Fault Name/Description	Fault Type	Default Configuration	Possible Cause	Remedy
FC16	Motor overload	No action	Configurable	Motor is too hot, based on either the drive's estimate or on temperature feedback.	Decrease motor load. If no motor overload exists, check the temperature model parameters.
FC17	Motor under load	No action	Configurable	Condition defined by parameter underload protection, underload from torque, underload F0 torque, valid longer than the time defined by underload time limit.	Check load.
FC18	IP address conflict	Warning	Configurable	IP setting issue	Check settings for IP address. Verify no duplicates are on the network.
FC19	Power board EEPROM fault	Fault		Power board EEPROM fault, memory lost in EEPROM.	Cycle power to drive. Try updating software. If issue continues, contact a distributor near you.
FC20	Control board EEPROM fault (MCU EEPROM fault)	Fault		EEPROM data error in EEPROM memory.	Cycle power to drive. Try updating software. If issue continues, contact a distributor near you.
FC21	S-flash fault	Warning		Serial flash error: serial flash memory failed.	Cycle power to drive. Try updating software. If issue continues, contact a distributor near you.
FC22	Speed deviation	Fault		Estimated speed is greater than 115% of maximum frequency or current loop is oscillating.	Check motor parameters and run identification. Adjust the Observer Kp.
FC23	STO circuit fault	Fault		STO switch is broken; STO circuit failure.	Check STO switch and STO circuit. If issue continues, contact a distributor near you.
FC25	MCU watchdog fault	Fault		Watchdog register overflows in MCU.	Cycle power to drive. Try updating software. If the issue continues, contact a distributor near you.
FC26	Start-up prevent	Fault		The time when interlock signal activates is over setting time.	Stop drive and resend start command.
FC37	Device change	Warning		Power board or option card change.	Alarm will reset.
FC38	Device added	Warning		Power board or option board added.	Device is ready for use. Old parameter settings will be used.
FC39	Device removed	Fault		Optional board removed from slot or power board removed from control board.	Device no longer available in drive.
FC40	Device unknown	Fault		Unknown device connected (power board/option board).	Check EEPROM connection. Check board connection on slot A/B. Power cycle to drive.
FC41	IGBT over temp	Fault		IGBT temperature is too high.	<ul style="list-style-type: none"> • Check output loading • Check motor size • Decrease switching frequency
FC50	AI < 4 mA (4 to 20 mA)	No action	Configurable	Loss in analog input signal, dropped below 4 mA.	Verify analog input current reference value on either A11 or A12, check cabling.
FC51	External fault	Fault	Configurable	Digital input is activated for external fault input.	Check digital input settings and verify input level, could be an external device causing fault.
FC52	Keypad comm. Fault	Fault	Configurable	The connection between the control keypad and frequency converter is broken, and the local reference is keypad reference, or the local control place is keypad, and the keypad communication fault protection is not "NO action".	Check keypad connection and possible keypad cable.
FC54	Option card fault	Fault	Configurable	Defective option card or option card slot.	Check right option card and option card slot connections. Check board status on keypad for exact cause of fault. Contact the distributor nearest to you.
FC57	Motor ID fault	Fault		The motor parameters identification running was not completed successfully.	Check motor size. Verify the input and output wiring are connected properly.
FC58	Current measure fault	Fault		Current measurement is out of range.	Restart the drive again. Should the fault re-occur, contact the distributor nearest to you.
FC66	Safety torque off	Fault	Configurable	STO triggered; STO input is open.	Reset STO trigger and verify wiring. Reset fault after input is enabled.
FC67	Current limit control	Warning		The output current has reached the current limit value.	Check the load. Set the acceleration time longer.

Appendix I: Troubleshooting and Fault Codes

Fault Code	Fault Name/Description	Fault Type	Default Configuration	Possible Cause	Remedy
FC68	Over voltage control	Warning		The DC link voltage has reached its voltage limit value.	Check input voltage. Set the acceleration/deceleration time longer.
FC70	System fault	Fault		MCU sending wrong parameters to DSP.	Restart the drive again. Should the fault re-occur, contact the distributor nearest to you.
FC80	Fieldbus fault	Fault	Configurable	BACnet IP fieldbus fault.	Check fieldbus communication wiring. Verify drive parameters are set correctly. Check BACnet master programming to verify proper addressing.
FC81	Fieldbus fault	Fault	Configurable	SA bus fieldbus fault.	Check fieldbus communication wiring on A/B terminal. Verify drive parameters are set correctly. Check SA bus master programming to verify proper addressing.
FC83	Fieldbus fault	Fault	Configurable	1: DCI_ubRTUBacNetFaultBehavior parameter's value is 0, loss of communication with Modbus RTU, and the fieldbus reference is the remote reference or the fieldbus control place is the remote control place, and the fault protection is not "NO action". 2: DCI_ubRTUBacNetFaultBehavior parameter's value is 1, loss of communication with Modbus TCP.	Check RS485 communication wiring. Verify drive parameters are set correctly. Check master programming to verify proper addressing.
FC84	Fieldbus fault	Fault	Configurable	1: DCI_ubTCPFaultBehavior parameter's value is 0, loss of communication with Modbus RTU, and the fieldbus reference is the remote reference or the fieldbus control place is the remote control place, and the fault protection is not "NO action". 2: DCI_ubTCPFaultBehavior parameter's value is 1, loss of communication with Modbus TCP.	Check ethernet communication wiring. Verify drive parameters are set correctly. Check master programming to verify proper addressing.
FC85	Fieldbus fault	Fault	Configurable	Loss of communication with BACnet, and the fieldbus reference is the remote reference OR the fieldbus control place is the remote control place, and the fault protection is not "NO action".	Check RS485 communication wiring. Verify drive parameters are set correctly. Check BACnet master programming to verify proper addressing.
86	Fieldbus fault	Fault	Configurable	Loss of communication ethernet IP, and the fieldbus reference is the remote reference OR the fieldbus control place is the remote control place, and the fault protection is not "NO action".	Check ethernet communication wiring. Verify drive parameters are set correctly. Check EIP master programming to verify proper addressing.
FC87	Fieldbus fault	Fault	Configurable	Loss of communication with Profibus/Canopen/Devicenet master on Slot A, and the fieldbus reference is the remote reference OR the fieldbus control place is the remote control place, and the fault protection is not "NO action".	Profibus/Canopen/Devicenet communication wiring. Verify drive parameters are set correctly. Check Profibus/Canopen/Devicenet master programming to verify proper addressing.
FC90	Drive under temp. (Cold weather drive under temp.)	Warning		<ul style="list-style-type: none"> Cold weather mode is not enabled, and unit temperature is less than -10°C. Cold weather mode is enabled and Under Temp Fault Override is not set, unit temperature is less than -30°C. Cold weather mode is enabled and Under Temp Fault Override is not set, unit temperature is -20 - -30°C. The temp <-20°C when cold weather starts timeout. 	If unit temp -20 - -10°C, start motor in cold weather mode. If unit temp <-20°C, warm up unit above -20°C for proper operation using cold weather mode. If it is still <-20°C when cold weather mode time out, try higher output voltage in cold weather mode.
FC92	External fault (External fault 2)	Fault	Configurable	Digital input is activated for external fault input.	Check digital input settings and verify input level, could be an external device causing fault.
FC93	External fault (External fault 3)	Fault	Configurable	Digital input is activated for external fault input.	Check digital input settings and verify input level, could be an external device causing fault.
FC97	Pipe fill loss (Prime loss)	No action	Configurable	<ul style="list-style-type: none"> In single drive control mode of MPFC, include FC, interlock enable, and all interlock signals lost. In single drive control mode of MPFC, not including FC, interlock enable, and all interlock 1 lost. In multi-drive network mode of MPFC, interlock enable, and interlock 1 lost. 	Check digital inputs for interlock.
FC98	PI feedback AI loss	No action	Configurable	The feedback function has a relationship with feedback ½ and the feedback ½ source has relationship with AI. The AI signal range is 1 (20-100%/2-10 V/4-20 mA). The AI value is out of range (AI mode: 0-20 mA, AI < 4 mA or AI > 20 mA, AI mode: 0-10 V, AI < 2 V or AI > 10 V) of PID1 feedback.	Check the AI of PI1 feedback, the AI value whether it is out of range or not, the AI range shall be 2-10 V (AI mode is 0-10 V) or 4-20 mA (AI mode is 0-20 mA).

Fault Code	Fault Name/Description	Fault Type	Default Configuration	Possible Cause	Remedy
FC100	Fieldbus fault	Fault	Configurable	Expansion card field bus fault	Check communications expansion card connections/reset and cycle power.
FC101	Option card fault	Fault	Configurable	Expansion card hardware fault	Remove expansion card. Check for damage. Replace if damaged, reset and cycle power.
FC102	External fault	Fault	Configurable	External fault - Expansion card	Remove expansion card. Check for damage. Replace if damaged, reset and cycle power.
FC103	Drive over temperature	Warning		Drive degree greater than DCI_wDriveOverTempThreshold value - 10 degrees and less than DCI_wDriveOverTempThreshold value; report drive over temperature warning.	Check the drive degree.
FC111	Profibus firmware incompatible	Warning		Profibus card firmware is not compatible with MCB firmware.	Check the Profibus card firmware revision.
FC113	CANOpen firmware incompatible	Warning		CANOpen card firmware is not compatible with MCB firmware.	Check the CANOpen firmware revision.
FC114	SWD firmware incompatible	Warning		SWD card firmware is not compatible with MCB firmware	Check the SWD card firmware revision.
FC115	Fieldbus fault	Fault	Configurable	Fieldbus EIP idle fault	Check ethernet IP master programming to verify proper addressing and ensure idle communication bit is not set.
FC117	Pump over cycle	Warning		During a period, the times which the drive sleeps and wakes up exceeds a user configurable value.	Check the reason drive is not stable. Check why drive sleeps and wakes up frequently.
FC118	Broken pipe	Warning	Configurable	PID feedback is less than broken pipe level and the drive output frequency is more than broke pipe frequency for delay time.	
FC125	Freq. limit supv. (Freq. limit)	No action		The output frequency exceeds the range of frequency supervision limit.	Check the output frequency and check the setting of frequency supervision limit.
FC126	Torque limit supv. (Torque limit)	No action		The motor torque exceeds the range of torque supervision limit.	Check the motor torque and check the setting of torque supervision limit.
FC127	Ref. limit supv. (Ref. limit)	No action		The frequency reference exceeds the range of freq. reference supervision limit.	Check the frequency reference and check the setting of frequency reference supervision limit.
FC128	Power limit supv. (Power limit)	No action		The motor power exceeds the range of power supervision limit.	Check the motor power and check the setting of power supervision limit.
FC129	Temp. limit supv. (Temp. limit)	No action		The unit temperature exceeds the range of temperature supervision limit.	Check the unit temperature and check the setting of temperature supervision limit.
FC130	AI limit supv. (AI limit)	No action		The AI value exceeds the range of AI supervision limit.	Check the AI value and check the setting of AI supervision limit.
FC131	Motor current supv. (Motor current limit)	No action		The motor current exceeds the range of current supervision limit.	Check the motor current and check the setting of current supervision limit.
FC132	PI superv.	No action		The PI1 feedback exceeds the range of PI1 supervision limit.	Check the PI1 feedback and check the setting of PI1 supervision limit.
FC133	Fieldbus fault (Fieldbus web UI fault)	Fault	Configurable	Fieldbus web UI fault	Check the web connection with RJ45 connector. Verify drive parameters are set correctly. Check the web UI tool to know if there is proper request going to drive or not.

Modbus RTU on-board communications

The drive product can be controlled via Modbus® RTU through the on-board RS-485 terminals.

EVM connection diagram.

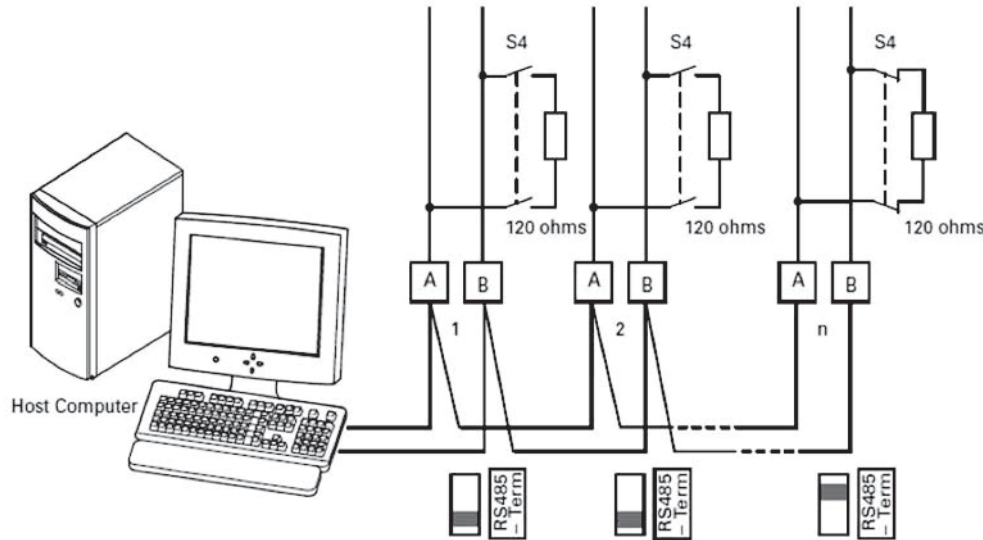

The figure shows a typical arrangement with a host computer (master) and any number maximum 31 slaves of frequency inverters. Each frequency inverter has a unique address in the network. This addressing is executed individually for each VFD via the communication parameters.

The electrical connection between master and the slaves connected in parallel are implemented via the serial interface A-B (A = positive, B = negative) with a shielded RS-485 twisted pair cable.

Communications

Item	Description
Modbus RTU	As described in "Modicon Modbus Protocol Reference Guide" found at: http://public.modicon.com/
Baud rate	9600,19200,38400,57600,115200
Addresses	1 to 247

Modbus RTU specifications

Communication board connections

Connections.

Item	Description
Interface	
Data transfer method	RS-485, half-duplex
Transfer cable	Twisted pair (1 pair and shield)
Electrical isolation	

Connections

The RS-485 communication port is connected via the A and B terminals on the drives control board.

Connection options

Connection options - main keypad.

Connection method	Port	Upgrade firmware	Connects to PC tool	Communication settings
RS-485	Modbus serial terminals			<div style="display: flex; justify-content: space-around;"> <div style="text-align: center;"> <p>EVM PRO</p> </div> <div style="text-align: center;"> <p>EVM</p> </div> </div> <p>RS-485 Comm Set: Settable in RS-485 communication parameter group. (Default modbus RTU). Note: If set to BACnet MSTP, PC Tool will not communicate.</p> <p>Slave address: Settable in RS-485 communication parameter group (Default 1).</p> <p>Baud rate: Settable in RS-485 communication parameter group (Default 19,200).</p> <p>Parity: Settable in RS-485 communication parameter group (Default even).</p> <p>Data bits: Not settable, 8 data bit.</p> <p>Stop bits: Not settable, 1 stop bit.</p>
	Keypad port			<div style="display: flex; justify-content: space-around;"> <div style="text-align: center;"> </div> <div style="text-align: center;"> <p>RJ45 port for Keypad/PC</p> </div> </div> <p>Slave address: Not settable, set to modbus ID 18.</p> <p>Baud rate: Not settable, set to 38,400 Kbaud.</p> <p>Parity: Not settable, set to even.</p> <p>Data bits: Not settable, 8 data bit.</p> <p>Stop bits: Not settable, 1 stop bit.</p>
Ethernet	Ethernet port	...		<div style="display: flex; justify-content: space-around;"> <div style="text-align: center;"> </div> <div style="text-align: center;"> <p>Ethernet port</p> </div> </div> <p>EVM PRO Only</p> <p>IP address mode: Settable in ethernet communication parameter group. (Default DHCP with AutoIP). Note: Most facilities require a static IP. Change the static IP address before changing. After changing this parameter, a reset or power cycle is required.</p> <p>Active IP address: Set depending on IP address assigned static or DHCP.</p> <p>Active subnet mask: Set depending on IP address assigned static or DHCP.</p> <p>Active default gateway: Set depending on IP address assigned static or DHCP.</p> <p>Static IP address: Settable in ethernet communication parameters group. (Default 192.168.1.245).</p> <p>Static subnet mask: Settable in ethernet communication parameters group. (Default 255.255.255.0).</p> <p>Static default gateway: Settable in ethernet communication parameters group. (Default 192.168.1.1).</p>

Appendix J: Modbus RTU Commissioning

Termination resistor and shielding.

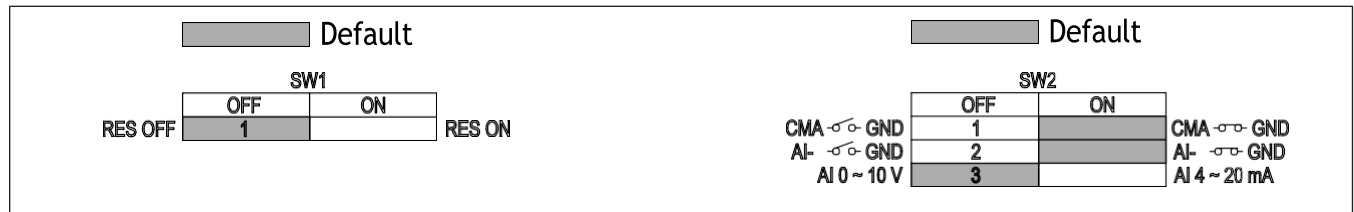

Commissioning

RS-485 communication parameters

To commission the RS-485 communication board, enter the Keypad menu as described below.

Change the Modbus RTU commissioning parameter values.

In this menu you will be able to scroll through the below settings to setup the communication protocol.

Modbus RTU.(cont).

P11.1 - Basic settings.

P11.1.1^①	<i>Serial communication</i>			ID 586
Minimum value:	N.A.	Maximum value:	N.A.	Default value: 0
Options:	0 = Modbus RTU 1 = BACnet MSTP (*EVM PRO) 2 = SWD (*EVM PRO) 3 = SA Bus (*EVM PRO).			
Description:	This parameter defines the communication protocol for RS-485.			

P11.2 - Modbus RTU.

P11.2.1^①	<i>Slave address</i>			ID 587
Minimum value:	1	Maximum value:	247	Default value: 1
Description:	This parameter defines the slave address for RS-485 communication.			
P11.2.2^①	<i>Baud rate</i>			ID 584
Minimum value:	N.A.	Maximum value:	N.A.	Default value: 1
Options:	0 = 9,600; 1 = 19,200; 2 = 38,400; 3 = 57,600; or 4 = 115,200			
Description:	This parameter defines communication speed for RS-485 communication.			
P11.2.3^①	<i>Parity type</i>			ID 585
Minimum value:	N.A.	Maximum value:	N.A.	Default value: 2
Options:	0 = None; 1 = Odd; or 2 = Even.			
Description:	This parameter defines parity type for RS-485 communication.			
P11.2.4	<i>Modbus RTU protocol status</i>			ID 588
Minimum value:	N.A.	Maximum value:	N.A.	Default value: N.A.
Options:	0 = Initial; 1 = Stopped; 2 = Operational; or 3 = Faulted.			

Modbus RTU (cont).

Description:	This parameter shows the protocol status for RS-485 communication.				
P11.2.5	Communication timeout modbus RTU			ID 593	
Minimum value:	0.00 ms	Maximum value:	60,000.00 ms	Default value:	10,000.00 ms
Description:	Selects the time to wait before a communication fault occurs over modbus RTU if a message is not received.				
P11.2.6	Modbus RTU fault response			ID 2516	
Minimum value:	N.A.	Maximum value:	N.A.	Default value:	0
Options:	0 - Only in fieldbus control mode. When fieldbus is the control place and fieldbus fault is active, the drive will fault on loss of communications; if not in fieldbus control, place will not fault. 1 - In all control modes. No matter the control place setting, if communication is lost, fieldbus fault response will occur.				
Description:	Defines the fieldbus fault condition for modbus RTU communication.				

Modbus communication standards

The Modbus protocol is an industrial communications and distributed control system to integrate PLCs, computers, terminals, and other monitoring, sensing and control devices. Modbus is a master-slave communications protocol. The master controls all serial activity by selectively polling one or more slave devices. The protocol provides for one master device and up to 247 slave devices on a common line. Each device is assigned an address to distinguish it from all other connected devices.

The Modbus protocol uses the master-slave technique, in which only one device (the master) can initiate a transaction. The other devices (the slaves) respond by supplying the requested data to the master, or by taking the action requested in the query. The master can address individual slaves or initiate a broadcast message to all slaves. Slaves return a message ("response") to queries that are addressed to them individually. Responses are not returned to broadcast queries from the master.

A transaction comprises a single query and single response frame or a single broadcast frame. The transaction frames are defined below.

Figure 4. The basic structure of a Modbus frame.

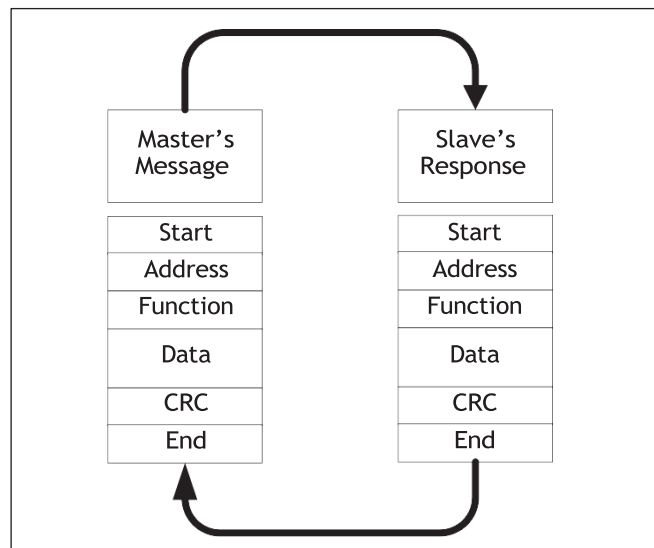

Valid slave device addresses are in the range of 0-247 decimal. The individual slave devices are assigned addresses in the range of 1-247. A master addresses a slave by placing the slave address in the address field of the message. When the slave sends its response, it places its own address in this address field of the response to let the master know which slave is responding.

The function code field of a message frame contains two characters (ASCII) or eight bits (RTU). Valid codes are in the range of 1-255 decimal. When a message is sent from a master to a slave device, the function code field tells the slave what kind of action to perform.

Examples are to read the ON/OFF states of a group of discrete coils or inputs; to read the data contents of a group of registers; to read the diagnostic status of the slave; to write to designated coils or registers; or to allow loading, recording or verifying the program within the slave.

Appendix J: Modbus RTU Commissioning

When the slave responds to the master, it uses the function code field to indicate either a normal (error-free) response or that some kind of error occurred (called an exception response). For a normal response, the slave simply echoes the original function code. For an exception response, the slave returns a code that is equivalent to the original function code with its most significant bit set to a logic state of 1.

The data field is constructed using sets of two hexadecimal digits, in the range of 00 to FF hexadecimal. These can be made from a pair of ASCII characters, or from one RTU character, according to the network's serial transmission mode.

The data field of messages sent from a master to slave devices contains additional information that the slave must use to take the action defined by the function code. This can include items like discrete and register addresses, the quantity of items to be handled, and the count of actual data bytes in the field.

If no error occurs, the data field of a response from a slave to a master contains the data requested. If an error occurs, the field contains an exception code that the master application can use to determine the next action to be taken.

Two kinds of checksum are used for standard Modbus networks. The error checking field contents depend upon the transmission method that is being used.

Supported functions

Functions.

Function code	Description
0x01	Read coils
0x02	Read discrete inputs
0x03	Read holding registers
0x04	Read input registers
0x05	Write single coil
0x06	Write single register
0x07	Read exception status
0x08	Read diagnostics (Only support 0x00 return query data)
0x0F	Write multiple coils
0x10	Write multiple registers
0x17	Read/write multiple registers
0x2B/0x0E	Read device identity

Note: Note: Broadcasting can be used with codes 0x05, 0x06, 0x0F, and 0x10.

Example of the request to read coils 2000-2003 from slave device 18.

Request to read coils.

Item	Code	Description
Slave address	0x12	
Function code	0x01	
Start address high	0x07	Starting address 0x07D0 hex (= 2000)
Start address low	0xD0	
Number of coils high	0x00	Number of coils 0x0003 hex (= 3)
Number of coils low	0x03	
CRC high	0x7E	
CRC low	0x25	

Example of the request to read discrete inputs 2000-2003 from slave device 18.

Request to read discrete inputs.

Item	Code	Description
Slave address	0x12	
Function code	0x02	
Start address high	0x07	Starting address 0x07D0 hex (= 2000)
Start address low	0xD0	
Number of discrete inputs high	0x00	Number of discrete inputs 0x0003 hex (= 3)
Number of discrete inputs low	0x03	
CRC high	0x3A	
CRC low	0x25	

Example of the request to read holding registers 2000-2003 from slave device 18.

Request to read holding registers.

Item	Code	Description
Slave address	0x12	
Function code	0x03	
Start address high	0x07	Starting address 0x07D0 hex (= 2000)
Start address low	0xD0	
Number of holding registers high	0x00	Number of holding registers 0x0003 hex (= 3)
Number of holding registers low	0x03	
CRC high	0x07	
CRC low	0xE5	

Appendix J: Modbus RTU Commissioning

Example of the request to read input registers 2000-2003 from slave device 18.

Request to read input registers.

Item	Code	Description
Slave address	0x12	
Function code	0x04	
Start address high	0x07	Starting address 0x07D0 hex (= 2000)
Start address low	0xD0	
Number of input registers high	0x00	Number of input registers 0x0003 hex (= 3)
Number of input registers low	0x03	
CRC high	0xB2	
CRC low	0x25	

Example of the request to read exception status from slave device 18.

Request to read exception status.

Item	Code	Description
Slave address	0x12	
Function code	0x07	
CRC high	4C	
CRC low	D2	

Example of read diagnostics from slave address 18.

Read diagnostics.

Item	Code	Description
Slave address	0x12	
Function code	0x08	
Sub function high	0x00	Sub function code 0x0000 (= 0)
Sub function low	0x00	Note: Only support sub function code 0x0000
Data high	0xA5	Data 0xA5A5 (= 42405)
Data low	0xA5	
CRC high	0x59	
CRC low	0x83	

Example of the request to write single coil 2000 from slave device 18, the output value is 65280.

Request to write single coil.

Item	Code	Description
Slave address	0x12	
Function code	0x05	
Output address high	0x07	Starting address 0x07D0 hex (= 2000)
Output address low	0xD0	
Output value high	0xFF	Output value 0xFF00 hex (= 65280)
Output value low	0x00	Note: Output value is 0x0000 or 0xFF00
CRC high	0x8E	
CRC low	0x14	

Example of the request to write single register 2000 from slave device 18, the output value is 5.

Request to write single register.

Item	Code	Description
Slave address	0x12	
Function code	0x06	
Output address high	0x07	Starting address 0x07D0 hex (= 2000)
Output address low	0xD0	
Output value high	0x00	Output value 0x0005 hex (= 5)
Output value low	0x05	
CRC high	0x4B	
CRC low	0xE7	

Example of write coils 19–28 from slave device 18.

Write coils 19-28.

Item	Code	Description
Slave address	0x12	
Function code	0x0F	
Starting address high	0x00	Starting address 0x0013 (= 19)
Starting address low	0x13	
Quantity of outputs high	0x00	Quantity of outputs 0x000A (= 10)
Quantity of outputs low	0x0A	
Byte count	0x02	
Outputs value high	0xCD	
Outputs value low	0x01	
CRC high	0xAB	
CRC low	0xFB	

Note: The binary outputs in the previous example correspond to the outputs in the following way.

Binary bits and corresponding outputs

Bit	1	1	0	0	1	1	0	1	0	0	0	0	0	1
Output	26	25	24	23	22	21	20	19	—	—	—	—	—	28

Appendix J: Modbus RTU Commissioning

Example of write holding registers 2000-2001 from slave device 18.

Request to write holding registers.

Item	Code	Description
Slave address	0x12	
Function code	0x10	
Starting address high	0x07	Starting address 0x07D0 (= 2000)
Starting address low	0xD0	
Quantity of outputs high	0x00	Quantity of outputs 0x0002 (= 2)
Quantity of outputs low	0x02	
Byte count	0x04	
Outputs value high	0x00	
Outputs value low	0x01	
Outputs value high	0x00	
Outputs value low	0x02	
CRC high	0x53	
CRC low	0x46	

Modbus registers

The variables and fault codes as well as the parameters can be read and written from Modbus. The parameter addresses are determined in the application. Every parameter and actual value have been given an ID number in the application. The ID numbering of the parameter, as well as the parameter ranges and steps, can be found in the application manual in question. The parameter value shall be given without decimals.

All values can be read with function codes 3 and 4 (all registers are 3X and 4X reference). Modbus registers are mapped to drive IDs as follows.

Index table.

ID	Modbus register	Group	R/W
1-98	40001-40098 (30001-30098)	Actual values	1/1
100	40099 (30099)	Fault code	1/1
101-1999	40101-41999 (30101-31999)	Parameters	1/1
2004-2011	42004-42011 (32004-32011)	Process data in	1/1
2104-2111	42104-42111 (32104-32111)	Process data out	1/1

Process data

The process data fields are used to control the drive (e.g., run, stop, reference, fault reset) and to quickly read actual values (e.g., output frequency, output current, fault code). The fields are structured as follows.

Process data slave → master (max. 22 bytes).

ID	Modbus register	Group	Range/type
2101	32101, 42101	FB status word	Binary coded
2102	32102, 42102	FB general status word	Binary coded
2103	32103, 42103	FB actual speed	0-100.00%
2104	32104, 42104	FB process data out 1	
2105	32105, 42105	FB process data out 2	
2106	32106, 42106	FB process data out 3	
2107	32107, 42107	FB process data out 4	
2108	32108, 42108	FB process data out 5	
2109	32109, 42109	FB process data out 6	
2110	32110, 42110	FB process data out 7	
2111	32111, 42111	FB process data out 8	

Process data master → slave (max. 22 bytes).

ID	Modbus register	Group	Range/type
2001	32001, 42001	FB control word	Binary coded
2002	32002, 42002	FB general control word	Binary coded
2003	32003, 42003	FB speed reference	0-100.00% Hz
2004	32004, 42004	FB process data in 1	Integer 16
2005	32005, 42005	FB process data in 2	Integer 16
2006	32006, 42006	FB process data in 3	Integer 16
2007	32007, 42007	FB process data in 4	Integer 16
2008	32008, 42008	FB process data in 5	Integer 16
2009	32009, 42009	FB process data in 6	Integer 16
2010	32010, 42010	FB process data in 7	Integer 16
2011	32011, 42011	FB process data in 8	Integer 16

The use of process data depends on the application. In a typical situation, the device is started and stopped with the control word (CW) written by the master and the rotating speed is set with reference (REF). With PD1-PD8, the device can be given other reference values (e.g., torque reference). With the status word (SW) read by the master, the status of the device can be seen. Actual value (ACT) and PD1-PD8 show the other actual values.

Appendix J: Modbus RTU Commissioning

Process data in

This register range is reserved for the control of the VFD. Process data in is located in range ID 2001-2099. The registers are updated every 10 ms. See table below.

Fieldbus (FB) basic input table

ID	Modbus register	Group	Range/type	ID	Modbus register	Group	Range/type
2001	32001, 42001	FB control word	Binary coded	2007	32007, 42007	FB process data in 4	Integer 16
2002	32002, 42002	FB general control word	Binary coded	2008	32008, 42008	FB process data in 5	Integer 16
2003	32003, 42003	FB speed reference	0-100.00%	2009	32009, 42009	FB process data in 6	Integer 16
2004	32004, 42004	FB process data in 1	Integer 16	2010	32010, 42010	FB process data in 7	Integer 16
2005	32005, 42005	FB process data in 2	Integer 16	2011	32011, 42011	FB process data in 8	Integer 16
2006	32006, 42006	FB process data in 3	Integer 16				

Note: For FB process data In, see section below on "Process data in".

Control word

The drive uses 16 bits as shown below. These bits are application specific.

Binary bits and corresponding outputs

15	14	13	12	11	10	9	8	7	6	5	4	3	2	1	0
①	①	①	①	①	①	FB Ref	FB Ctrl	Bypass	FB DI 4	FB DI 3	FB DI 2	FB DI 1	Fault Reset	Reverse	RUN

Note:

① The bit is not used.

FB control word.

Bit	Description Value = 0	Value = 1
0	Drive output off	Drive output on
1	Clockwise rotation	Counter clockwise
2	No reset	Fault reset
3	FB INDATA1 off	FB INDATA1 on
4	FB INDATA2 off	FB INDATA2 on
5	FB INDATA3 off	FB INDATA3 on
6	FB INDATA4 off	FB INDATA4 on
7	Bypass relay disable	Bypass relay enable
8	FB control off	FB control on
9	FB reference off	FB reference on
10-15	Not in use	Not in use

FB general control word

The EVM series drive does not use the FB general control word. The main control word is used to provide commands to the drive.

Speed reference

15	14	13	12	11	10	9	8	7	6	5	4	3	2	1	0
MSB	—	—	—	—	—	—	—	—	—	—	—	—	—	—	LSB

This is the reference 1 to the VFD. It is used normally as speed reference.

The scaling on this value is 0-100.00% of the maximum frequency. The 0 to 100.00% is represented by 0 to 10,000 value indicating 0 or 0% as minimum frequency and 10,000 or %100.00 as maximum frequency. This value has two decimal places in it.

Process data in 1 to 8

Process data in values 1 to 8 can be used in applications for various purposes. See "Process data in" section for setup.

Appendix J: Modbus RTU Commissioning

Process data out

This register range is normally used for fast monitoring of the VFD. Process data out is located in range ID 2101-2199. See the table below.

FB basic output table.

ID	Modbus register	Group	Range/type
2101	32101, 42101	FB status word	Binary coded
2102	32102, 42102	FB general status word	Binary coded
2103	32103, 42103	FB actual speed	%
2104	32104, 42104	FB process data out 1	
2105	32105, 42105	FB process data out 2	
2106	32106, 42106	FB process data out 3	
2107	32107, 42107	FB process data out 4	
2108	32108, 42108	FB process data out 5	
2109	32109, 42109	FB process data out 6	
2110	32110, 42110	FB process data out 7	
2111	32111, 42111	FB process data out 8	

FB status word

15	14	13	12	11	10	9	8	7	6	5	4	3	2	1	0
—	—	—	—	—	—	—	—	—	—	—	Direction	Fault	Direction	Running	Ready

Information about the status of the device and messages is indicated in the FB status word. The FB status word is composed of 16 bits that have the following meanings.

FB status word bit descriptions.

Bit	Description Value = 0	Value = 1
0	Not ready	Ready
1	Stop	Run
2	Clockwise	Counter clockwise
3	—	Faulted
4	—	Warning
5	Ref. frequency not reached	Ref. frequency reached
6	Bypass not activated	Bypass activated
7	Run disable	Run enable
8	Not in use	Not in use
9-15	Not in use	Not in use

FB general status word.

Bit	Description Value = 0	Value = 1
0	Not Ready	Ready
1	Stop	Run
2	Clockwise	Counter clockwise
3	No fault	Fault
4	No warning	Warning
5	Ref. frequency not reached	Ref. frequency reached
6	Ref. > 0 speed	Ref. = 0 speed
7	Motor flux off	Motor flux on ^①
8	Motor speed limit on	Motor speed limit off ^①
9	Encoder direction off	Encoder direction on ^①
10	Under voltage fast stop off	Under voltage fast stop on ^①
11	DC brake off	DC brake on
12	FB ref. not enable	FB ref. enabled
13	Motor start delay off	Motor start delay on
14	Remote not enable	Remote enable
15	FB WD pulse not enabled	FB WD pulse enable ^①

Note:

^① The bit is not used.

Speed reference

15	14	13	12	11	10	9	8	7	6	5	4	3	2	1	0
MSB	—	—	—	—	—	—	—	—	—	—	—	—	—	—	LSB

This is the actual speed of the motor. This value comes back in the form of %.

Appendix J: Modbus RTU Commissioning

Process data out 1 to 8

Process data out values 1 to 8 can be used in application for various purposes. See below tables for additional information.

Process data OUT (slave → master)

The fieldbus master can read the VFD actual values using process data variables. The applications use process data as follows.

These values are selectable via the fieldbus process data parameter group. These values would correspond to the Modbus ID value.

Process data OUT.

Id	Data	Value	Default value	Default para	Unit	Scale
2104	Process data OUT 1	-32768-32767	1	Output frequency	Hz	
2105	Process data OUT 2	-32768-32767	2	Motor speed	RPM	
2106	Process data OUT 3	-32768-32767	3	Motor current	A	
2107	Process data OUT 4	-32768-32767	4	Motor torque	%	
2108	Process data OUT 5	-32768-32767	5	Motor power	%	
2109	Process data OUT 6	-32768-32767	6	Motor voltage	V	
2110	Process data OUT 7	-32768-32767	7	DC link voltage	V	
2111	Process data OUT 8	-32768-32767	28	Latest fault code	—	

Process data IN (master → slave)

Control word, reference, and process data are used with "All-in-One" applications as follows.

Process data IN.

ID	Data	Value	Unit	Scale
2003	Reference	Speed Reference	Hz	0.01
2001	Control word	—	—	—
2004	Process data IN 1	①	%	0.01%
2005	Process data IN 2	①	%	0.01%
2006	Process data IN 3	①	%	0.01%
2007	Process data IN 4	①	%	0.01%
2008	Process data IN 5	①	%	0.01%
2009	Process data IN 6	①	%	0.01%
2010	Process data IN 7	①	%	0.01%
2011	Process data IN 8	①	%	0.01%

Note:

① Process data IN 1 through process data IN 8 change based off the selected application.

Startup test

Select Fieldbus (Bus/Comm) as the active control and reference place.

1. Set FB control word (Modbus Address 42001) value to 301hex.
2. The drive status is RUN.

3. Set FB speed reference (Modbus Address 42003) value to 5,000 (= 50.00%).
4. The actual value is 5,000 and the output frequency is 50.00%.
5. Set FB control word (Modbus Address 42001) value to 300 hex.
6. The drive status is STOP.

Parameter ID list

Parameter descriptions

EVM parameter ID list.(cont).

Menu item no	Modbus register	PROFIBUS PNU	PROFIBUS PNU subindex	EtherNet/IP class	EtherNet/IP instance	EtherNet/IP attribute	Parameter description	Data type	Length
M1.1	1	502	0	160	1	1	Output frequency	INTEGER	2
M1.2	24	1	0	160	1	2	Freq. reference	INTEGER	2
M1.3	2	503	0	4	70	3	Motor speed	INTEGER	2
M1.4	3	504	0	160	1	4	Motor current	INTEGER	2
M1.5	4	507	0	160	1	5	Motor torque	INTEGER	2
M1.6	5	513	1	160	1	6	Motor power	INTEGER	2
M1.7	6	501	0	160	1	7	Motor voltage	INTEGER	2
M1.8	7	501	1	160	1	8	DC-link voltage	INTEGER	2
M1.9	8	822	6	160	1	9	Unit temperature	INTEGER	2
M1.10	9	822	4	160	1	10	Motor temperature	INTEGER	2
M1.11	28	NA	NA	160	1	24	Latest fault code	BYTE	1
M1.12	1686	NA	NA	164	1	12	Instant motor power	DOUBLE	4
M2.1	10	560	0	160	1	11	Analog input 1	INTEGER	2
M2.2	1858	NA	NA	166	1	1	Keypad pot voltage	INTEGER	2
M2.3	25	570	0	4	75	3	Analog output	INTEGER	2
M2.4	12	760	0	160	1	13	DI1, DI2, DI3	BYTE	1
M2.5	13	760	1	160	1	14	DI4	BYTE	1
M2.6	1998	NA	NA	166	1	2	Virtual DI1, virtual DI2	BYTE	1
M2.7	1817	NA	NA	166	1	3	Virtual RO1, virtual RO2	BYTE	1
M2.8	557	762	0	160	1	15	RO1, RO2	BYTE	1
M3.1	2120	NA	NA	164	1	24	Energy savings	DOUBLE	4
M3.2	1818	NA	NA	166	1	4	CO2 savings	DOUBLE	4
M4.1	2209	NA	NA	166	1	5	Control board DIDO status	INTEGER	2
M4.2	29	NA	NA	160	1	23	Application status word	INTEGER	2
M4.3	2414	NA	NA	166	1	6	Standard status word	INTEGER	2
M4.4	2542	NA	NA	166	1	7	FB PI setpoint 1	DOUBLE	4
M4.5	2544	NA	NA	166	1	8	FB PI setpoint 2	DOUBLE	4
M4.6	2550	NA	NA	166	1	9	FB PI feedback	INTEGER	2
M5.1	16	2150	0	160	1	17	PI Set Point	DOUBLE	4
M5.2	18	2864	0	160	1	18	PI feedback	DOUBLE	4
M5.3	20	2167	0	160	1	19	PI error value	DOUBLE	4
M5.4	22	2124	0	160	1	20	PI output	INTEGER	2
M5.5	23	2133	0	160	1	21	PI status	BYTE	1
M6.1	2445	NA	NA	166	1	10	Output	DOUBLE	4
M6.2	2447	NA	NA	166	1	11	Reference	DOUBLE	4
M7.1.1	2218	NA	NA	165	1	1	Drive 1	BYTE	1
M7.1.2	2230	NA	NA	165	1	12	Drive 2	BYTE	1
M7.1.3	2242	NA	NA	165	1	23	Drive 3	BYTE	1
M7.1.4	2254	NA	NA	165	1	34	Drive 4	BYTE	1
M7.1.5	2266	NA	NA	165	1	45	Drive 5	BYTE	1
M7.2.1	2219	NA	NA	165	1	2	Drive 1	BYTE	1
M7.2.2	2231	NA	NA	165	1	13	Drive 2	BYTE	1
M7.2.3	2243	NA	NA	165	1	24	Drive 3	BYTE	1
M7.2.4	2255	NA	NA	165	1	35	Drive 4	BYTE	1
M7.2.5	2267	NA	NA	165	1	46	Drive 5	BYTE	1
M7.3.1	2220	NA	NA	165	1	3	Drive 1	BYTE	1

Appendix J: Modbus RTU Commissioning

Menu item no	Modbus register	PROFIBUS PNU	PROFIBUS PNU subindex	EtherNet/IP class	EtherNet/IP instance	EtherNet/IP attribute	Parameter description	Data type	Length
M7.3.2	2232	NA	NA	165	1	14	Drive 2	BYTE	1
M7.3.3	2244	NA	NA	165	1	25	Drive 3	BYTE	1
M7.3.4	2256	NA	NA	165	1	36	Drive 4	BYTE	1
M7.3.5	2268	NA	NA	165	1	47	Drive 5	BYTE	1
M8.1.1	2221	NA	NA	165	1	4	Drive 1	BYTE	1
M8.1.2	2233	NA	NA	165	1	15	Drive 2	BYTE	1
M8.1.3	2245	NA	NA	165	1	26	Drive 3	BYTE	1
M8.1.4	2257	NA	NA	165	1	37	Drive 4	BYTE	1
M8.1.5	2269	NA	NA	165	1	48	Drive 5	BYTE	1
M8.2.1	2222	NA	NA	165	1	5	Drive 1	INTEGER	2
M8.2.2	2234	NA	NA	165	1	16	Drive 2	INTEGER	2
M8.2.3	2246	NA	NA	165	1	27	Drive 3	INTEGER	2
M8.2.4	2258	NA	NA	165	1	38	Drive 4	INTEGER	2
M8.2.5	2270	NA	NA	165	1	49	Drive 5	INTEGER	2
M8.3.1	2223	NA	NA	165	1	6	Drive 1	INTEGER	2
M8.3.2	2235	NA	NA	165	1	17	Drive 2	INTEGER	2
M8.3.3	2247	NA	NA	165	1	28	Drive 3	INTEGER	2
M8.3.4	2259	NA	NA	165	1	39	Drive 4	INTEGER	2
M8.3.5	2271	NA	NA	165	1	50	Drive 5	INTEGER	2
M8.4.1	2224	NA	NA	165	1	7	Drive 1	INTEGER	2
M8.4.2	2236	NA	NA	165	1	18	Drive 2	INTEGER	2
M8.4.3	2248	NA	NA	165	1	29	Drive 3	INTEGER	2
M8.4.4	2260	NA	NA	165	1	40	Drive 4	INTEGER	2
M8.4.5	2272	NA	NA	165	1	51	Drive 5	INTEGER	2
M8.5.1	2225	NA	NA	165	1	8	Drive 1	INTEGER	2
M8.5.2	2237	NA	NA	165	1	19	Drive 2	INTEGER	2
M8.5.3	2249	NA	NA	165	1	30	Drive 3	INTEGER	2
M8.5.4	2261	NA	NA	165	1	41	Drive 4	INTEGER	2
M8.5.5	2273	NA	NA	165	1	52	Drive 5	INTEGER	2
M8.6.1	2226	NA	NA	165	1	9	Drive 1	INTEGER	2
M8.6.2	2238	NA	NA	165	1	20	Drive 2	INTEGER	2
M8.6.3	2250	NA	NA	165	1	31	Drive 3	INTEGER	2
M8.6.4	2262	NA	NA	165	1	42	Drive 4	INTEGER	2
M8.6.5	2274	NA	NA	165	1	53	Drive 5	INTEGER	2
M8.7.1	2227	NA	NA	165	1	10	Drive 1	INTEGER	2
M8.7.2	2239	NA	NA	165	1	21	Drive 2	INTEGER	2
M8.7.3	2251	NA	NA	165	1	32	Drive 3	INTEGER	2
M8.7.4	2263	NA	NA	165	1	43	Drive 4	INTEGER	2
M8.7.5	2275	NA	NA	165	1	54	Drive 5	INTEGER	2
M8.8.1	2228	NA	NA	165	1	11	Drive 1	DOUBLE	4
M8.8.2	2240	NA	NA	165	1	22	Drive 2	DOUBLE	4
M8.8.3	2252	NA	NA	165	1	33	Drive 3	DOUBLE	4
M8.8.4	2264	NA	NA	165	1	44	Drive 4	DOUBLE	4
M8.8.5	2276	NA	NA	165	1	55	Drive 5	DOUBLE	4
M9.1	30	329	0	160	1	25	Multi-monitoring	BYTE	3
P1.1	101	20	0	160	1	73	Min frequency	INTEGER	2
P1.2	102	20	1	160	1	74	Max frequency	INTEGER	2
P1.3	103	130	0	160	1	75	Accel. time 1	INTEGER	2
P1.4	104	134	0	160	1	76	Decel. time 1	INTEGER	2

Appendix J: Modbus RTU Commissioning

Menu item no	Modbus register	PROFIBUS PNU	PROFIBUS PNU subindex	EtherNet/IP class	EtherNet/IP instance	EtherNet/IP attribute	Parameter description	Data type	Length
P1.5	1820	NA	NA	40	1	3	Motor type selection	BYTE	1
P1.6	486	210	0	40	1	6	Motor nom. current	INTEGER	2
P1.7	489	217	0	40	1	15	Motor nom. speed	INTEGER	2
P1.8	490	215	0	161	1	38	Motor PF	INTEGER	2
P1.9	487	211	0	40	1	7	Motor nom. voltage	INTEGER	2
P1.10	488	216	0	161	1	40	Motor nom. frequency	INTEGER	2
P1.11	1695	NA	NA	164	1	14	Local control place	BYTE	1
P1.12	136	436	0	160	1	64	Local reference	BYTE	1
P1.13	135	408	0	160	1	63	Remote control place	BYTE	1
P1.14	137	437	0	160	1	65	Remote reference	BYTE	1
P2.1.1	144	35	1	160	1	30	AI ref scale min. value	INTEGER	2
P2.1.2	145	34	1	160	1	31	AI ref scale max. value	INTEGER	2
P2.1.3	143	425	0	160	1	80	IO terminal start stop logic	BYTE	1
P2.1.4	2297	NA	NA	166	1	12	Ext. fault 1 text	BYTE	1
P2.1.5	2298	NA	NA	166	1	13	Ext. fault 2 text	BYTE	1
P2.1.6	2299	NA	NA	166	1	14	Ext. fault 3 text	BYTE	1
P2.1.7	156	111	4	160	1	71	Motor pot ramp time	INTEGER	2
P2.1.8	169	426	0	160	1	72	Motor pot ref. reset	BYTE	1
P2.2.1	1801	NA	NA	166	1	15	DI1 function	BYTE	1
P2.2.2	1802	NA	NA	166	1	16	DI1 invert	BYTE	1
P2.2.3	1803	NA	NA	166	1	17	DI2 function	BYTE	1
P2.2.4	1804	NA	NA	166	1	18	DI2 invert	BYTE	1
P2.2.5	1805	NA	NA	166	1	19	DI3 function	BYTE	1
P2.2.6	1806	NA	NA	166	1	20	DI3 invert	BYTE	1
P2.2.7	1807	NA	NA	166	1	21	DI4 function	BYTE	1
P2.2.8	1808	NA	NA	166	1	22	DI4 invert	BYTE	1
P2.2.9	1809	NA	NA	166	1	23	Virtual RO1 input	BYTE	1
P2.2.10	1810	NA	NA	166	1	24	Virtual RO1 invert	BYTE	1
P2.2.11	1811	NA	NA	166	1	25	Virtual RO2 input	BYTE	1
P2.2.12	1812	NA	NA	166	1	26	virtual RO2 invert	BYTE	1
P2.3.1	105	5	1	161	1	5	Preset speed 1	INTEGER	2
P2.3.2	106	5	2	161	1	6	Preset speed 2	INTEGER	2
P2.3.3	118	5	3	161	1	7	Preset speed 3	INTEGER	2
P2.3.4	119	5	4	161	1	8	Preset speed 4	INTEGER	2
P2.3.5	120	5	5	161	1	9	Preset speed 5	INTEGER	2
P2.3.6	121	5	6	161	1	10	Preset speed 6	INTEGER	2
P2.3.7	122	5	7	161	1	11	Preset speed 7	INTEGER	2
P2.3.8	117	1	9	160	1	70	Jog reference	INTEGER	2
P2.4.1	222	263	0	160	1	32	AI mode	BYTE	1
P2.4.2	175	260	0	160	1	33	AI signal range	BYTE	1
P2.4.3	176	264	0	160	1	34	AI custom min.	INTEGER	2
P2.4.4	177	265	0	160	1	35	AI custom max.	INTEGER	2
P2.4.5	174	266	0	160	1	36	AI filter time	INTEGER	2
P2.4.6	181	267	0	160	1	37	AI signal invert	BOOLEAN	1
P2.4.7	178	1711	0	160	1	38	AI joystick hyst.	INTEGER	2
P2.4.8	179	1720	0	160	1	39	AI sleep limit	INTEGER	2
P2.4.9	180	1721	0	160	1	40	AI sleep delay	INTEGER	2
P2.4.10	133	1712	0	160	1	41	AI joystick offset	INTEGER	2
P2.5.1	1814	NA	NA	166	1	27	Pot custom min.	INTEGER	2

Appendix J: Modbus RTU Commissioning

Menu item no	Modbus register	PROFIBUS PNU	PROFIBUS PNU subindex	EtherNet/IP class	EtherNet/IP instance	EtherNet/IP attribute	Parameter description	Data type	Length
P2.5.2	1815	NA	NA	166	1	28	Pot custom max.	INTEGER	2
P2.5.3	1816	NA	NA	166	1	29	Pot filter time	INTEGER	2
P3.1.1	152	451	0	160	1	47	RO1 function	BYTE	1
P3.1.2	2112	NA	NA	164	1	20	RO1 on delay	INTEGER	2
P3.1.3	2113	NA	NA	164	1	21	RO1 off delay	INTEGER	2
P3.1.4	153	451	1	160	1	48	RO2 function	BYTE	1
P3.1.5	2114	NA	NA	164	1	22	RO2 on delay	INTEGER	2
P3.1.6	2115	NA	NA	164	1	23	RO2 off delay	INTEGER	2
P3.1.7	2118	NA	NA	166	1	30	RO2 reverse	BYTE	1
P3.1.8	2463	NA	NA	166	1	31	Virtual RO1 function	BYTE	1
P3.1.9	2464	NA	NA	166	1	32	Virtual RO2 function	BYTE	1
P3.2.1	154	1201	0	160	1	49	Freq limit supv.	BYTE	1
P3.2.2	1821	NA	NA	166	1	33	Freq limit display	BYTE	1
P3.2.3	155	1101	0	160	1	50	Freq limit supv. val	INTEGER	2
P3.2.4	2200	NA	NA	166	1	34	Freq limit supv. hyst.	INTEGER	2
P3.2.5	159	1202	0	160	1	51	Torque limit supv.	BYTE	1
P3.2.6	1822	NA	NA	166	1	35	Torque limit display	BYTE	1
P3.2.7	160	1102	0	160	1	52	Torque limit supv. val.	INTEGER	2
P3.2.8	2202	NA	NA	166	1	36	Torque limit supv. hyst.	INTEGER	2
P3.2.9	161	1200	0	160	1	53	Ref limit supv.	BYTE	1
P3.2.10	1823	NA	NA	166	1	37	Ref limit display	BYTE	1
P3.2.11	162	1100	0	160	1	54	Ref limit supv. val.	INTEGER	2
P3.2.12	2203	NA	NA	166	1	38	Ref limit supv. hyst.	INTEGER	2
P3.2.13	165	1222	1	160	1	55	Temp limit supv.	BYTE	1
P3.2.14	1824	NA	NA	166	1	39	Temp limit display	BYTE	1
P3.2.15	166	822	0	160	1	56	Temp limit supv. val.	INTEGER	2
P3.2.16	2204	NA	NA	166	1	40	Temp limit supv. hyst.	INTEGER	2
P3.2.17	167	1203	0	160	1	57	Power limit supv.	BYTE	1
P3.2.18	1825	NA	NA	166	1	41	Power limit display	BYTE	1
P3.2.19	168	1103	0	160	1	58	Power limit supv. val.	INTEGER	2
P3.2.20	2205	NA	NA	166	1	42	Power limit supv. hyst.	INTEGER	2
P3.2.21	170	1504	0	160	1	59	AI supv. select	BYTE	1
P3.2.22	171	1204	0	160	1	60	AI limit supv.	BYTE	1
P3.2.23	1826	NA	NA	166	1	43	AI limit display	BYTE	1
P3.2.24	172	1404	0	160	1	61	AI limit supv. val.	INTEGER	2
P3.2.25	2198	NA	NA	166	1	44	AI supv. hyst.	INTEGER	2
P3.2.26	2189	NA	NA	166	1	45	Motor current supv.	BYTE	1
P3.2.27	1827	NA	NA	166	1	46	Motor current limit display	BYTE	1
P3.2.28	2190	NA	NA	166	1	47	Motor current supv. value	INTEGER	2
P3.2.29	2196	NA	NA	166	1	48	Motor current supv. hyst.	BYTE	1
P3.2.30	1346	2860	0	161	1	1	PI superv. enable	BOOLEAN	1
P3.2.31	1828	NA	NA	166	1	49	PI superv. display	BYTE	1
P3.2.32	1347	2861	0	161	1	2	PI superv. upper limit	DOUBLE	4
P3.2.33	1349	2862	0	161	1	3	PI superv. lower limit	DOUBLE	4
P3.2.34	1351	2863	0	161	1	4	PI superv. delay	INTEGER	2
P3.3.1	227	276	0	160	1	42	AO mode	BYTE	1
P3.3.2	146	460	0	160	1	43	AO function	BYTE	1
P3.3.3	147	277	0	160	1	45	AO filter time	INTEGER	2
P3.3.4	1863	NA	NA	166	1	50	AO custom min.	DOUBLE	4

Appendix J: Modbus RTU Commissioning

Menu item no	Modbus register	PROFIBUS PNU	PROFIBUS PNU subindex	EtherNet/IP class	EtherNet/IP instance	EtherNet/IP attribute	Parameter description	Data type	Length
P3.3.5	1865	NA	NA	166	1	51	AO custom max.	DOUBLE	4
P3.3.6	1867	NA	NA	166	1	52	AO value min.	INTEGER	2
P3.3.7	1868	NA	NA	166	1	53	AO value max.	INTEGER	2
P4.1.1	141	1	8	160	1	66	Keypad reference	INTEGER	2
P4.1.2	116	621	1	160	1	67	Keypad/drive ref. pot direction	BOOLEAN	1
P4.1.3	114	622	1	160	1	68	Keypad stop	BOOLEAN	1
P4.1.4	1679	622	3	164	1	9	Reverse enable	BYTE	1
P4.1.5	2515	NA	NA	166	1	54	Change phase sequence motor	BYTE	1
P4.1.6	1685	NA	NA	164	1	11	Power up local remote select	BYTE	1
P4.1.7	2462	NA	NA	166	1	55	Bumpless enable	BYTE	1
P4.1.8	252	620	0	160	1	78	Start mode	BYTE	1
P4.1.9	253	620	1	160	1	79	Stop mode	BYTE	1
P4.1.10	247	117	0	160	1	77	Ramp 1 shape	INTEGER	2
P4.1.11	248	117	1	160	1	83	Ramp 2 shape	INTEGER	2
P4.1.12	249	130	1	160	1	81	Accel. time 2	INTEGER	2
P4.1.13	250	134	1	160	1	82	Decel. time 2	INTEGER	2
P4.1.14	2444	NA	NA	166	1	56	2 nd stage ramp frequency	INTEGER	2
P4.1.15	2483	NA	NA	166	1	57	Fault reset start	BYTE	1
P4.2.1	1829	NA	NA	166	1	58	Brake chopper enable	BYTE	1
P4.2.2	254	2227	0	161	1	24	DC-brake current	INTEGER	2
P4.2.3	263	2222	0	161	1	25	Start DC-brake time	INTEGER	2
P4.2.4	262	2223	0	161	1	26	Stop DC-brake frequency	INTEGER	2
P4.2.5	255	2222	1	161	1	27	Stop DC-brake time	INTEGER	2
P4.2.6	266	2214	0	161	1	28	Flux brake	BOOLEAN	1
P4.2.7	265	2217	0	161	1	29	Flux brake current	INTEGER	2
P4.3.1	264	43	0	160	1	90	Skip range ramp factor	INTEGER	2
P4.3.2	256	41	0	160	1	84	Skip F1 low limit	INTEGER	2
P4.3.3	257	42	0	160	1	85	Skip F1 high limit	INTEGER	2
P4.3.4	258	41	1	160	1	86	Skip F2 low limit	INTEGER	2
P4.3.5	259	42	1	160	1	87	Skip F2 high limit	INTEGER	2
P4.3.6	260	41	2	160	1	88	Skip F3 low limit	INTEGER	2
P4.3.7	261	42	2	160	1	89	Skip F3 high limit	INTEGER	2
P4.4.1	2122	NA	NA	164	1	25	Currency	BYTE	1
P4.4.2	2123	NA	NA	164	1	26	Energy cost	INTEGER	2
P4.4.3	2124	NA	NA	164	1	27	Data type	BYTE	1
P4.4.4	2125	NA	NA	164	1	28	Energy savings reset	BYTE	1
P5.1.1	287	255	0	161	1	19	Motor control mode	BYTE	1
P5.1.2	107	281	0	42	1	10	Current limit	INTEGER	2
P5.1.3	109	60	0	161	1	20	V/Hz optimization	BOOLEAN	1
P5.1.4	108	61	0	161	1	12	V/Hz ratio	BYTE	1
P5.1.5	289	23	0	161	1	13	Field weakening point	INTEGER	2
P5.1.6	290	24	0	161	1	14	Voltage at FWP	INTEGER	2
P5.1.7	291	23	1	161	1	15	V/Hz mid frequency	INTEGER	2
P5.1.8	292	24	1	161	1	16	V/Hz mid voltage	INTEGER	2
P5.1.9	293	27	0	161	1	17	Zero frequency voltage	INTEGER	2
P5.1.10	2522	390	0	161	1	18	Switching frequency	INTEGER	2
P5.1.11	1665	341	0	164	1	2	Sine filter enabled	BYTE	1
P5.1.12	294	626	3	161	1	21	Overvoltage controller	BYTE	1
P5.1.13	1874	NA	NA	166	1	59	Overvoltage controller reference	INTEGER	2
P5.1.14	298	2901	0	161	1	22	Load drooping	INTEGER	2

Appendix J: Modbus RTU Commissioning

Menu item no	Modbus register	PROFIBUS PNU	PROFIBUS PNU subindex	EtherNet/IP class	EtherNet/IP instance	EtherNet/IP attribute	Parameter description	Data type	Length
P5.1.15	1630	2902	0	163	1	95	Droop control filter time constant	INTEGER	2
P5.1.16	299	340	0	161	1	23	Identification	BYTE	1
P5.1.17	771	218	0	162	1	82	Stator resistor	INTEGER	2
P5.1.18	772	221	0	162	1	83	Rotor resistor	INTEGER	2
P5.1.19	773	224	0	162	1	84	Leak inductance	INTEGER	2
P5.1.20	774	225	0	162	1	85	Mutual inductance	INTEGER	2
P5.1.21	775	223	0	162	1	86	Excitation current	INTEGER	2
P5.1.22	1881	NA	NA	166	1	60	Motor inertia	INTEGER	2
P5.1.23	1882	NA	NA	166	1	61	PM BEMF voltage	INTEGER	2
P5.1.24	1884	NA	NA	166	1	62	PM d-axis stator inductance	INTEGER	2
P5.1.25	1883	NA	NA	166	1	63	PM q-axis stator inductance	INTEGER	2
P5.1.26	1664	NA	NA	164	1	1	Slip compensation coefficient	INTEGER	2
P5.1.27	1656	NA	NA	166	1	64	VF stable Kd	INTEGER	2
P5.1.28	1657	NA	NA	166	1	65	VF stable Kq	INTEGER	2
P5.1.29	2835	NA	NA	166	1	66	Over-modulation enable	BYTE	1
P5.2.1	1591	2406	1	163	1	91	Speed error filter time constant	INTEGER	2
P5.2.2	1593	NA	NA	166	1	67	Speed control Kp1	INTEGER	2
P5.2.3	1594	NA	NA	166	1	68	Speed control Ti1	INTEGER	2
P5.2.4	1597	NA	NA	166	1	69	Speed control FS1	INTEGER	2
P5.2.5	1598	NA	NA	166	1	70	Speed control FS2	INTEGER	2
P5.2.6	1599	NA	NA	166	1	71	Speed control Kp2	INTEGER	2
P5.2.7	1600	NA	NA	166	1	72	Speed control Ti2	INTEGER	2
P5.2.8	1836	NA	NA	166	1	73	Motoring torque limit FWD	INTEGER	2
P5.2.9	1837	NA	NA	166	1	74	Generator torque limit FWD	INTEGER	2
P5.2.10	1838	NA	NA	166	1	75	Motoring torque Limit REV	INTEGER	2
P5.2.11	1839	NA	NA	166	1	76	Generator torque limit REV	INTEGER	2
P5.2.12	1607	282	0	163	1	92	Motoring power limit	INTEGER	2
P5.2.13	1608	282	1	163	1	93	Generator power limit	INTEGER	2
P5.2.14	1620	254	0	163	1	94	Flux reference	INTEGER	2
P5.2.15	1890	NA	NA	166	1	77	PM initial selection	BYTE	1
P5.2.16	1891	NA	NA	166	1	78	PM initial time	INTEGER	2
P5.2.17	1892	NA	NA	166	1	79	PM excited current	INTEGER	2
P5.2.18	1893	NA	NA	166	1	80	PM excited current off frequency	INTEGER	2
P5.2.19	2901	NA	NA	166	1	81	Observer Kp	INTEGER	2
P6.1.1	308	840	9040	160	1	108	Output phase fault	BYTE	1
P6.1.2	309	840	9008	160	1	110	Ground fault	BYTE	1
P6.1.3	2158	NA	NA	164	1	42	Ground fault limit	BYTE	1
P6.1.4	310	840	17168	160	1	101	Motor thermal protection	BYTE	1
P6.1.5	311	1012	0	160	1	102	Motor thermal F0 current	INTEGER	2
P6.1.6	313	840	28963	160	1	93	Stall protection	BYTE	1
P6.1.7	314	1010	0	160	1	94	Stall current limit	INTEGER	2
P6.1.8	315	1010	1	160	1	95	Stall time limit	INTEGER	2
P6.1.9	316	1010	2	160	1	96	Stall frequency limit	INTEGER	2
P6.1.10	317	840	28979	160	1	97	Underload protection	BYTE	1
P6.1.11	318	1013	0	160	1	98	Underload fnom. torque	INTEGER	2
P6.1.12	319	1013	1	160	1	99	Underload F0 torque	INTEGER	2
P6.1.13	320	1011	1	160	1	100	Underload time limit	INTEGER	2
P6.1.14	2159	NA	NA	164	1	43	Preheat mode	BYTE	1
P6.1.15	2160	NA	NA	164	1	44	Preheat control source	BYTE	1

Appendix J: Modbus RTU Commissioning

Menu item no	Modbus register	PROFIBUS PNU	PROFIBUS PNU subindex	EtherNet/IP class	EtherNet/IP instance	EtherNet/IP attribute	Parameter description	Data type	Length
P6.1.16	2161	NA	NA	164	1	45	Preheat enter temp.	INTEGER	2
P6.1.17	2162	NA	NA	164	1	46	Preheat quit temp.	INTEGER	2
P6.2.1	750	861	0	162	1	59	Line start lockout	BYTE	1
P6.2.2	332	840	12592	160	1	107	Input phase fault	BYTE	1
P6.2.3	306	840	29520	160	1	91	4 mA input fault	BYTE	1
P6.2.4	331	1	7	160	1	92	4 mA fault frequency	INTEGER	2
P6.2.5	307	840	36864	160	1	106	External fault	BYTE	1
P6.2.6	330	840	12576	160	1	109	U-volt fault response	BYTE	1
P6.2.7	1564	840	16912	163	1	89	Unit under temp. prot.	BYTE	1
P6.2.8	2126	NA	NA	164	1	29	Cold weather mode	BYTE	1
P6.2.9	2127	NA	NA	164	1	30	Cold weather volt level	BYTE	1
P6.2.10	2128	NA	NA	164	1	31	Cold weather time out	BYTE	1
P6.2.11	2427	NA	NA	166	1	82	STO fault response	BYTE	1
P6.2.12	2401	NA	NA	166	1	83	PI feedback AI loss response	BYTE	1
P6.2.13	2402	NA	NA	166	1	84	PI feedback AI loss prefreq.	INTEGER	2
P6.2.14	2403	NA	NA	166	1	85	PI feedback AI loss pipe fill loss level	INTEGER	2
P6.2.15	2404	NA	NA	166	1	86	PI feedback AI loss prefreq. time-out	INTEGER	2
P6.2.16	1840	NA	NA	166	1	87	Overvoltage controller response	BYTE	1
P6.2.17	1841	NA	NA	166	1	88	Overcurrent controller response	BYTE	1
P6.2.18	2129	NA	NA	164	1	32	Cold weather password	INTEGER	2
P6.2.19	2130	NA	NA	164	1	33	Under temp. fault override	BYTE	1
P6.3.1	334	840	29953	160	1	104	Fieldbus fault response	BYTE	1
P6.3.2	335	840	35088	160	1	105	OPTcard fault response	BYTE	1
P6.3.3	1678	840	30070	163	1	88	IP address confliction resp.	BYTE	1
P6.3.4	2157	NA	NA	164	1	41	Keypad comm. fault response	BYTE	1
P6.4.1	321	846	0	160	1	111	AR wait time	INTEGER	2
P6.4.2	322	846	1	160	1	112	AR trail time	INTEGER	2
P6.4.3	323	847	0	160	1	113	AR start function	BYTE	1
P6.4.4	324	845	12832	160	1	114	Under-voltage attempts	BYTE	1
P6.4.5	325	845	12816	160	1	115	Over-voltage attempts	BYTE	1
P6.4.6	326	845	8736	160	1	116	Over-current attempts	BYTE	1
P6.4.7	327	845	29520	160	1	117	4 mA fault attempts	BYTE	1
P6.4.8	329	845	28978	160	1	118	Motor temp. fault attempts	BYTE	1
P6.4.9	328	845	36864	160	1	119	External fault attempts	BYTE	1
P6.4.10	336	845	28979	160	1	120	Underload attempts	BYTE	1
P6.4.11	2405	NA	NA	166	1	89	PI feedback AI loss attempts	BYTE	1
P7.1.1	1294	2100	0	160	1	121	PI control gain	INTEGER	2
P7.1.2	1295	2101	0	160	1	122	PI control itime	INTEGER	2
P7.1.3	1297	2870	0	160	1	123	PI process unit	BYTE	1
P7.1.4	1298	2871	0	160	1	124	PI process unit min.	DOUBLE	4
P7.1.5	1300	2872	0	160	1	125	PI process unit max.	DOUBLE	4
P7.1.6	1303	2850	0	160	1	126	PI error inversion	BOOLEAN	1
P7.1.7	1304	2851	0	160	1	127	PI dead band	DOUBLE	4
P7.1.8	1306	2852	0	160	1	128	PI dead band delay	INTEGER	2
P7.1.9	1311	2151	0	160	1	131	PI ramp time	INTEGER	2
P7.2.1.1	1307	2170	0	160	1	129	PI keypad setpoint 1	DOUBLE	4
P7.2.1.2	1309	2179	0	160	1	130	PI keypad setpoint 2	DOUBLE	4
P7.2.1.3	2466	NA	NA	166	1	90	PI wake up action	BYTE	1

Appendix J: Modbus RTU Commissioning

Menu item no	Modbus register	PROFIBUS PNU	PROFIBUS PNU subindex	EtherNet/IP class	EtherNet/IP instance	EtherNet/IP attribute	Parameter description	Data type	Length
P7.2.2.1	1312	2110	0	160	1	132	PI set point 1 source	BYTE	1
P7.2.2.2	1315	2136	0	160	1	133	PI set point 1 sleep enable	BOOLEAN	1
P7.2.2.3	1317	2138	0	160	1	134	PI set point 1 sleep delay	INTEGER	2
P7.2.2.4	1318	2139	0	160	1	135	PI set point 1 wake up level	DOUBLE	4
P7.2.2.5	1320	2154	0	160	1	136	PI set point 1 boost	BYTE	1
P7.2.2.6	2450	2137	0	166	1	91	PI set point 1 sleep level	DOUBLE	4
P7.2.2.7	1842	NA	NA	166	1	92	SP1 sleep mode over cycle time	BYTE	1
P7.2.2.8	1843	NA	NA	166	1	93	SP1 sleep mode max. cycle time	INTEGER	2
P7.2.3.1	1321	2116	0	160	1	137	PI set point 2 source	BYTE	1
P7.2.3.2	1324	2140	0	160	1	138	PI set point 2 sleep enable	BOOLEAN	1
P7.2.3.3	1326	2142	0	160	1	139	PI set point 2 sleep delay	INTEGER	2
P7.2.3.4	1327	2143	0	160	1	140	PI set point 2 wake up level	DOUBLE	4
P7.2.3.5	1329	2157	0	160	1	141	PI set point 2 boost	BYTE	1
P7.2.3.6	2452	2141	0	166	1	94	PI set point 2 sleep level	DOUBLE	4
P7.2.3.7	1844	NA	NA	166	1	95	SP2 sleep mode over cycle time	BYTE	1
P7.2.3.8	1845	NA	NA	166	1	96	SP2 sleep mode max cycle time	INTEGER	2
P7.3.1.1	1331	2153	0	160	1	142	PI feedback gain	INTEGER	2
P7.3.2.1	1332	2112	0	160	1	143	PI feedback 1 source	BYTE	1
P7.3.2.2	1333	2172	0	160	1	144	PI feedback 1 min.	INTEGER	2
P7.3.2.3	1334	2173	0	160	1	145	PI feedback 1 max.	INTEGER	2
P8.1.1	483	636	0	160	1	27	Damper start	BYTE	1
P8.1.2	484	118	0	160	1	28	Damper time-out	INTEGER	2
P8.1.3	485	118	1	160	1	29	Damper delay	INTEGER	2
P8.2.1	535	640	0	161	1	30	Fire mode function	BOOLEAN	1
P8.2.2	536	438	0	161	1	31	Fire mode ref. select function	BYTE	1
P8.2.3	537	28	2	161	1	32	Fire mode min. frequency	INTEGER	2
P8.2.4	565	1	5	161	1	33	Fire mode freq. ref. 1	INTEGER	2
P8.2.5	564	1	6	161	1	34	Fire mode freq. ref. 2	INTEGER	2
P8.2.6	2443	NA	NA	166	1	97	Fire mode test enable	BOOLEAN	1
P8.2.7	554	1	11	161	1	35	Smoke purge frequency	INTEGER	2
P8.3.1	317	840	28979	160	1	97	Broken belt protection	BYTE	1
P8.3.2	318	1013	0	160	1	98	Broken belt fnom. torque	INTEGER	2
P8.3.3	319	1013	1	160	1	99	Broken belt F0 torque	INTEGER	2
P8.3.4	320	1011	1	160	1	100	Broken belt time limit	INTEGER	2
P9.1.1	2468	NA	NA	166	1	98	Derag cycles	BYTE	1
P9.1.2	2469	NA	NA	166	1	99	Derag at start/stop	BYTE	1
P9.1.3	2470	NA	NA	166	1	100	Deragging run time	INTEGER	2
P9.1.4	2471	NA	NA	166	1	101	Derag speed	INTEGER	2
P9.1.5	2472	NA	NA	166	1	102	Derag off delay	INTEGER	2
P9.1.6	1879	NA	NA	166	1	103	Derag current	INTEGER	2
P9.2.1	1847	NA	NA	166	1	104	Valve start	BYTE	1
P9.2.2	1848	NA	NA	166	1	105	Valve time out	INTEGER	2
P9.2.3	1849	NA	NA	166	1	106	Valve delay	INTEGER	2
P9.2.4	2423	NA	NA	166	1	107	Back spin delay	INTEGER	2
P9.2.5	1813	NA	NA	166	1	108	Minimum run time	INTEGER	2
P9.2.6	1850	NA	NA	166	1	109	Min frequency ramp time	INTEGER	2
P9.3.1	2279	NA	NA	165	1	57	Multi-pump mode	BYTE	1
P9.3.2	2449	NA	NA	166	1	110	Number of drives	BYTE	1
P9.3.3	2278	NA	NA	165	1	56	Drive ID	BYTE	1

Appendix J: Modbus RTU Commissioning

Menu item no	Modbus register	PROFIBUS PNU	PROFIBUS PNU subindex	EtherNet/IP class	EtherNet/IP instance	EtherNet/IP attribute	Parameter description	Data type	Length
P9.3.4	2284	NA	NA	165	1	61	Regulation source	BYTE	1
P9.3.5	2458	NA	NA	166	1	111	PI bandwidth	DOUBLE	4
P9.3.6	2315	NA	NA	165	1	74	Staging frequency	INTEGER	2
P9.3.7	2316	NA	NA	165	1	75	De-staging frequency	INTEGER	2
P9.3.8	344	1923	0	161	1	43	Add/remove delay	INTEGER	2
P9.3.9	350	1909	0	161	1	44	Interlock enable	BYTE	1
P9.3.10	2285	NA	NA	165	1	62	Recovery method	BYTE	1
P9.3.11	2311	NA	NA	165	1	73	Add/remove drive selection	BYTE	1
P9.3.12	2280	NA	NA	165	1	58	Run time enable	BYTE	1
P9.3.13	2281	NA	NA	165	1	59	Run time limit	DOUBLE	4
P9.3.14	2283	NA	NA	165	1	60	Run time reset	BYTE	1
P9.3.15	2473	NA	NA	166	1	112	Master drive mode	BYTE	1
P9.3.16	2474	NA	NA	166	1	113	Master fixed speed	INTEGER	2
P9.3.17	2475	NA	NA	166	1	114	Master fixed speed delay	INTEGER	2
P9.4.1	2410	NA	NA	166	1	115	Pipe fill loss response	BYTE	1
P9.4.2	2406	NA	NA	166	1	116	Pipe fill loss detection method	BYTE	1
P9.4.3	2407	NA	NA	166	1	117	Pipe fill loss low level	INTEGER	2
P9.4.4	2409	NA	NA	166	1	118	Pipe fill loss low frequency	INTEGER	2
P9.4.5	1851	NA	NA	166	1	119	Pipe fill loss high level	INTEGER	2
P9.4.6	1852	NA	NA	166	1	120	Pipe fill loss high frequency	INTEGER	2
P9.4.7	2408	NA	NA	166	1	121	Pipe fill loss time	INTEGER	2
P9.4.8	2411	NA	NA	166	1	122	Pipe fill loss attempts	BYTE	1
P9.5.1	2428	NA	NA	166	1	123	Prime pump enable	BYTE	1
P9.5.2	2429	NA	NA	166	1	124	Prime pump level	DOUBLE	4
P9.5.3	2431	NA	NA	166	1	125	Prime pump frequency	INTEGER	2
P9.5.4	2432	NA	NA	166	1	126	Prime pump delay time	INTEGER	2
P9.5.5	2433	NA	NA	166	1	127	Prime pump loss of prime level	INTEGER	2
P9.5.6	2434	NA	NA	166	1	128	Prime pump level 2	DOUBLE	4
P9.5.7	2436	NA	NA	166	1	129	Prime pump frequency 2	INTEGER	2
P9.5.8	2437	NA	NA	166	1	130	Prime pump delay time 2	INTEGER	2
P9.5.9	2438	NA	NA	166	1	131	Prime pump loss of prime level 2	INTEGER	2
P9.6.1	1853	NA	NA	166	1	132	Broken pipe fault response	BYTE	1
P9.6.2	1854	NA	NA	166	1	133	Broken pipe level	INTEGER	2
P9.6.3	1856	NA	NA	166	1	134	Broken pipe frequency	INTEGER	2
P9.6.4	1855	NA	NA	166	1	135	Broken pipe delay	INTEGER	2
P10.1.1	2533	NA	NA	166	1	136	FB process data input 1 sel.	INTEGER	2
P10.1.2	2534	NA	NA	166	1	137	FB process data input 2 sel.	INTEGER	2
P10.1.3	2535	NA	NA	166	1	138	FB process data input 3 sel.	INTEGER	2
P10.1.4	2536	NA	NA	166	1	139	FB process data input 4 sel.	INTEGER	2
P10.1.5	2537	NA	NA	166	1	140	FB process data input 5 sel.	INTEGER	2
P10.1.6	2538	NA	NA	166	1	141	FB process data input 6 sel.	INTEGER	2
P10.1.7	2539	NA	NA	166	1	142	FB process data input 7 sel.	INTEGER	2
P10.1.8	2540	NA	NA	166	1	143	FB process data input 8 sel.	INTEGER	2
P10.2.1	1556	442	0	163	1	80	FB process data output 1 sel.	INTEGER	2
P10.2.2	1557	442	1	163	1	81	FB process data output 2 sel.	INTEGER	2
P10.2.3	1558	442	2	163	1	82	FB process data output 3 sel.	INTEGER	2
P10.2.4	1559	442	3	163	1	83	FB process data output 4 sel.	INTEGER	2
P10.2.5	1560	442	4	163	1	84	FB process data output 5 sel.	INTEGER	2
P10.2.6	1561	442	5	163	1	85	FB process data output 6 sel.	INTEGER	2

Appendix J: Modbus RTU Commissioning

Menu item no	Modbus register	PROFIBUS PNU	PROFIBUS PNU subindex	EtherNet/IP class	EtherNet/IP instance	EtherNet/IP attribute	Parameter description	Data type	Length
P10.2.7	1562	442	6	163	1	86	FB process data output 7 sel.	INTEGER	2
P10.2.8	1563	442	7	163	1	87	FB process data output 8 sel.	INTEGER	2
P10.3.1	2415	NA	NA	166	1	144	Standard status word bit0 function select	BYTE	1
P10.3.2	2416	NA	NA	166	1	145	Standard status word bit1 function select	BYTE	1
P10.3.3	2417	NA	NA	166	1	146	Standard status word bit2 function select	BYTE	1
P10.3.4	2418	NA	NA	166	1	147	Standard status word bit3 function select	BYTE	1
P10.3.5	2419	NA	NA	166	1	148	Standard status word bit4 function select	BYTE	1
P10.3.6	2420	NA	NA	166	1	149	Standard status word bit5 function select	BYTE	1
P10.3.7	2421	NA	NA	166	1	150	Standard status word bit6 function select	BYTE	1
P10.3.8	2422	NA	NA	166	1	151	Standard status word bit7 function select	BYTE	1
P11.1.1	586	3220	0	161	1	45	Serial communication	BYTE	1
P11.2.1	587	3221	0	161	1	46	Slave address	BYTE	1
P11.2.2	584	3222	0	161	1	47	Baud rate	BYTE	1
P11.2.3	585	3224	0	161	1	48	Parity type	BYTE	1
P11.2.4	588	3225	0	161	1	49	Modbus RTU protocol status	BYTE	1
P11.2.5	593	3290	0	161	1	50	Comm timeout modbus RTU	INTEGER	2
P11.2.6	2516	NA	NA	166	1	152	Modbus RTU fault response	BYTE	1
P11.3.1	594	NA	NA	166	1	153	MSTP baud rate	BYTE	1
P11.3.2	595	NA	NA	166	1	154	MSTP device address	BYTE	1
P11.3.3	596	NA	NA	166	1	155	MSTP instance number	DOUBLE	4
P11.3.4	598	NA	NA	166	1	156	MSTP comm time-out	INTEGER	2
P11.3.5	599	NA	NA	166	1	157	MSTP protocol status	BYTE	1
P11.3.6	600	NA	NA	166	1	158	MSTP fault code	BYTE	1
P11.3.7	2526	NA	NA	166	1	159	MSTP fault response	BYTE	1
P11.3.8	1537	NA	NA	166	1	160	MSTP max. master	BYTE	1
P11.4.1	1726	NA	NA	166	1	161	SA bus device address	BYTE	1
P11.4.2	1727	NA	NA	166	1	162	SA bus baud rate	BYTE	1
P11.4.3	1728	NA	NA	166	1	163	SA bus instance number	DOUBLE	4
P11.4.4	1730	NA	NA	166	1	164	SA bus comm. time-out	INTEGER	2
P11.4.5	1731	NA	NA	166	1	165	SA bus protocol status	BYTE	1
P11.4.6	1732	NA	NA	166	1	166	SA bus fault response	BYTE	1
P11.5.1	2630	NA	NA	166	1	167	Parameter access	INTEGER	2
P11.5.2	2631	NA	NA	166	1	168	Process data access	INTEGER	2
P11.5.3	2632	NA	NA	166	1	169	Fault situation counter	INTEGER	2
P11.5.4	2609	NA	NA	166	1	170	Board status	BYTE	1
P11.5.5	2610	NA	NA	166	1	171	Firmware version	INTEGER	4
P11.5.6	2612	NA	NA	166	1	172	Protocol status	BYTE	1
P11.6.1	1895	NA	NA	166	1	173	Blue tooth enable	BYTE	1
P11.6.2	2920	NA	NA	166	1	174	Blue tooth broadcast mode	BYTE	1
P11.6.3	2935	NA	NA	166	1	175	Blue tooth pairing reset	BYTE	1
P12.1.1	1500	3249	0	161	1	51	IP address mode	BOOLEAN	1
P12.1.2	1507	NA	NA	166	1	176	Active IP address	BYTE	4
P12.1.3	1509	NA	NA	166	1	177	Active subnet mask	BYTE	4
P12.1.4	1511	NA	NA	166	1	178	Active default gateway	BYTE	4

Appendix J: Modbus RTU Commissioning

Menu item no	Modbus register	PROFIBUS PNU	PROFIBUS PNU subindex	EtherNet/IP class	EtherNet/IP instance	EtherNet/IP attribute	Parameter description	Data type	Length
P12.1.5	1513	NA	NA	166	1	179	MAC address	BYTE	6
P12.1.6	1501	NA	NA	166	1	180	Static IP address	BYTE	4
P12.1.7	1503	NA	NA	166	1	181	Static subnet mask	BYTE	4
P12.1.8	1505	NA	NA	166	1	182	Static default gateway	BYTE	4
P12.1.9	611	NA	NA	41	1	109	EtherNet communication timeout	INTEGER	2
P12.2.1	68	NA	NA	166	1	183	Trusted IP white list	BYTE	12
P12.2.2	76	NA	NA	166	1	184	Trusted IP filter enable	BYTE	1
P12.3.1	1942	NA	NA	166	1	185	Modbus TCP enable	BOOLEAN	1
P12.3.2	609	NA	NA	161	1	52	Modbus TCP connection limit	BYTE	1
P12.3.3	610	NA	NA	161	1	53	Modbus TCP unit identifier number	BYTE	1
P12.3.4	612	3235	0	161	1	55	Modbus TCP protocol status	BYTE	1
P12.3.5	2517	NA	NA	166	1	186	Modbus TCP fault response	BYTE	1
P12.4.1	1997	NA	NA	166	1	187	Ethernet based protocol select	BYTE	1
P12.4.2	608	NA	NA	164	1	10	Ethernet IP protocol status	BYTE	1
P12.4.3	2518	NA	NA	166	1	188	Ethernet IP fault response	BYTE	1
P12.5.1	1733	NA	NA	166	1	189	BACnet IP UDP port number	INTEGER	2
P12.5.2	1734	NA	NA	166	1	190	BACnet IP foreign device	BYTE	1
P12.5.3	1735	NA	NA	166	1	191	BACnet IP BBMD IP	BYTE	4
P12.5.4	1737	NA	NA	166	1	192	BACnet IP BBMD port	INTEGER	2
P12.5.5	1738	NA	NA	166	1	193	BACnet IP registration interval	INTEGER	2
P12.5.6	1739	NA	NA	166	1	194	BACnet IP comm. time-out	INTEGER	2
P12.5.7	1740	NA	NA	166	1	195	BACnet IP protocol status	BYTE	1
P12.5.8	1741	NA	NA	166	1	196	BACnet IP fault behavior	BYTE	1
P12.5.9	1742	NA	NA	166	1	197	BACnetIP instance number	DOUBLE	4
P12.6.1	2915	NA	NA	166	1	198	WebUI protocol status	BYTE	1
P12.6.2	2916	NA	NA	166	1	199	WebUI fault response	BYTE	1
P12.6.3	2919	NA	NA	166	1	200	Web UI communication time-out	INTEGER	2
P12.6.4	2921	NA	NA	166	1	201	WebUI enable	BYTE	1
P12.7.1	3001	NA	NA	166	1	202	IOT enable	BOOLEAN	1
P12.7.2	3002	NA	NA	166	1	203	IOT connection status	BOOLEAN	1
P12.7.3	3003	NA	NA	166	1	204	Proxy enable	BOOLEAN	1
P12.8.1	3178	NA	NA	166	1	205	SNTP enable	BYTE	1
P12.8.2	3188	NA	NA	166	1	206	SNTP server status	BYTE	1
P12.8.3	3179	NA	NA	166	1	207	SNTP server 1	BYTE	4
P12.8.4	3181	NA	NA	166	1	208	SNTP server 2	BYTE	4
P12.8.5	3183	NA	NA	166	1	209	SNTP server 3	BYTE	4
P13.1.1	340	323	0	162	1	13	Language	BYTE	1
P13.1.2	142	256	0	160	1	26	Application	BYTE	1
P13.1.3	619	970	0	162	1	14	Parameter sets	BYTE	1
P13.1.4	620	302	0	162	1	15	Up to keypad	BOOLEAN	1
P13.1.5	621	302	1	162	1	16	Down from keypad	BYTE	1
P13.1.6	623	305	0	162	1	17	Parameter comparison	BYTE	1
P13.1.7	624	320	0	162	1	18	Parameter lock PIN	INTEGER	2
P13.1.8	625	625	0	162	1	19	Keypad parameter lock	BOOLEAN	1
P13.1.9	626	NA	NA	162	1	20	Startup wizard	BOOLEAN	1
P13.2.1	1875	NA	NA	166	1	210	Local default page	BYTE	1
P13.2.2	1876	NA	NA	166	1	211	Local monitor parameter set	BYTE	3
P13.2.3	628	326	0	162	1	22	Default page	BYTE	1
P13.2.4	629	330	0	162	1	23	Time-out time	INTEGER	2

Appendix J: Modbus RTU Commissioning

Menu item no	Modbus register	PROFIBUS PNU	PROFIBUS PNU subindex	EtherNet/IP class	EtherNet/IP instance	EtherNet/IP attribute	Parameter description	Data type	Length
P13.2.5	630	324	0	162	1	24	Contrast adjust	BYTE	1
P13.2.6	631	330	1	162	1	25	Backlight time	INTEGER	2
P13.2.7	632	627	0	162	1	26	Fan control	BYTE	1
P13.2.8	633	362	0	162	1	27	Keypad ACK time-out	INTEGER	2
P13.2.9	634	3291	0	162	1	28	Keypad retry number	BYTE	1
P13.3.1	2424	NA	NA	166	1	212	Output display unit	BYTE	1
P13.3.2	2460	NA	NA	166	1	213	Output display unit min.	DOUBLE	4
P13.3.3	2425	NA	NA	166	1	214	Output display unit max.	DOUBLE	4
P13.4.1	640	207	2	161	1	58	Keypad software version	INTEGER	4
P13.4.2	642	206	0	162	1	1	Motor control software version	INTEGER	4
P13.4.3	644	207	1	1	1	4	Application software version	INTEGER	4
P13.4.4	1714	NA	NA	166	1	215	Software bundle version		20
P13.5.1	648	NA	NA	1	1	6	Serial number	DOUBLE	4
P13.5.2	627	328	0	162	1	21	Multi-monitor set	BOOLEAN	1
P13.5.3	75	NA	NA	166	1	216	Keypad lock PIN	INTEGER	2
P13.5.4	2922	NA	NA	166	1	217	Drive Application name		20
P13.6.1	601	520	2	162	1	6	Total MWh count	DOUBLE	4
P13.6.2	603	522	0	162	1	7	Total power day count	INTEGER	2
P13.6.3	606	821	1	162	1	8	Total power hr. count	DOUBLE	4
P13.6.4	1872	NA	NA	166	1	218	Total motor hr. count	DOUBLE	4
P13.6.5	604	806	0	162	1	9	Trip MWh count	DOUBLE	4
P13.6.6	639	322	4	162	1	12	Clear trip MWh count	BYTE	1
P13.6.7	636	870	0	162	1	10	Trip power day count	INTEGER	2
P13.6.8	637	871	0	162	1	11	Trip power hr. count	DOUBLE	4
B2.1.1.1	883	710	1	162	1	87	Board status	BYTE	1
B2.1.1.2	1064	NA	NA	162	1	88	Firmware version	INTEGER	4
B2.1.1.3	2131	NA	NA	164	1	36	Protocol status	BYTE	1
B2.1.1.4	2633	NA	NA	166	1	219	PDP-telegram selection	INTEGER	2
B2.1.1.5	2634	NA	NA	166	1	220	Fault counter PDP	INTEGER	2
B2.1.1.6	2635	NA	NA	166	1	221	Fault situations max.	INTEGER	4
B2.1.1.7	2637	NA	NA	166	1	222	PDP-profil number	INTEGER	2
B2.1.1.8	2638	NA	NA	166	1	223	PDP-control word	INTEGER	2
B2.1.1.9	2639	NA	NA	166	1	224	PDP-status word	INTEGER	2
B2.1.2.1	2621	NA	NA	166	1	225	PDP-maxblocklength	BYTE	1
B2.1.2.2	2622	NA	NA	166	1	226	PDP-noofmultiparameter	BYTE	1
B2.1.2.3	2623	NA	NA	166	1	227	PDP-maxlatency	BYTE	1
B2.1.3.1	2624	NA	NA	166	1	228	PDP-DO manufacturer	INTEGER	2
B2.1.3.2	1451	NA	NA	1	1	3	PDP-DO device type	INTEGER	2
B2.1.3.3	2625	NA	NA	166	1	229	PDP-DO FW-interface	INTEGER	2
B2.1.3.4	2640	NA	NA	166	1	230	PDP-DO FW-year	INTEGER	2
B2.1.3.5	2641	NA	NA	166	1	231	PDP-DO FW-daymonth	INTEGER	2
B2.1.3.6	2628	NA	NA	166	1	232	PDP-DO noofdos	BYTE	1
B2.1.3.7	2629	NA	NA	166	1	233	PDP-DO subclass	BYTE	1
B2.2.1	1242	3201	100	163	1	41	Slave address	BYTE	1
B2.2.2	1245	3200	100	163	1	42	Operate mode	BYTE	1
B2.2.3	2642	NA	NA	166	1	234	Parameter access	INTEGER	2
B2.2.4	2643	NA	NA	166	1	235	Process data access	INTEGER	2
B2.2.5	2644	NA	NA	166	1	236	Fault situation counter	INTEGER	2
B2.2.6	619	970	0	162	1	14	Parameter sets	BYTE	1

Appendix J: Modbus RTU Commissioning

Menu item no	Modbus register	PROFIBUS PNU	PROFIBUS PNU subindex	EtherNet/IP class	EtherNet/IP instance	EtherNet/IP attribute	Parameter description	Data type	Length
B3.1.1	883	710	1	162	1	87	Board status	BYTE	1
B3.1.2	1064	NA	NA	162	1	88	Firmware version	INTEGER	4
B3.1.3	2132	NA	NA	164	1	37	Protocol status	BYTE	1
B3.2.1	2133	NA	NA	164	1	38	Node ID	BYTE	1
B3.2.2	2134	NA	NA	164	1	39	Baud rate	BYTE	1
B3.2.3	2135	NA	NA	164	1	40	Operate mode	BYTE	1
B3.2.4	2519	NA	NA	166	1	237	Comm. card FB fault response	BYTE	1
O1	1	502	0	160	1	1	Output frequency	INTEGER	2
O2	24	1	0	160	1	2	Freq. reference	INTEGER	2
O3	2	503	0	4	70	3	Motor speed	INTEGER	2
O4	3	504	0	160	1	4	Motor current	INTEGER	2
O5	4	507	0	160	1	5	Motor torque	INTEGER	2
O6	5	513	1	160	1	6	Motor power	INTEGER	2
O7	6	501	0	160	1	7	Motor voltage	INTEGER	2
O8	7	501	1	160	1	8	DC-link voltage	INTEGER	2
O9	8	822	6	160	1	9	Unit temperature	INTEGER	2
O10	9	822	4	160	1	10	Motor temperature	INTEGER	2
R11	141	1	8	160	1	66	Keypad reference	INTEGER	2
R12	1307	2170	0	160	1	129	PI keypad setpoint 1	DOUBLE	4
R13	1309	2179	0	160	1	130	PI keypad setpoint 2	DOUBLE	4
P13.1.7	624	320	0	162	1	18	Parameter lock PIN	INTEGER	2
P1.1	101	20	0	160	1	73	Min frequency	INTEGER	2
P1.2	102	20	1	160	1	74	Max frequency	INTEGER	2
P1.6	486	210	0	40	1	6	Motor nom. current	INTEGER	2
P1.7	489	217	0	40	1	15	Motor nom. speed	INTEGER	2
P1.8	490	215	0	161	1	38	Motor PF	INTEGER	2
P1.9	487	211	0	40	1	7	Motor nom. voltage	INTEGER	2
P1.10	488	216	0	161	1	40	Motor nom. frequency	INTEGER	2
P1.3	103	130	0	160	1	75	Accel. time 1	INTEGER	2
P1.4	104	134	0	160	1	76	Decel. time 1	INTEGER	2
P1.13	135	408	0	160	1	63	Remote control place	BYTE	1
P1.14	137	437	0	160	1	65	Remote reference	BYTE	1
P13.5.3	75	NA	NA	166	1	216	Keypad lock PIN	INTEGER	2
P11.6.1	1895	NA	NA	166	1	173	Blue tooth enable	BYTE	1
P7.1.3	1297	2870	0	160	1	123	PI process unit	BYTE	1
P7.1.4	1298	2871	0	160	1	124	PI process unit min.	DOUBLE	4
P7.1.5	1300	2872	0	160	1	125	PI process unit max.	DOUBLE	4
P7.2.2.1	1312	2110	0	160	1	132	PI setpoint 1 source	BYTE	1
P7.2.1.1	1307	2170	0	160	1	129	PI keypad setpoint 1	DOUBLE	4
P7.3.2.1	1332	2112	0	160	1	143	PI feedback 1 source	BYTE	1
P7.2.2.6	2450	2137	0	166	1	91	PI set point 1 sleep level	DOUBLE	4
P7.2.2.3	1317	2138	0	160	1	134	PI set point 1 sleep delay	INTEGER	2
P7.2.1.3	2466	NA	NA	166	1	90	PI wake up action	BYTE	1
P7.2.2.4	1318	2139	0	160	1	135	PI set point 1 wake up level	DOUBLE	4
P7.1.3	1297	2870	0	160	1	123	PI process unit	BYTE	1
P7.1.4	1298	2871	0	160	1	124	PI process unit min.	DOUBLE	4
P7.1.5	1300	2872	0	160	1	125	PI process unit max.	DOUBLE	4
P7.2.2.1	1312	2110	0	160	1	132	PI set point 1 source	BYTE	1
P7.2.1.1	1307	2170	0	160	1	129	PI keypad setpoint 1	DOUBLE	4

Appendix J: Modbus RTU Commissioning

Menu item no	Modbus register	PROFIBUS PNU	PROFIBUS PNU subindex	EtherNet/IP class	EtherNet/IP instance	EtherNet/IP attribute	Parameter description	Data type	Length
P7.3.2.1	1332	2112	0	160	1	143	PI feedback 1 source	BYTE	1
P7.2.2.6	2450	2137	0	166	1	91	PI set point 1 sleep level	DOUBLE	4
P7.2.2.3	1317	2138	0	160	1	134	PI set point 1 sleep delay	INTEGER	2
P7.2.1.3	2466	NA	NA	166	1	90	PI wake up action	BYTE	1
P7.2.2.4	1318	2139	0	160	1	135	PI set point 1 wake up level	DOUBLE	4
P8.2.2	536	438	0	161	1	31	Fire mode ref. select function	BYTE	1
P8.2.3	537	28	2	161	1	32	Fire mode min. frequency	INTEGER	2
P4.5.1	776	NA	NA	NA	1	NA	IGBT Temperature	INTEGER	2
P4.5.2	1771	NA	NA	NA	1	NA	Foldback status	BYTE	1
P4.5.3	1772	NA	NA	NA	1	NA	Foldback output frequency	INTEGER	2
P4.5.4	1773	NA	NA	NA	1	NA	Foldback output speed	INTEGER	2
P4.5.5	1774	NA	NA	NA	1	NA	Foldback enable	BYTE	1
P4.5.6	1775	NA	NA	NA	1	NA	Foldback temperature	INTEGER	2
P4.5.7	1776	NA	NA	NA	1	NA	Recovering temperature	INTEGER	2
P4.5.8	1777	NA	NA	NA	1	NA	Foldback speed reduce rate	INTEGER	2
P4.5.9	1778	NA	NA	NA	1	NA	Foldback minimum speed	INTEGER	2
P4.5.10	1779	NA	NA	NA	1	NA	Foldback fault timeout	INTEGER	2

Appendix K: Temperature Derating

Temperature Derating

When using the EVM series drive at elevated temperatures or elevation, derating may be required to size the drive appropriately to maintain proper cooling.

*4 kHz is default switching frequency

Should any of the below be true for given application / VFD location, please reach out to your AE or Sales rep for assistance.

1. Drive is to operate at or above 50C for a continuous basis
 - a. 575V drives- 40C
2. Altitude above 1000 m
 - a. 1% derating per 100m up to 2000m (UL listing)
 - b. up to 4000m (without UL listing)

Cold Weather Mode

The EVM series variable frequency drives (VFD) have an integrated cold weather functionality that will give them the ability to operate below the lower limit of the ambient rated temperature. The functionality provides a safe and cost-effective way to perform warming of both the motor and the drive inside enclosure.

The EVM series VFDs have a parameter group that supplies a selectable AC voltage to the motor at a very low frequency for a desired period to allow the drive to warm up in cold environments, it also lowers the temperature fault level to help. This design uses the current draw through the IGBT modules to warm up the unit temperature by sending a 0.5Hz output frequency to the motor. The drives standard low temperature fault point is $-10^{\circ}\text{C}/14^{\circ}\text{F}$, which in most applications is sufficient. In extreme temperature regions that often reach below this point, this can cause a fault, preventing operation of the drive. With the cold weather functionality enabled, the trip point is taken from a $-10^{\circ}\text{C}/14^{\circ}\text{F}$ fault level and moves it down to $-30^{\circ}\text{C}/-22^{\circ}\text{F}$ with an alarm trip point at $-20^{\circ}\text{C}/-4^{\circ}\text{F}$. Therefore, the adjustable frequency drive will start the motor in a normal operational mode when the unit temperature is above the $-20^{\circ}\text{C}/-4^{\circ}\text{F}$ level. If the drives unit temp is between $-20^{\circ}\text{C}/-4^{\circ}\text{F}$ and $-30^{\circ}\text{C}/-22^{\circ}\text{F}$ and the drive is stopped, when the run command is given the drive will go into the cold weather warm up feature to enable the motor to start when it reaches $-20^{\circ}\text{C}/-4^{\circ}\text{F}$, using the previously mentioned 0.5Hz frequency and a user settable Voltage level.

Guidelines

- P6.2.13: Cold Weather Voltage Level
 - Default Setting: 2.0% of the motor rated voltage.
 - Range: 0% - 20% (User-configurable based on ambient conditions).
 - Recommended Setting: Set the lowest level that effectively warms the drive and motor without excessive wear on motor windings (e.g., 5-10% for extreme cold).
- P6.2.14: Cold Weather Time Out
 - Default Setting: 3 minutes.
 - Range: 0 to 10 minutes.
 - Recommended Setting: Adjust based on how quickly the drive needs to reach operational temperature (e.g., 5-7 minutes for colder environments).

Step 1: Save and Confirm Settings

1. Press Save or Apply after configuring each parameter.
2. Navigate to the Diagnostics Menu and check the following indicators:
 - a. Cold Weather Mode: Enabled.
 - b. Unit Temperature: Monitored and within the operational range.

Step 2: Test the Configuration

1. Simulate Cold Conditions:
 - a. Place the drive in an environment below -20°C and monitor behavior.
2. Observe Warm-Up Sequence:
 - a. Upon a run command, verify that the drive outputs a 0.5 Hz frequency and the set voltage level.
 - b. Ensure the drive ramps up to the reference value once the temperature exceeds -20°C .

Appendix L: Advanced Features

3. Check Alarms:

- a. Alarm 90 (Cold Weather Warm) should activate during warm-up mode.
- b. If the temperature does not rise above -20°C within the set time, the drive should display Fault F13: Under Temp Fault.

Foldback

To protect the drive components or the compressor, the compressor speed will 'foldback' or slow down to help reduce risk to components. The foldback event(s) will be flagged in the drive's Modbus registers. This will allow the operating system to respond and mitigate the conditions causing foldback.

Guidelines

- The compressor speed will be reduced at the rate of 20 rpm/s if the inverter (IGBT) temperature is greater than or equal to the foldback temperature.
- The compressor will remain at the same speed if the inverter temperature is greater than or equal to the recovering temperature, and lower than the foldback temperature.
- The compressor speed will recover to the commanded speed if the inverter temperature is less than the recovering temperature.
- The compressor will trip if the compressor load is not recovered and continues to exceed the foldback limit in one of the conditions below:
 - After the compressor's running speed has reached 2100 rpm and then stays at 2100 rpm for 30 seconds or longer.
 - If the original running speed was already less than 2100 rpm for 30 seconds or longer.

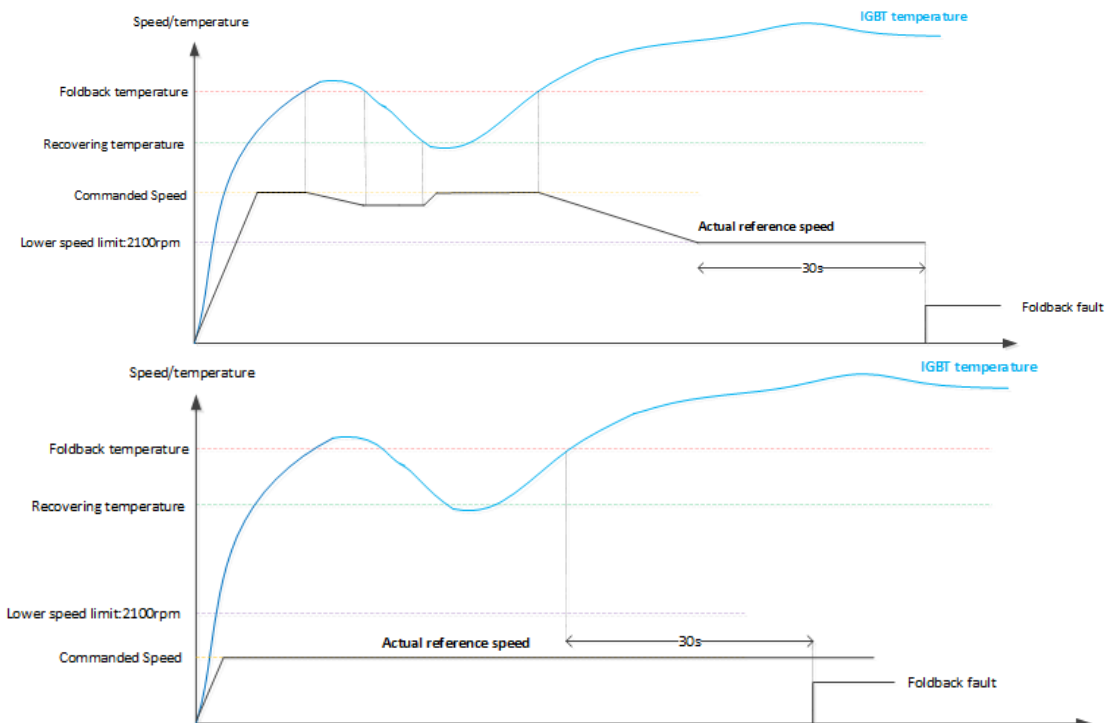

Appendix M: Accessories

*Remote Keypad Mounting kit does not include remote keypad.

EVM Accessories	
EVM NEMA 1 Conversion Kits	
Description	Catalog Number
EVM FR1 NEMA 1 Kit	962-0009-00
EVM FR2 NEMA 1 Kit	962-0010-00
EVM FR3 NEMA 1 Kit	962-0011-00
EVM FR4 NEMA 1 Kit	962-0012-00
EVM FR1 Plenum Rated NEMA 1 Kit	962-0054-00
EVM FR2 Plenum Rated NEMA 1 Kit	962-0055-00
EVM FR3 Plenum Rated NEMA 1 Kit	962-0056-00
EVM FR4 Plenum Rated NEMA 1 Kit	962-0057-00
EVM Communication Card Kits	
Description	Catalog Number
EVM ProfiBus DP Communications Card	962-0053-00
EVM CANopen Communications Card	962-0008-00
EVM Remote Keypad Kit	
Description	Catalog Number
Remote Keypad	962-0013-00
1m Remote Keypad cable	929-0016-00
3m Remote Keypad cable	929-0017-00
Remote Keypad Mounting Holder Only	962-0014-00
EVM/EVH Remote Keypad Mounting Kit (w/3m cable) *	962-0015-00
EVM Demo Unit	
Description	Catalog Number
Demo Case EVM Pro	962-0058-00
EVM/EVH Software Cable (USB to RS485)	
Description	Catalog Number
EVM/EVH Software Cable (USB to RS485)	929-0015-00
EVM Ferrite Core Kit	
Description	Catalog Number
EVM 575V FR3/FR4 NON-EMI Ferrite Core Kit	962-0060-00