



BULLETIN

AE4-1400 R2

February 2015

1 to 5 Ton ZP*K6 R-410A Copeland Scroll™ Compressors





TABLE OF CONTENTS

<u>Section</u>	<u>Page</u>	<u>Section</u>	<u>Page</u>
Safety		Suction & Discharge Fittings.....	9
Safety Instructions	2	System Tubing Stress	9
Safety Icon Explanation	2	Three Phase Scroll Electrical Phasing	10
Instructions Pertaining to Risk of Electrical Shock, Fire, or Injury to Persons	3	Brief Power Interruptions.....	10
Safety Statements.....	3	Tandem Compressors.....	10
Introduction	4	Maximum Tilt Angle	10
Nomenclature	4	Application Tests	
Application Considerations		Application Summary.....	10
Internal Pressure Relief Valve	4	Continuous Floodback Test.....	11
Discharge Temperature Protection	4	Field Application Test.....	11
Heat Pump Protection.....	5	Assembly Line Procedures	
Discharge Line Thermostat	5	Installing the Compressor.....	11
Air-Conditioning Unit Protection	5	Suction Funnel	12
High Pressure Control.....	5	Assembly Line Brazing Procedure	12
Shut Down Device	5	Pressure Testing.....	12
Motor Overload Protection	5	Assembly Line System Charging Procedure	12
Operating Envelope	6	High Potential (AC Hipot) Testing	12
Power Supply.....	6	Final Run Test	13
Accumulators	6	Unbrazing System Components.....	13
Screens.....	6	Service Procedures	
Crankcase Heat-Single Phase	6	Copeland Scroll Functional Check	13
Crankcase Heat-Three Phase.....	7	Compressor Replacement After Motor Burn	14
Minimum Run Time	7	Start Up of a New or Replacement Compressor	14
Reversing Valves	7	Figures & Tables	
Low Ambient Cut-Out.....	7	R410A Scroll Operating Envelope	15
Oil Type.....	7	Oil Dilution Chart	16
Contaminant Control	8	Time Delay Wiring	17
Long Line Sets/High Refrigerant Charge.....	8	Compressor Electrical Connection	17
Discharge Mufflers	8	Crankcase Heater	18
Air-Conditioning System Suction Line Noise & Vibration.....	8	Scroll Suction Tube Brazing.....	19
Mounting Parts.....	9	How a Scroll Works	20
Single Phase Starting Characteristics	9	Suction Funnel Diagram.....	21
PTC Start Components.....	9	Field Application Test.....	22
Electrical Connections.....	9	Design Configurations	22
Deep Vacuum Operation.....	9	Compressor Refrigerant Charge Limits	22
		Compressor Accessories.....	23





Safety Instructions

Copeland Scroll™ compressors are manufactured according to the latest U.S. and European Safety Standards. Particular emphasis has been placed on the user's safety. Safety icons are explained below and safety instructions applicable to the products in this bulletin are grouped on Page 3. These instructions should be retained throughout the lifetime of the compressor. **You are strongly advised to follow these safety instructions.**

Safety Icon Explanation

	DANGER indicates a hazardous situation which, if not avoided, will result in death or serious injury.
	WARNING indicates a hazardous situation which, if not avoided, could result in death or serious injury.
	CAUTION, used with the safety alert symbol, indicates a hazardous situation which, if not avoided, could result in minor or moderate injury.
	NOTICE is used to address practices not related to personal injury.
	CAUTION, without the safety alert symbol, is used to address practices not related to personal injury.

Instructions Pertaining to Risk of Electrical Shock, Fire, or Injury to Persons

	<p>ELECTRICAL SHOCK HAZARD</p> <ul style="list-style-type: none"> • Disconnect and lock out power before servicing. • Discharge all capacitors before servicing. • Use compressor with grounded system only. • Molded electrical plug must be used in all ZP*K6 applications. • Refer to original equipment wiring diagrams. • Electrical connections must be made by qualified electrical personnel. • Failure to follow these warnings could result in serious personal injury.
	<p>PRESSURIZED SYSTEM HAZARD</p> <ul style="list-style-type: none"> • System contains refrigerant and oil under pressure. • Remove refrigerant from both the high and low compressor side before removing compressor. • Use appropriate back up wrenches on rotalock fittings when servicing. • Never install a system and leave it unattended when it has no charge, a holding charge, or with the service valves closed without electrically locking out the system. • Use only approved refrigerants and refrigeration oils. • Personal safety equipment must be used. • Failure to follow these warnings could result in serious personal injury.
	<p>BURN HAZARD</p> <ul style="list-style-type: none"> • Do not touch the compressor until it has cooled down. • Ensure that materials and wiring do not touch high temperature areas of the compressor. • Use caution when brazing system components. • Personal safety equipment must be used. • Failure to follow these warnings could result in serious personal injury or property damage.
	<p>COMPRESSOR HANDLING</p> <ul style="list-style-type: none"> • Use the appropriate lifting devices to move compressors. • Personal safety equipment must be used. • Failure to follow these warnings could result in personal injury or property damage.

Safety Statements

- Refrigerant compressors must be employed only for their intended use.
- **Only qualified and authorized HVAC or refrigeration personnel are permitted to install, commission and maintain this equipment.**
- **Electrical connections must be made by qualified electrical personnel.**
- All valid standards and codes for installing, servicing, and maintaining electrical and refrigeration equipment must be observed.

Introduction

ZP*K6 Copeland Scroll™ compressors are designed with a number of patented features to deliver a 2 to 4% efficiency increase over the prior generation of Copeland Scroll compressors. ZP*K6 is designed to help OEMs meet 2015 regional efficiency standards. This bulletin describes the operating characteristics, design features, and application requirements for the ZP*K6 family of compressors.

For additional information, please refer to our Online Product Information, accessible from the Emerson Climate Technologies website at www.emersonclimate.com. Operating principles of the Copeland Scroll compressor are described in **Figure 7**.

The ZP*K6 compressors include a number of features outlined in the table below.

Nomenclature

The model numbers of the Copeland Scroll compressors include the approximate nominal 60 Hz capacity at standard operating conditions. An example would be the ZP31K6E-PFV, which has 31,500 Btu/hr (9.2kW) cooling capacity at the AHRI high temperature air conditioning rating point when operated at 60 Hz. Please refer to Online Product Information at www.emersonclimate.com for details.

Application Considerations

The following application guidelines should be considered in the design of a system using ZP*K6 scroll compressors. Some of this information is recommended, whereas other guidelines must be followed. The Application Engineering department will always welcome suggestions that will help improve these types of documents.

Internal Pressure Relief (IPR) Valve

The internal pressure relief valve is located between the high and low side of the compressor. It is designed to open when the discharge-to-suction pressure differential exceeds 550 to 625 psid (38-43 bar). When the valve opens, hot discharge gas is routed back into the area of the motor protector to cause a trip. During fan failure testing, system behavior and operating pressures will depend on the type of refrigerant metering device. Fixed orifice devices may flood the compressor with refrigerant, and thermostatic expansion devices will attempt to control superheat and result in higher compressor top cap temperatures. Fan failure testing or loss of air flow in both cooling and heating should be evaluated by the system designer to assure that the compressor and system are protected from abnormally high pressures.

Discharge Temperature Protection



Compressor top cap temperatures can be very hot. Care must be taken to ensure that wiring or other materials which could be damaged by these temperatures do not come into contact with these potentially hot areas.

The Therm-O-Disc™ or T-O-D is a temperature-sensitive snap disc device located between the high and low pressure side of the muffler plate. It is designed to open and route excessively hot discharge gas back to the motor protector when the internal discharge gas exceeds 275°F (135°C). During a situation such as loss of charge, the compressor will be protected for some time while it trips the protector. However, as refrigerant leaks out, the mass flow and the amperage draw are reduced and the scrolls will start to overheat. A low pressure control is recommended for loss of charge

ZP*K6 Family Features

Model	Motor Frame Size*	Application				Suction Funnel	Transient Sound Solution	Improved Sound Quality	Electrical Connections
		IPR AC	TOD HP						
ZP10-31K6	53	X	X	X	X	X	X		Molded Plug
ZP34-54K6	63	X	X	X	X	X	X	X	Molded Plug

* Approximate Shell Diameter (e.g. 53 = 5.5", 63 = 6.5")

protection for the highest level of system protection. The low pressure cut-out can provide protection against indoor blower failure in cooling, outdoor fan failure in heating, closed liquid or suction line service valves, or a blocked liquid line screen, filter, orifice, or TXV. All of these can starve the compressor of refrigerant and result in compressor failure. The low pressure cut-out should have a manual reset feature for the highest level of system protection. If a compressor is allowed to cycle after a fault is detected, there is a high probability that the compressor will be damaged and the system contaminated with debris from the failed compressor and decomposed oil. If current monitoring of the compressor is available, the system controller can take advantage of the compressor TOD and internal protector operation. The controller can lock out the compressor if current draw is not coincident with the contactor energizing, implying that the compressor has shut off on its internal protector. This will prevent unnecessary compressor cycling on a fault condition until corrective action can be taken.

Heat Pump Protection

A low pressure control is highly recommended for loss of charge protection and other system fault conditions that may result in very low evaporating temperatures. Even though these compressors have internal discharge temperature protection, loss of system charge will result in overheating and cycling of the motor overload. Prolonged operation in this manner could result in oil pump out and eventual bearing failure. A cut out setting no lower than 20 psig (1.4 bar) is recommended.

Operation near -25°F (-32°C) saturated suction temperature is clearly outside the approved operating envelope shown in Figure 1. However, heat pumps in some geographical areas have to operate in this range because of the low ambient temperatures. This is acceptable as long as the condensing temperature is not above 90°F (32°C) and the resulting discharge temperature is below 275°F (135°C). Some liquid floodback to the compressor under these conditions can help keep the discharge temperature under control.

Discharge Line Thermostat

Some systems, such as air-to-air heat pumps, may not work with the above low pressure control arrangement. A discharge line thermostat set to shut the compressor off before the discharge temperature exceeds 260°F (125°C) may have to be used to achieve the same protection. Mount the discharge thermostat as close as

possible to the compressor discharge fitting and insulate well. See **Table 5** for recommended Emerson Climate Technologies part numbers.

Air Conditioning Unit Protection

Air conditioning units can be protected against high discharge temperatures through a low pressure control in the suction line. Testing has shown that a cut out setting of not lower than 55 psig (3.8 bar) will adequately protect the compressor against overheating from the aforementioned loss of charge, blower failure in a TXV system, etc. A higher level of protection is achieved if the low pressure control is set to cut out around 95 psig (6.7 bar) to prevent evaporator coil icing. The cut in setting can be as high as 180 psig (12.5 bar) to prevent rapid recycling in case of refrigerant loss. If an electronic controller is used, the system can be locked out after repeated low pressure trips.

High Pressure Control

If a high pressure control is used with these compressors **the recommended maximum cut out setting is 650 psig (45 bar)**. The high pressure control should have a manual reset feature for the highest level of system protection. **It is not recommended to use the compressor to test the high pressure switch function during the assembly line test.**

Shut Down Device

ZP*K6 compressors employ a unitary shutdown device to manage the flow of top-cap discharge gas back through the scrolls after shutdown. Development testing should include a review of the shutdown sound for acceptability in a particular system.

Discharge Check Valve

A low mass, disk-type check valve in the discharge fitting of the compressor prevents the high side, high pressure discharge gas from flowing rapidly back through the compressor after shutdown.

Motor Overload Protection

Conventional internal line break motor overload protection is provided. The overload protector opens the common connection of a single-phase motor and the center of the Y connection on three-phase motors. The three-phase overload protector provides primary single-phase protection. Both types of overload protectors react to current and motor winding temperature.

Operating Envelope

The ZP*K6 compressor family is approved for use with R-410A only. See **Figure 1** for the R-410A operating envelope. The envelope represents acceptable operating conditions with 20F° (11K) superheat in the return gas.

Power Supply

All motors for the ZP compressors, whether single or three phase, with the exception of the “PFV” 208-230, 1Ø, 60 Hz motor, are designed to operate within a voltage range of +/-10% of the voltages shown on the nameplate. For example, a compressor with a nameplate voltage of 200-230 volts can start and operate within a range of 180-253 volts. Compressors with a “PFV” designated motor such as ZP24K6E-PFV, may only be operated in a range of 197-253 volts under maximum load conditions.

Accumulators

The use of accumulators is very dependent on the application. The Copeland Scroll compressor's inherent ability to handle liquid refrigerant during occasional operating flood back situations make the use of an accumulator unnecessary in standard designs such as condensing units. Applications such as heat pumps with orifice refrigerant control that allow large volumes of liquid refrigerant to flood back to the compressor during normal steady operation can dilute the oil to such an extent that bearings are inadequately lubricated, and wear will occur. In such a case an accumulator must be used to reduce flood back to a safe level that the compressor can handle. Heat pumps designed with a TXV to control refrigerant during heating may not require an accumulator if testing assures the system designer that there will be no flood back throughout the operating range. To test for flood back conditions and determine if the accumulator or TXV design is adequate, please see the section entitled **Application Tests**. The accumulator oil return orifice should be from .040 to .055 inches (1 - 1.4mm) in diameter depending on compressor size and compressor flood back results. A large-area protective screen no finer than 30x30 mesh (0.6mm openings) is required to protect this small orifice from plugging. Tests have shown that a small screen with a fine mesh can easily become plugged causing oil starvation to the compressor bearings. The size of the accumulator depends upon the operating range of the system and the amount of sub cooling and subsequent head pressure allowed by the refrigerant

control. System modeling indicates that heat pumps that operate down to and below 0°F (-18°C) will require an accumulator that can hold around 70% to 75% of the system charge. Behavior of the accumulator and its ability to prevent liquid slugging and subsequent oil pump-out at the beginning and end of the defrost cycle should be assessed during system development. This will require special accumulators and compressors with sight tubes and/or sight glasses for monitoring refrigerant and oil levels.

Screens

Screens finer than 30x30 mesh (0.6mm openings) should not be used anywhere in the system with these compressors. Field experience has shown that finer mesh screens used to protect thermal expansion valves, capillary tubes, or accumulators can become temporarily or permanently plugged with normal system debris and block the flow of either oil or refrigerant to the compressor. Such blockage can result in compressor failure.

Crankcase Heat - Single Phase

Crankcase heater recommendations/requirements for single phase compressors are as follows:

A heater is recommended if:

compressor charge limit < **system charge** < system charge limit

A heater is required if:

compressor charge limit < **system charge** > system charge limit

Please refer to **Table 4** for a complete listing of compressor and system charge limit values.

Experience has shown that compressors may fill with liquid refrigerant under certain circumstances and system configurations, notably after long off cycles when the compressor has cooled. This may cause excessive start-up clearing noise; or the compressor may start and trip the internal overload protector several times before running. The addition of a crankcase heater will reduce customer noise and dimming light complaints since the compressor will no longer have to clear out liquid during starting. **Table 5** lists the crankcase heaters recommended for the various models and voltages. **WARNING! Crankcase heaters must be properly grounded.** To properly install the crankcase heater, the heater should be installed as low on the compressor shell as possible, either above or below the lower bearing pin welds that protrude from the compressor shell. Ideally the heater would come

together for clamping with the vertical shell seam weld coming up through the area where the crankcase heater is clamped together. See **Figure 5** for details. Tighten the clamp screw carefully ensuring that the heater is uniformly tensioned along its entire length and that the circumference of the heater element is in complete contact with the compressor shell. It's important that the clamp screw is torqued to the range of 20-25 in-lb (2.3-8 N m) to ensure adequate contact and to prevent heater burnout. Never apply power to heater in free air or before heater is installed on compressor to prevent overheating and burnout.

Crankcase Heat - Three Phase

A crankcase heater is required for three-phase compressors when the system charge exceeds the compressor charge limit listed in **Table 4**.

Minimum Run Time

There is no set answer to how often scroll compressors can be started and stopped in an hour, since it is highly dependent on system configuration. Other than the considerations in the section on Brief Power Interruptions, there is no minimum off time because Copeland Scroll compressors start unloaded, even if the system has unbalanced pressures. The most critical consideration is the minimum run time required to return oil to the compressor after startup. To establish the minimum run time, obtain a sample compressor equipped with a sight tube (available from Emerson) and install it in a system with the longest connecting lines that are approved for the system. The minimum on time becomes the time required for oil lost during compressor startup to return to the compressor sump and restore a minimal oil level that will assure oil pick up through the crankshaft. Cycling the compressor for a shorter period than this, for instance to maintain very tight temperature control, will result in progressive loss of oil and damage to the compressor. See **AE17-1262** for more information on preventing compressor short cycling.

Reversing Valves

NOTICE

Reversing valve sizing must be within the guidelines of the valve manufacturer. Required pressure drop to ensure valve shifting must be measured throughout the operating range of the unit and compared to the valve manufacturer's data. Low ambient heating conditions with low

flow rates and low pressure drop across the valve can result in a valve not shifting. This can result in a condition where the compressor appears to be not pumping (i.e. balanced pressures). It can also result in elevated compressor sound levels.

ZP*K6 compressors are equipped with the transient sound solution feature that allows the compressor to run throughout the defrost cycle transition with low running sound. It is not necessary to de-energize the ZP*K6 compressor when entering and exiting the defrost cycle.

The reversing valve solenoid should be wired so that the valve does not reverse when the system is shut off by the operating thermostat in the heating or cooling mode. If the valve is allowed to reverse at system shutoff, suction and discharge pressures are reversed to the compressor. This results in pressures equalizing through the compressor which can cause the compressor to slowly rotate backwards until the pressures equalize. This condition does not affect compressor durability but can cause unexpected sound after the compressor is turned off.

Low Ambient Cut-Out

A low ambient cut-out is not required to limit air-to air heat pump operation. Air-to-water heat pumps must be reviewed since this configuration could possibly run outside of the approved operating envelope (**Figure 1**) causing overheating or excessive wear.

Oil Type

Polyol ester (POE) oil is used in ZP*K6E compressors. See the compressor nameplate for the original oil charge. A complete recharge should be approximately four fluid ounces (118 ml) less than the nameplate value. If additional oil is needed in the field, Copeland™ Ultra 32-3MAF, Lubrizol Emkarate RL32-3MAF, Parker Emkarate RL32-3MAF/(Virginia) LE32-3MAF, or Nu Calgon 4314-66 (Emkarate RL32-3MAF) should be used. Copeland™ Ultra22 CC, Hatcol EAL22CC, and Mobil EAL Arctic 22 CC are acceptable alternatives.

⚠ WARNING

POE may cause an allergic skin reaction and must be handled carefully and the proper protective equipment (gloves, eye protection, etc.) must be used when handling POE lubricant. POE must not come into contact with any surface or material that might be harmed by POE, including without limitation, certain polymers (e.g. PVC/ CPVC and polycarbonate). Refer to the Safety Data Sheet (SDS) for further details.

Contaminant Control

Copeland Scroll compressors leave the factory with a miniscule amount of contaminants. Manufacturing processes have been designed to minimize the introduction of solid or liquid contaminants. Dehydration and purge processes ensure minimal moisture levels in the compressor and continuous auditing of lubricant moisture levels ensure that moisture isn't inadvertently introduced into the compressor.

It is generally accepted that system moisture levels should be maintained below 50 ppm. **A filter-drier is required on all R-410A and POE lubricant systems to prevent solid particulate contamination, oil dielectric strength degradation, ice formation, oil hydrolysis, and metal corrosion.** It is the system designer's responsibility to make sure the filter-drier is adequately sized to accommodate the contaminants from system manufacturing processes that leave solid or liquid contaminants in the evaporator coil, condenser coil, and interconnecting tubing plus any contaminants introduced during the field installation process. Molecular sieve and activated alumina are two filter-drier materials designed to remove moisture and mitigate acid formation. A 100% molecular sieve filter can be used for maximum moisture capacity. A more conservative mix, such as 75% molecular sieve and 25% activated alumina, should be used for service applications.

Long Line Sets/High Refrigerant Charge

Some system configurations may contain higher-than-normal refrigerant charges either because of large internal coil volumes or long line sets. If such a system also contains an accumulator then the permanent loss of oil from the compressor may become critical. If the system contains more than 20 pounds (9 kg) of refrigerant, it is our recommendation to add one fluid ounce of oil for every 5 pounds (15 ml/kg) of refrigerant over this amount. If the system contains an accumulator the manufacturer of the accumulator should be consulted for a pre-charge recommendation.

Other system components such as shell and tube evaporators can trap significant quantities of oil and should be considered in overall oil requirements. Reheat coils and circuits that are inactive during part of the normal cycle can trap significant quantities of oil if system piping allows the oil to fall out of the refrigerant flow into an inactive circuit. The oil level must be carefully monitored during system development, and

corrective action should be taken if compressor oil level falls below the top of the lower bearing bracket for more than two minutes. The lower bearing bracket weld points on the compressor shell can be used as a low-oil-level marker.

Discharge Mufflers

Flow through Copeland Scroll compressors is semi-continuous with relatively low pulsation. External mufflers, where they are normally applied to piston compressors today, may not be required for Copeland Scroll compressors. Because of variability between systems, however, individual system tests should be performed to verify acceptability of sound performance. When no testing is performed, mufflers are recommended in heat pumps. A hollow shell muffler such as the Emerson Flow Controls APD-1 or APD-054 will work quite well. The mufflers should be located a minimum of six inches (15 cm) to a maximum of 18 inches (46 cm) from the compressor for most effective operation. The farther the muffler is placed from the compressor within these ranges the more effective it may be. If adequate attenuation is not achieved, use a muffler with a larger cross-sectional area to inlet-area ratio. The ratio should be a minimum of 20:1 with a 30:1 ratio recommended. The muffler should be from four to six inches (10 -15 cm) long.

Air Conditioning System Suction Line Noise and Vibration

Copeland Scroll compressors inherently have low sound and vibration characteristics. However, the sound and vibration characteristics differ in some respects from those of reciprocating compressors. In rare instances, these could result in unexpected sound complaints.

The scroll compressor makes both a rocking and torsional motion, and enough flexibility must be provided in the line to prevent vibration transmission into any lines attached to the unit. In a split system the most important goal is to ensure minimal vibration is all directions at the service valve to avoid transmitting vibrations to the structure to which the lines are fastened. **Table 3** lists design configurations for tubing configuration and base valve mounting.

The sound phenomena described above are not usually associated with heat pump systems because of the isolation and attenuation provided by the reversing valve and tubing bends.

Mounting Parts

ZP09-31K6 compressor have pierced mounting holes. ZP34-54K6 compressors have extruded mounting holes, so the grommet must have a relief cut into its main body to accommodate the down turned lip of the hole. **Table 5** lists the mounting parts kits to be used with these compressors. Many OEM customers buy the mounting parts directly from the supplier, but Emerson's grommet design and durometer recommendation should be followed for best vibration reduction through the mounting feet.

Single Phase Starting Characteristics

Start assist devices are usually not required, even if a system utilizes non-bleed expansion valves. Due to the inherent design of the Copeland Scroll compressor, the internal compression components always start unloaded even if system pressures are not balanced. In addition, since internal compressor pressures are always balanced at startup, low voltage starting characteristics are excellent for Copeland Scroll compressors. The starting **Locked Rotor Amperage (LRA)**, also referred to as **inrush current**, is normally six or more times higher than the rated running amperage of the compressor and lasts from 100 to 300 milliseconds until the rotor starts turning. This high starting current may result in significant "sag" in voltage where a poor power supply is encountered. Low starting voltage reduces the starting torque of the compressor and subsequently increases the time the compressor is in a locked rotor condition. This could cause light dimming. Start components will substantially reduce start time and consequently the magnitude and duration of both light dimming and conduit buzzing. Specified starting components can be found in the Online Product Information section of www.emersonclimate.com.

PTC Start Components

For less severe voltage drops or as a start boost, solid state Positive Temperature Coefficient (PTC) devices rated from 10 to 25 ohms may be used to facilitate starting for any of these compressors.

SecureStart™ is marketed and sold by Emerson Climate Technologies, Inc. to reduce inrush current by up to 75% on single phase Copeland Scroll compressors. SecureStart significantly reduces inrush and associated light dimming, while offering a number of other protective benefits. For more information on SecureStart, please refer to **AE8-1370**.

Electrical Connections



Molded electrical plug (Emerson p/n 529-0060-04 or OEM equivalent) must be used in all applications.

The orientation of the electrical connections on the Copeland Scroll compressors is shown in **Figure 4**. The molded electrical plug must be installed by hand or with a dedicated, pneumatic installation tool. The use of a hammer or other blunt instrument to install the plug is strictly forbidden.

Deep Vacuum Operation

Copeland Scroll compressors incorporate internal low vacuum protection and will stop pumping (unload) when the pressure ratio exceeds approximately 10:1. There is an audible increase in sound when the scrolls start unloading.

CAUTION Copeland Scroll compressors (as with any refrigerant compressor) should never be used to evacuate a refrigeration or air conditioning system. The scroll compressor can be used to pump down refrigerant in a unit as long as the pressures remain within the operating envelope shown in **Figure 1**. Prolonged operation at low suction pressures will result in overheating of the scrolls and permanent damage to the scroll tips, drive bearing and internal seal. See **AE24-1105** for proper system evacuation procedures.

Suction and Discharge Fittings

Copeland Scroll compressors have copper plated steel suction and discharge fittings. These fittings are far more rugged and less prone to leaks than copper fittings used on other compressors. Due to the different thermal properties of steel and copper, brazing procedures may have to be changed from those commonly used. See **Figure 6** for assembly line and field brazing recommendations.

System Tubing Stress

System tubing should be designed to keep tubing stresses below 9.5 ksi (62 MPa), the endurance limit of copper tubing. Start, stop and running (resonance) cases should be evaluated.

Three Phase Scroll Compressor Electrical Phasing

Copeland Scroll compressors, like several other types of compressors, will only compress gas in one rotational direction. Direction of rotation is not an issue with single phase compressors since they will always start and run in the proper direction (except as described in the section “Brief Power Interruptions”). Three phase compressors will rotate in either direction depending upon phasing of the power. Since there is a 50% chance of connecting power in such a way as to cause rotation in the reverse direction, **it is important to include notices and instructions in appropriate locations on the equipment to ensure that proper rotation direction is achieved when the system is installed and operated.**

Verification of proper rotation direction is made by observing that suction pressure drops and discharge pressure rises when the compressor is energized. Reverse rotation will result in no pressure differential as compared to normal values. A compressor running in reverse will sometimes make an abnormal sound.

There is no negative impact on durability caused by operating three phase Copeland Scroll compressors in the reversed direction for a short period of time (under one hour). After several minutes of reverse operation, the compressor’s internal overload protector will trip shutting off the compressor. If allowed to repeatedly restart and run in reverse without correcting the situation, the compressor bearings will be permanently damaged because of oil loss to the system.

Brief Power Interruptions

Brief power interruptions (less than ½ second) may result in powered reverse rotation of single-phase Copeland Scroll compressors. This occurs because high-pressure discharge gas expands backward through the scrolls during interruption, causing the scroll to orbit in the reverse direction. When power is reapplied while reverse rotation is occurring, the compressor may continue to run in the reverse direction for some time before the compressor’s internal overload trips. This will not cause any damage to the compressor, and when the internal overload resets, the compressor will start and run normally.

To avoid disruption of operation, an electronic control that can sense brief power interruptions may be used to lock out the compressor for a short time. This control could be incorporated in other system controls (such as defrost control board or the system thermostat), or can be a stand-alone control. Functional specifications

for this control as well as a suggested wiring diagram are shown in **Figure 3**. No time delay is necessary for three phase models since the motor starting torque is high enough to overcome reverse rotation.

A start kit (specified start capacitor and relay) is another effective means of mitigating a powered reverse condition that is caused by a brief power interruption. In addition, SecureStart has the ability to detect when the compressor is running backwards. When running backwards is detected by SecureStart, it will de-energize the compressor and restart it after three minutes.

Tandem Compressors

At this time, ZPK*6 compressors have not been qualified for tandem applications.

Maximum Tilt Angle

OEMs and end-users often ask about the maximum allowable tilt angle of the compressor. Some applications, such as transportation air-conditioning or mobile radar applications, may require the compressor to operate at some angle from vertical. Or, service personnel may be required to maneuver a unit through a stairwell or other cramped area that might require tilting the unit. The maximum allowable tilt angles from horizontal are summarized below:

- Max Tilt Angle With Compressor Running = 15°**
- Max Tilt Angle With Compressor Not Running = 60°**

APPLICATION TESTS

Application Test Summary

There are a minimal number of tests the system designer will want to run to ensure the system operates as designed. These tests should be performed during system development and are dependent on the system type and amount of refrigerant charge. These application tests are to help identify gross errors in system design that may produce conditions that could lead to compressor failure. The Continuous Floodback Test and Field Application Test, both outlined below, are two tests to run to help verify the design. When to run these tests can be summarized as follows:

Continuous Floodback:

Required on all heatpumps.

Field Application Test:

Required for any unit where both the design system

charge is higher than the compressor refrigerant charge limit listed in **Table 4**; and a capillary tube, fixed orifice, or bleed-type TXV is used on either the indoor or the outdoor coil of the unit.

Continuous Floodback Test

It is expected that the design would not flood during standard air conditioning operation. Running a partially blocked indoor air filter or loss of evaporator air flow test and comparing the sump temperature results to **Figure 2** is recommended. The use of a TXV in heating does not guarantee operation without flood back in the lower end of the unit/TXV operating range.

To test for excessive continuous liquid refrigerant flood back, it is necessary to operate the system in a test room at conditions where steady state flood back may occur (low ambient heating operation). Thermocouples should be attached with glue or solder to the center of the bottom shell and to the suction and discharge lines approximately 6 inches (15 cm) from the shell. These thermocouples should be insulated from the ambient air with Permagum® or other thermal insulation to be able to record true shell and line temperatures. If the system is designed to be field charged, it should be overcharged by 15% in this test to simulate overcharging often found in field installations.

The system should be operated at an indoor temperature of 70°F (21°C) and outdoor temperature extremes of 10°F (-12°C) or lower in heating to produce flood back conditions. The compressor suction and discharge pressures and temperatures as well as the sump temperature should be recorded. The system should be allowed to frost up for several hours (disabling the defrost control and spraying water on the outdoor coil may be necessary) to cause the saturated suction temperature to fall below 0°F (-18°C). The compressor sump temperature must remain above the sump temperature shown in **Figure 2** or design changes must be made to reduce the amount of flood back. If an accumulator is used, this test can be used to test the effectiveness of the accumulator. Increasing indoor coil volume, increasing outdoor air flow, reducing refrigerant charge, decreasing capillary or orifice diameter, and adding a charge compensator can also be used to reduce excessive continuous liquid refrigerant flood back.

Field Application Test

To test for repeated, excessive liquid flood back

during normal system off-cycles, perform the **Field Application Test** that is outlined in **Table 2**. Obtain a sample compressor with a sight-tube to measure the liquid level in the compressor when it is off.

Note: The sight-tube is not a good liquid level indicator when the compressor is running because the top of the sight-tube is at a lower pressure than the bottom causing a higher apparent oil level.

Set the system up in a configuration with the indoor unit elevated several feet above the outdoor unit with a minimum of 25 feet (8 meters) of connecting tubing with no traps between the indoor and outdoor units. If the system is designed to be field charged, the system should be overcharged by 15% in this test to simulate field overcharging. Operate the system in the cooling mode at the outdoor ambient, on/off cycle times, and number of cycles specified in **Table 2**. Record the height of the liquid in the compressor at the start of each on cycle, any compressor overload trips, or any compressor abnormal starting sounds during each test. Review the results with Application Engineering to determine if an accumulator or other means of off cycle migration control are required. **This test does not eliminate the requirement for a crankcase heater if the system charge level exceeds the values in Table 4.** The criteria for pass/fail is whether the liquid level reaches the level of the compressor suction tube connection. Liquid levels higher than this can allow refrigerant/oil to be ingested by the scrolls and pumped out of the compressor after start-up.

The tests outlined above are for common applications of compressors in this family. Many other applications of the compressor exist, and tests to insure those designs can't possibly be covered in this bulletin. Please consult with Application Engineering on applications outside of those outlined above for the appropriate application tests.

ASSEMBLY LINE PROCEDURES

Installing the Compressor



Use care and the appropriate material handling equipment when lifting and moving compressors. Personal safety equipment must be used.

Copeland Scroll compressors leave the factory dehydrated and with a positive dry air charge. Plugs should not be removed from the compressor until the compressor has had sufficient time to warm up if stored outside and is ready for assembly in the unit. The suggested warm up time is one hour per 4°F (2K) difference between outdoor and indoor temperature. It is suggested that the larger suction plug be removed first to relieve the internal pressure. Removing the smaller discharge plug could result in a spray of oil out of this fitting since some oil accumulates in the head of the compressor after Emerson's run test. The inside of both fittings should be wiped with a lint free cloth to remove residual oil prior to brazing. A compressor containing POE oil should never be left open longer than 5 minutes.

Suction Funnel

The ZPK6 compressor includes a suction funnel which is bolted onto the fixed scroll internally. The funnel can be seen by looking through the suction tube from the outside of the compressor. Please see **Figure 8** for pictorial views.

It is important that nothing is inserted into the suction tube further than the normal depth of the unit suction tube assembly.

Assembly Line Brazing Procedure



Personal safety equipment must be used during brazing operation. Heat shields should be used to prevent overheating or burning nearby temperature sensitive parts. Fire extinguishing equipment should be accessible in the event of a fire.

Figure 6 discusses the proper procedures for brazing the suction and discharge lines to a scroll compressor. **NOTICE** It is important to flow nitrogen through the system while brazing all joints during the system assembly process. Nitrogen displaces the air and prevents the formation of copper oxides in the system. If allowed to form, the copper oxide flakes can later be swept through the system and block screens such as those protecting capillary tubes, thermal expansion valves, and accumulator oil return holes. Any blockage of oil or refrigerant may damage the compressor resulting in failure.

Pressure Testing



Never pressurize the compressor to more than 475 psig (32.8 bar) for leak checking purposes. Never pressurize the compressor from a nitrogen cylinder or other pressure source without an appropriately sized pressure regulating and relief valve.

The pressure used on the line to meet the UL burst pressure requirement must not be higher than 475 psig (33 Bar). Higher pressure may result in permanent deformation of the compressor shell and possible misalignment or bottom cover distortion.

Assembly Line System Charging Procedure

Systems should be charged with liquid on the high side to the extent possible. The majority of the charge should be pumped in the high side of the system to prevent low voltage starting difficulties, hipot failures, and bearing washout during the first-time start on the assembly line. If additional charge is needed, it should be added as liquid to the low side of the system with the compressor operating. Pre-charging on the high side and adding liquid on the low side of the system are both meant to protect the compressor from operating with abnormally low suction pressures during charging.

NOTICE Do not operate the compressor without enough system charge to maintain at least 55 psig (3.8 bar) suction pressure. Do not operate the compressor with the low pressure cut-out disabled. Do not operate with a restricted suction or liquid line. Depending on the discharge pressure, allowing pressure to drop below 55 psig (3.8 bar) for more than a few seconds may overheat the scrolls and cause early drive bearing damage. **NOTICE** Do not use the compressor to test the opening set point of a high pressure cutout. Bearings are susceptible to damage before they have had several hours of normal operation for proper break in.

"Hipot" (AC High Potential) Testing



Use caution with high voltage and never hipot when compressor is in a vacuum.

Copeland Scroll compressors are configured with the motor down and the pumping components at the top

of the shell. As a result, the motor can be immersed in refrigerant to a greater extent than hermetic reciprocating compressors when liquid refrigerant is present in the shell. In this respect, the scroll is more like semi-hermetic compressors that have horizontal motors partially submerged in oil and refrigerant. When Copeland Scroll compressors are hipot tested with liquid refrigerant in the shell, they can show higher levels of leakage current than compressors with the motor on top. This phenomenon can occur with any compressor when the motor is immersed in refrigerant. The level of current leakage does not present any safety issue. To lower the current leakage reading, the system should be operated for a brief period of time to redistribute the refrigerant to a more normal configuration and the system hipot tested again. See **AE4-1294** for megohm testing recommendations. **Under no circumstances should the hipot test be performed while the compressor is under a vacuum.**

Final Run Test

Customers that use a nitrogen final run test must be careful to not overheat the compressor. Nitrogen is not a good medium for removing heat from the compressor, and the scroll tips can be easily damaged with high compression ratios and/or long test times. Copeland Scroll compressors are designed for use with refrigerant, and testing with nitrogen may result in a situation where the compressor does not develop a pressure differential (no pump condition). When testing with nitrogen, the compressor must be allowed to cool for several minutes between tests.

Single phase scrolls with an electrical nomenclature of "PFV" (208-230 volt, 1Ø, 60 Hertz) at the end of the model number are guaranteed to start at 187 volts or higher and must have a voltage no lower than 197 volts once the compressor is running under load. All other compressor voltages, both single and three phase, 50 & 60 Hertz are guaranteed to start and run at 10% below the lowest voltage shown on the nameplate.

Variable transformers used on assembly lines are often incapable of maintaining the starting voltage when larger compressors are tested. To test for voltage sag during starting, the first compressor in a production run should be used to preset the voltage. Remove the start wire from the compressor and apply 200 volts to the compressor. With the start winding removed, the compressor will remain on locked rotor long enough to read the supply voltage. If the voltage sags below

the minimum guaranteed starting voltage, the variable transformer must be reset to a higher voltage. When discussing this starting amperage it should be noted that "inrush current" and locked rotor amps (LRA) are one and the same. The nameplate LRA is determined by physically locking a compressor and applying the highest nameplate voltage to the motor. The amperage that the motor draws after four seconds is the value that is used on the nameplate. Since there is a direct ratio between voltage and locked rotor amperage, the lower the line voltage used to start the compressor, the lower the locked rotor amperage will be.

Unbrazing System Components



Before attempting to unbraid, it is important to recover all refrigerant from both the high and low side of the system.

If the refrigerant charge is removed from a scroll-equipped unit by recovering one side only, it is very possible that either the high or low side of the system remains pressurized. If a brazing torch is then used to disconnect tubing, the pressurized refrigerant and oil mixture could ignite when it escapes and contacts the brazing flame. Instructions should be provided in appropriate product literature and assembly (line repair) areas. If compressor removal is required, the compressor should be cut out of the system rather than unbrazed.

SERVICE PROCEDURES

Copeland Scroll Compressor Functional Check

A functional compressor test during which the suction service valve is closed to check how low the compressor will pull the suction pressure is not a good indication of how well a compressor is performing. **Such a test will damage a scroll compressor in a few seconds.**

The following diagnostic procedure should be used to evaluate whether a Copeland Scroll compressor is functioning properly:

1. Proper voltage to the unit should be verified.
2. Determine if the internal motor overload has opened or if an internal motor short or ground fault has developed. If the internal overload has opened, the compressor must be allowed to cool sufficiently to allow it to reset.

3. Check that the compressor is correctly wired.
4. Proper indoor and outdoor blower/fan operation should be verified.
5. With service gauges connected to suction and discharge pressure fittings, turn on the compressor. If suction pressure falls below normal levels the system is either low on charge or there is a flow blockage in the system.
6. **Single phase compressors** - If the compressor starts and the suction pressure does not drop and discharge pressure does not rise to normal levels, either the reversing valve (if so equipped) or the compressor is faulty. Use normal diagnostic procedures to check operation of the reversing valve. **Three phase compressors** - If suction pressure does not drop and discharge pressure does not rise to normal levels, reverse any two of the compressor power leads and reapply power to make sure the compressor was not wired to run in reverse. If pressures still do not move to normal values, either the reversing valve (if so equipped) or the compressor is faulty. Reconnect the compressor leads as originally configured and use normal diagnostic procedures to check operation of the reversing valve.
7. To test if the compressor is pumping properly, the compressor current draw must be compared to published compressor performance curves using the operating pressures and voltage of the system. If the measured average current deviates more than +/-20% from published values, a faulty compressor may be indicated. A current imbalance exceeding 20% of the average on the three phases of a three-phase compressor should be investigated further. A more comprehensive trouble-shooting sequence for compressors and systems can be found in Section H of the **Emerson Climate Technologies Electrical Handbook, Form No. 6400**.
8. Note that the ZP10-31K6 three-phase motors use a modified "Scott-T" connection and don't have equal resistances on all three windings. Two windings will have equal resistances and the third winding will be up to 30% different from the other two. Carefully compare measured motor resistance values to the two different published resistance values for a given compressor model before replacing the compressor as being defective. The larger ZP34-54K6 compressors

have conventional three-phase motors with equal resistances in each winding.

9. Before replacing or returning a compressor, be certain that the compressor is actually faulty. As a minimum, recheck compressors returned from the field in the shop or depot by testing for a grounded, open or shorted winding and the ability to start. The orange tag in the service compressor box should be filled out and attached to the failed compressor to be returned. The information on this tag is captured in our warranty data base.

Compressor Replacement After a Motor Burn

In the case of a motor burn, the majority of contaminated oil will be removed with the compressor. The rest of the oil is cleaned with the use of suction and liquid line filter driers. A 100% activated alumina suction filter drier is recommended but must be removed after 72 hours. See **AE24-1105** for clean up procedures and **AE11-1297** for liquid line filter-drier recommendations. **NOTICE It is highly recommended that the suction accumulator be replaced if the system contains one.** This is because the accumulator oil return orifice or screen may be plugged with debris or may become plugged shortly after a compressor failure. This will result in starvation of oil to the replacement compressor and a second failure. The system contactor should be inspected for pitted/burnt contacts and replaced if necessary. It is highly recommended that the run capacitor be replaced when a single phase compressor is replaced.

Start-Up of a New or Replacement Compressor

It is good service practice, when charging a system with a scroll compressor, to charge liquid refrigerant into the high side only. It is not good practice to dump liquid refrigerant from a refrigerant cylinder into the crankcase of a stationary compressor. If additional charge is required, charge liquid into the low side of the system with the compressor operating. **CAUTION Do not start the compressor while the system is in a deep vacuum.** Internal arcing may occur when any type of compressor is started in a vacuum. **NOTICE Do not operate the compressor without enough system charge to maintain at least 55 psig (3.8 bar) suction pressure. Do not operate with a restricted suction or liquid line. Do not operate with the low pressure cut-out disabled.** Allowing suction pressure to drop below 55 psig (3.8 bar) for more than a few seconds may overheat the scrolls and cause early drive bearing damage. Never install a system in the field and leave

it unattended with no charge, a holding charge, or with the service valves closed without securely locking out the system. This will prevent unauthorized personnel from accidentally ruining the compressor by operating with no refrigerant flow.

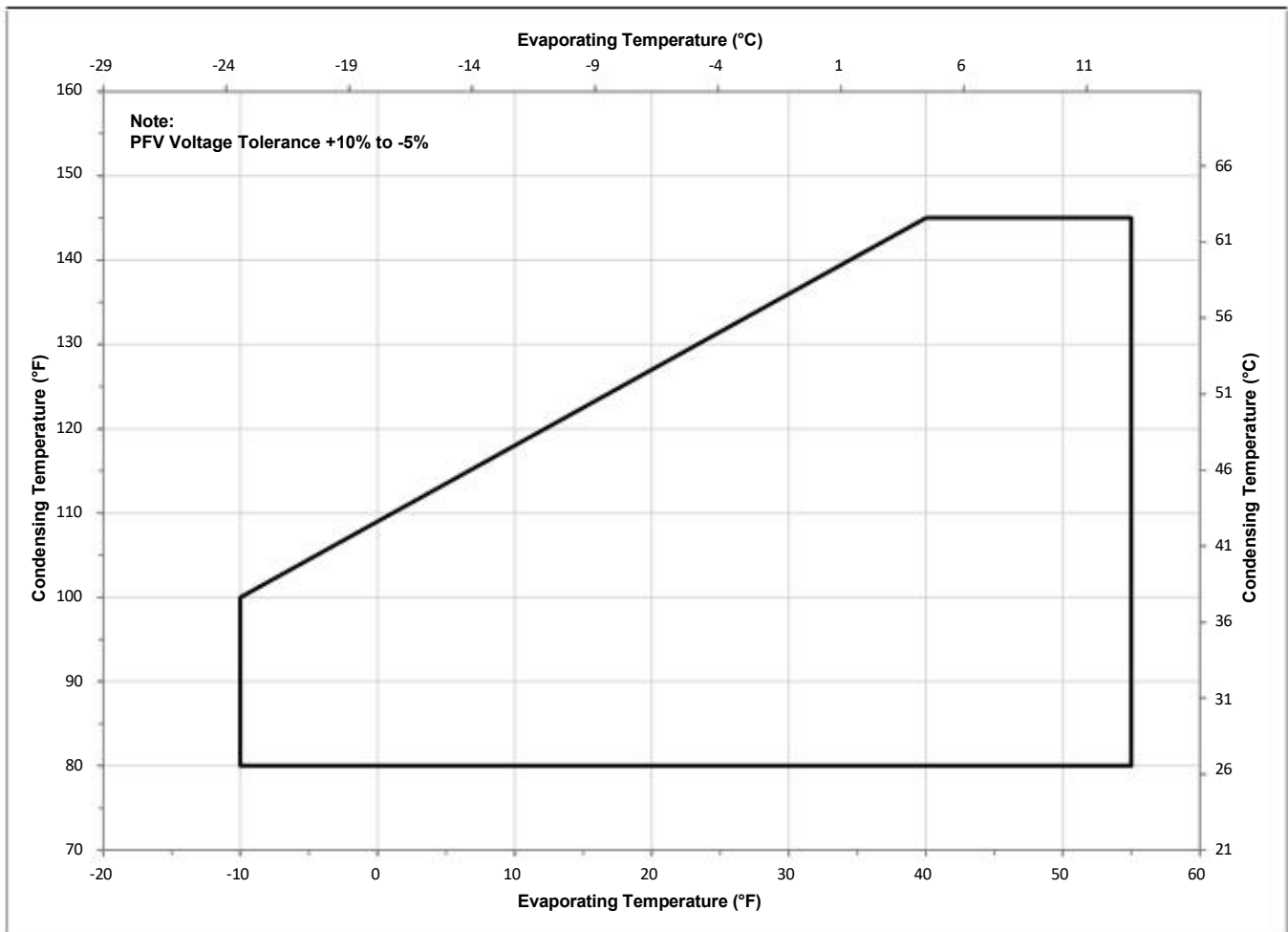
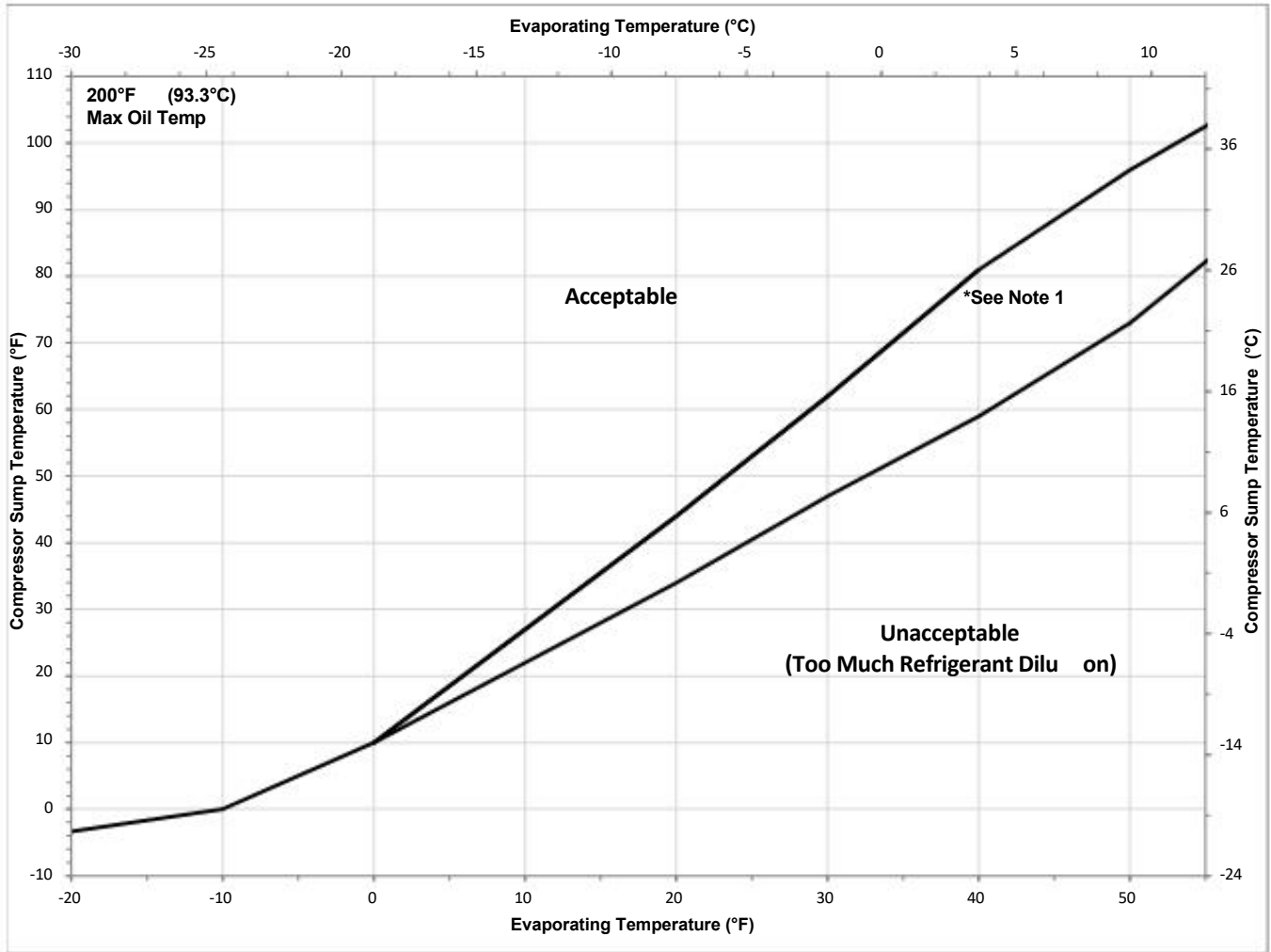
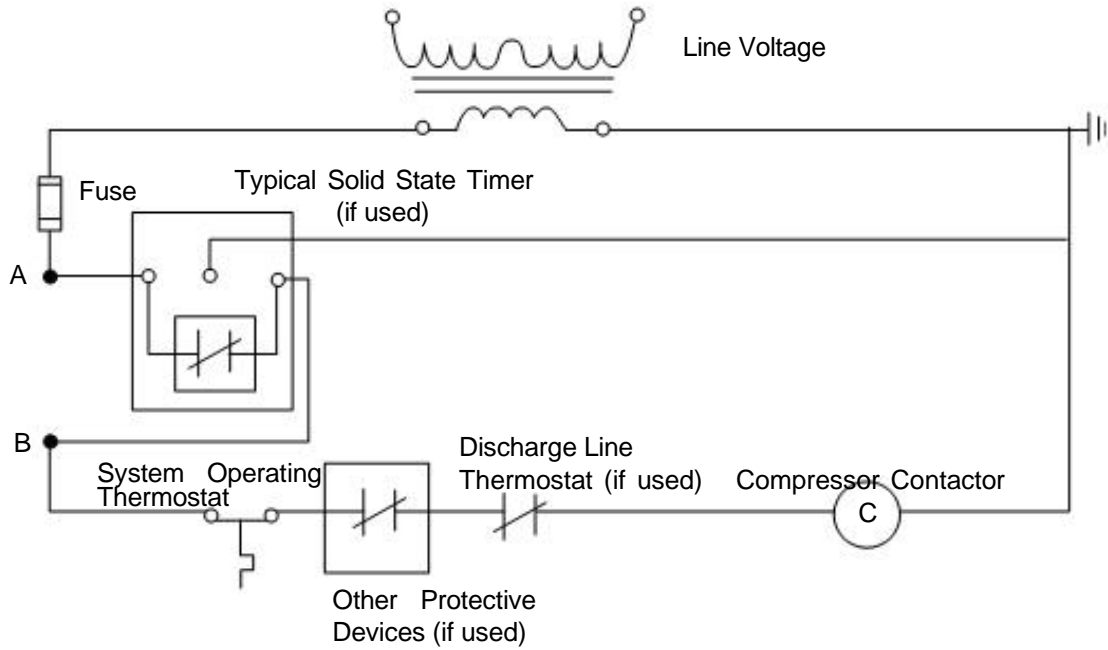

Figure 1
R-410A Scroll Operating Envelope



Note 1: Operation in this refrigerant dilution area is safe in air-to-air heat pump heating mode. For other applications, such as AC only, review expansion device to raise superheat. A cold sump may result in high refrigerant migration after shut down.

Figure 2
Oil Dilution Chart



Time Delay Relay Specifications

Timer Opens: 1 Electrical Cycle
(.016 Sec. With 60 HZ Operation)
after power is removed

Timer Closes: Greater than 5 seconds later, whether
power is restored or not

Figure 3
Time Delay Wiring

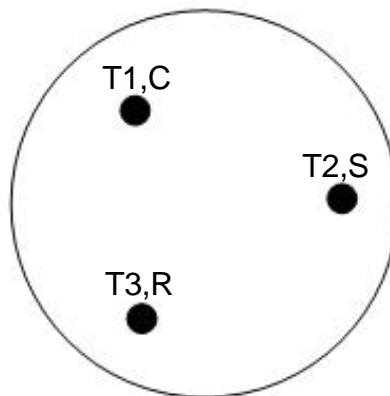

Figure 4
Compressor Electrical Connection

Connect the heater so that the connection point straddles the compressor seam weld

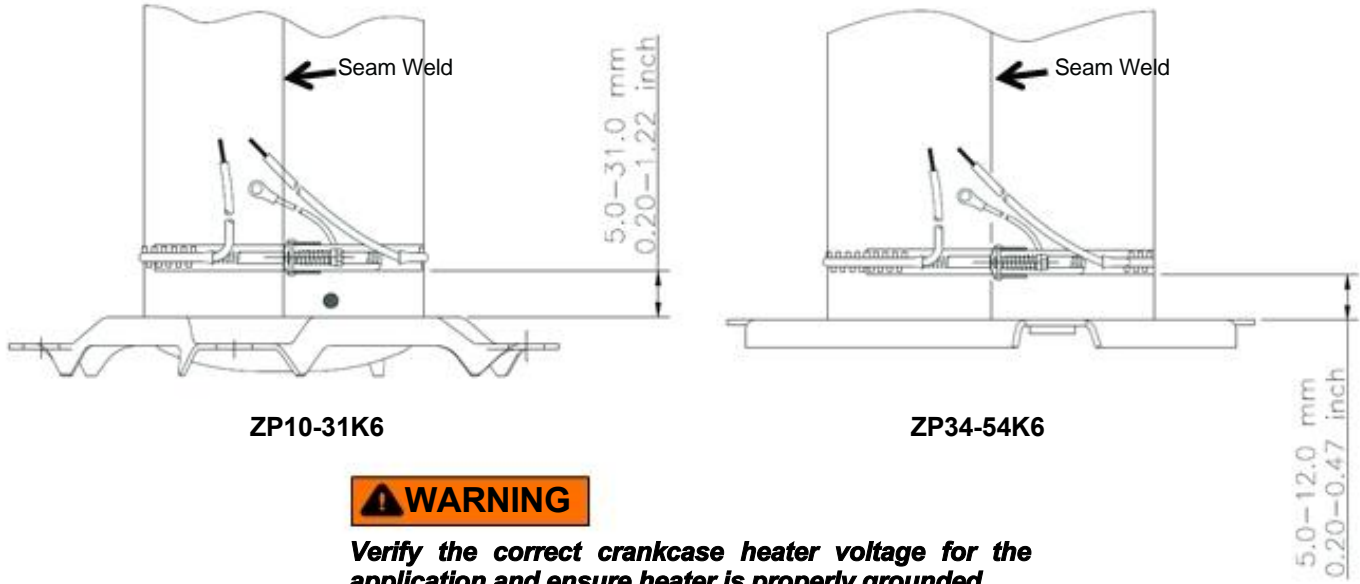

Figure 5
Crankcase Heater

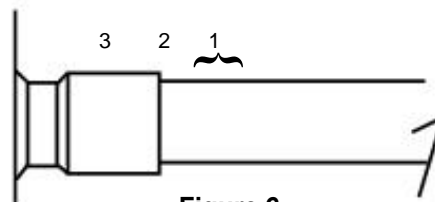

Figure 6
Scroll Suction Tube Brazing

New Installations

- The copper-coated steel suction tube on scroll compressors can be brazed in approximately the same manner as any copper tube.
- Recommended brazing materials: Any silfos material is recommended, preferably with a minimum of 5% silver. However, 0% silver is acceptable.
- Be sure suction tube fitting I.D. and suction tube O.D. are clean prior to assembly. If oil film is present wipe with denatured alcohol, Dichloro-Trifluoroethane or other suitable solvent.
- Using a double-tipped torch apply heat in Area 1. As tube approaches brazing temperature, move torch flame to Area 2.
- Heat Area 2 until braze temperature is attained, moving torch up and down and rotating around tube as necessary to heat tube evenly. Add braze material to the joint while moving torch around joint to flow braze material around circumference.
- After braze material flows around joint, move torch to heat Area 3. This will draw the braze material down into the joint. The time spent heating Area 3 should be minimal.
- As with any brazed joint, overheating may be detrimental to the final result.

Field Service



Remove refrigerant charge from both the low and high side of the compressor before cutting the suction and discharge lines to remove the compressor. Verify the charge has been completely removed with manifold gauges.

- To disconnect: Reclaim refrigerant from both the high and low side of the system. Cut tubing near compressor.
- To reconnect:
 - Recommended brazing materials: Silfos with minimum 5% silver or silver braze material with flux.
 - Insert tubing stubs into fitting and connect to the system with tubing connectors.
 - Follow **New Installation** brazing

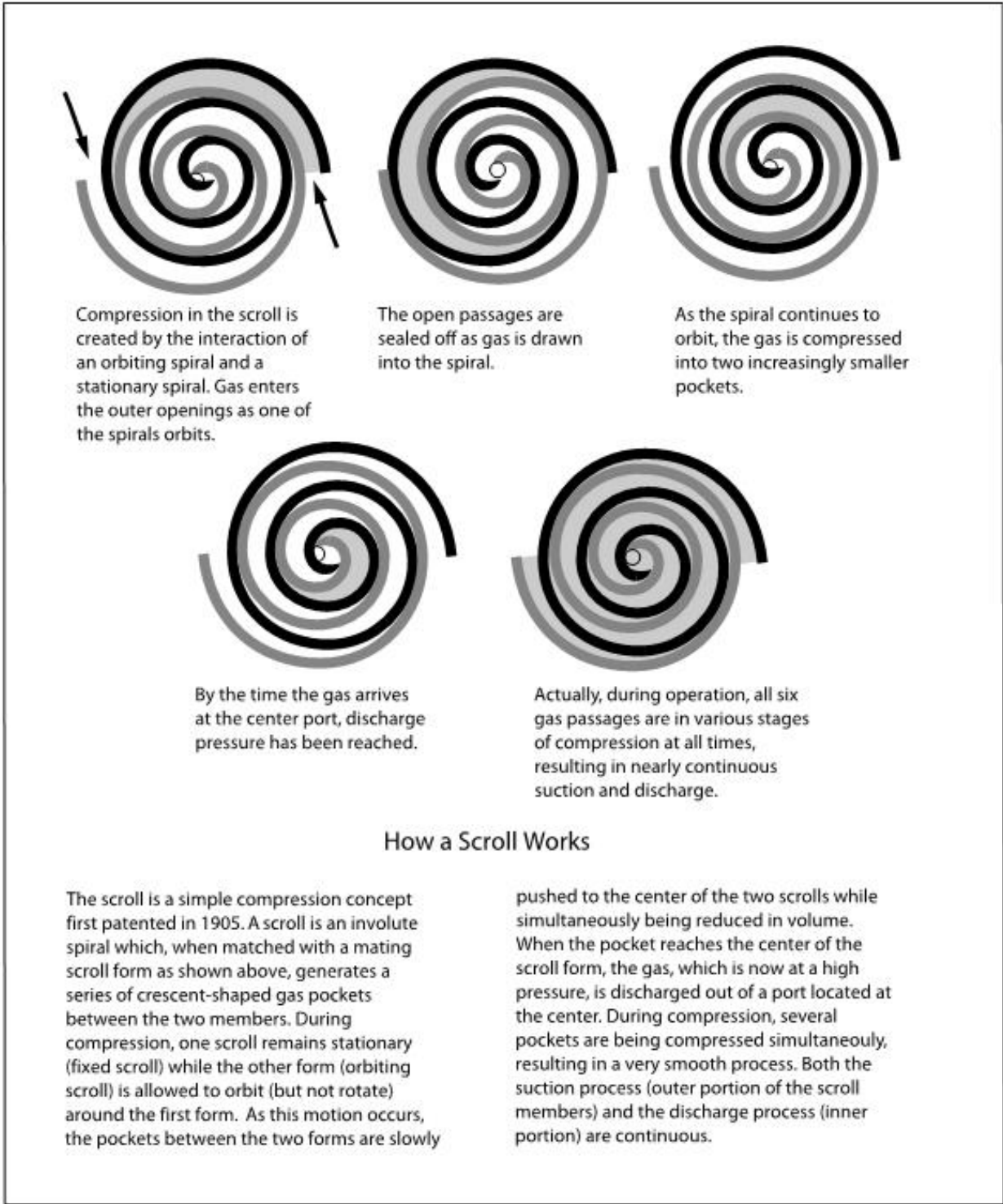

Figure 7

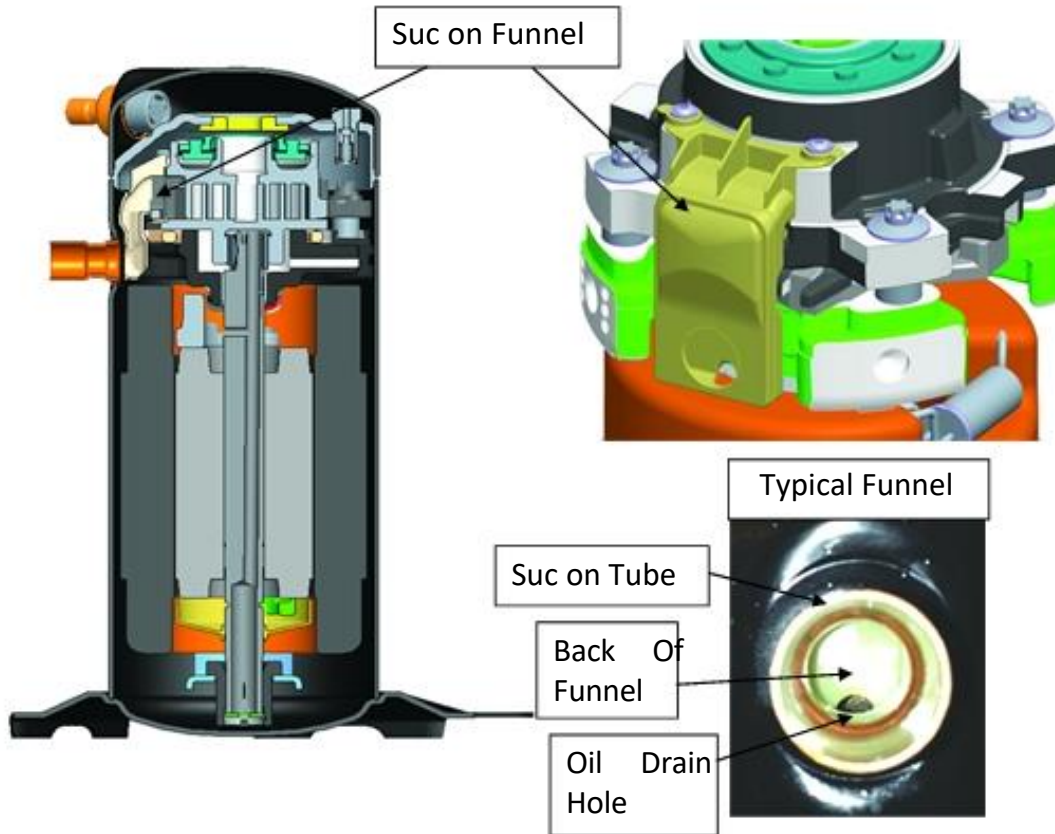

Figure 8 - Suction Funnel Diagram

Table 2
Field Application Test

Outdoor Ambient	85°F (29°C)	95°F (35°C)	105°F (40°C)
System On-Time (Minutes)	7	14	54
System Off-Time (Minutes)	13	8	6
Number of On/Off Cycles	5	5	4

Table 3
Design Configurations

Recommended Configuration	
Component	Description
Tubing Configuration	Shock loop
Service Valve	"Angled valve" fastened to unit
Suction muffler	Not required
Alternate Configuration	
Component	Description
Tubing Configuration	Shock loop
Service Valve	"Straight through" valve not fastened to unit
Mass / Suction muffler	May be required (Acts as dampening mass)

Table 4 - Refrigerant Charge Limits

Model	Compressor Charge Limit		System Charge Limit	
	Pounds	kg	Pounds	kg
ZP10-31K6	8	3.6	9.6	4.4
ZP34-54K6	10	4.5	12	5.4

Table 5 - Compressor Accessories

Part Category	Part Description	Part Number	Models	Notes
Mounting	Compressor Mounting Kit	527-0044-15	ZP10-31K6	30-35 Durometer
	Compressor Mounting Kit	527-0116-00	ZP34-54K6	35-45 Durometer
Crankcase Heater	Crankcase Heater, 120V, 40W	018-0094-01	ZP10-31K6	21" Leads
	Crankcase Heater, 240V, 40W	018-0094-00		21" Leads
	Crankcase Heater, 480V, 40W	018-0094-03		21" Leads
	Crankcase Heater, 120V, 40W	018-0096-01	ZP34-54K6	21" Leads
	Crankcase Heater, 240V, 40W	018-0096-00		21" Leads
	Crankcase Heater, 480V, 40W	018-0096-02		21" Leads
	Crankcase Heater, 575V, 40W	018-0096-03		21" Leads
	Crankcase Heater, 240V, 40W	018-0096-04		48" Leads
	Crankcase Heater, 480V, 40W	018-0096-05		48" Leads
	Crankcase Heater Junction Box	998-7026-00	ZP34-54K6	
Electrical	Grounding Screw	100-0605-00	All Models	10-32 x 8mm Long, Taptite Screw
	Molded Plug	529-0370-00		Universal Plug, 10 Gauge, 42" Leads
	Molded Plug Retainer Clip	032-0717-00		Optional Part, Locks the Molded Plug To Fence
	Flexible Metal Conduit Retainer	032-7051-01		Optional Part, Use with 032-0717-00
	Run Capacitor	Refer to Online Product Information at www.EmersonClimate.com for Model Specific Requirements		
	Start Capacitor			
	Start Relay			
	SecureStart™	943-0120-00	All Models	1-Phase Only
Diagnostics & Protection	CoreSense™ Diagnostics Module	971-0066-00	All Models	2-Wire Module, 1-Phase Only
	CoreSense™ Diagnostics Module	971-0067-00		3-Wire Module, 1-Phase Only
	Comfort Alert™ Module	543-0010-01		2-Wire Module, 1-Phase Only
	Comfort Alert™ Module	543-0032-00		1-Phase Only, Has "L" Terminal
	Comfort Alert™ Module	543-0038-02		3-Phase Only
	Comfort Alert™ Module	543-0067-00		1-Phase Only, Geothermal
	Discharge Line Thermostat	998-7022-02		Conduit Ready, fits 1/2" tube
Tandems	Suction Manifold	Future Offering		
	Discharge Manifold			
	Oil Equalization Tube			
	Gas Equalization Manifold			
	Tandem Mounting Kit, Compressor To Rails			
	Tandem Mounting Kit, Rails To Unit			
	Tandem Rails			

The contents of this publication are presented for informational purposes only and are not to be construed as warranties or guarantees, express or implied, regarding the products or services described herein or their use or applicability. Emerson Climate Technologies, Inc. and/or its affiliates (collectively "Emerson"), as applicable, reserve the right to modify the design or specifications of such products at any time without notice. Emerson does not assume responsibility for the selection, use or maintenance of any product. Responsibility for proper selection, use and maintenance of any Emerson product remains solely with the purchaser or end user.