

iCHiL



IC70CX **(firmware rel. 1.3)**

Index

1.	GENERAL WARNING	3
2.	GENERAL DESCRIPTION	4
3.	IC70CX FEATURES.....	4
4.	FRONT PANEL	5
5.	FIRST INSTALLATION.....	6
6.	PARAMETER PROGRAMMING WITH “HOTKEY”	6
7.	PARAMETER PROGRAMMING	6
8.	HOW TO LOCK THE KEYBOARD.....	7
9.	MAXIMUM AND MINIMUM TEMPERATURE MEMORIZATION.....	7
10.	SET POINT VISUALIZATION AND MODIFICATION	7
11.	HOW TO SWITCH ON OR SWITCH OFF THE INSTRUMENT	7
12.	REGULATION.....	8
13.	ALARMS	15
14.	SERIAL COMMUNICATION	16
15.	PARAMETERS	16
16.	INSTALLATION AND MOUNTING.....	22
17.	ELECTRICAL CONNECTIONS.....	22
18.	CONNECTIONS.....	22
19.	TECHNICAL DATA.....	23

1. General warning

1.1 Please read before using this manual

- This manual is part of the product and should be kept near the instrument for easy and quick reference.
- The instrument shall not be used for purposes different from those described hereunder. It cannot be used as a safety device.
- Check the application limits before proceeding.
- Dixell Srl reserves the right to change the composition of its products, even without notice, ensuring the same and unchanged functionality.

1.2 Safety Precautions

- Check the supply voltage is correct before connecting the instrument.
- Do not expose to water or moisture: use the controller only within the operating limits avoiding sudden temperature changes with high atmospheric humidity to prevent formation of condensation
- Warning: disconnect all electrical connections before any kind of maintenance.
- Fit the probe where it is not accessible by the End User. The instrument must not be opened.
- In case of failure or faulty operation send the instrument back to the distributor or to "Dixell S.r.l." (see address) with a detailed description of the fault.
- Consider the maximum current which can be applied to each relay (see Technical Data).
- Ensure that the wires for probes, loads and the power supply are separated and far enough from each other, without crossing or intertwining.
- In case of applications in industrial environments, the use of mains filters (our mod. FT1) in parallel with inductive loads could be useful.

Dixell S.r.l. reserves the right to change this manual even without notice.

2. General description

The IC70CX is a multifunction controller for boiler with heat pump with functions for sanitary hot water.

3. IC70CX features

N° OF KEYS	
6	●
RELAY OUTPUT	
4	●
DIGITAL INPUT	
1	Config
PROBES	
2 (NTC o Ptc)	Config
SERIAL OUTPUT	
TTL (ModBusRtu protocol)	●
SUPPLY	
230 Vac ($\pm 10\%$)	●
110 Vac ($\pm 10\%$)	Opt
DISPLAY	
3 digit with decimal point	●
OTHER	
Buzzer	Opt

- Config. = configurable by parameter
- Opt = optional
- ● = standard

4. Front panel



4.1 Display symbol

LED	MODE	MEANING
	Lighted	Compressor ON
	Blink	Compressor start up phase
	Lighted	Defrost on going
	Blink	Dripping time on going
	Lighted	Fan ON
	Blink	Fan start up phase
	Lighted	Alarm ON
	Lighted	Anti legionella cycle on going
	Lighted	Heater ON
°C/°F	Lighted	Unit of measure
°C/°F	Blink	Parameter programming phase



4.2 Keys

	MEANING
	Enable/disable the compressor (press 3 seconds)
	Start manual defrost
SET	Set point visualization
	To read max. stored temperature; in programming mode it browses the parameter codes or increases the displayed value; to enable the anti-legionella cycle.
	To read min stored temperature; in programming mode it browses the parameter codes or decreases the displayed value.
	Switch on/off the controller

5. First installation

5.1 How to set current time



Following first power on or after a period of power off it's necessary to program the time and day:

1. Enter the Pr1 programming menu, by pushing the SET +  keys for 3s.
2. The rtc parameter is displayed. Push the SET key to enter the real time clock menu.
3. The Hur (hour) parameter is displayed.
4. Push the SET and set current hour by  0  keys, then push SET to confirm the value.
5. Repeat the same operations on the Min (minutes) and dAy (day) parameters.

To exit: Push SET+ keys or wait for 15 secs without pushing any keys.

6. Parameter programming with "Hotkey"

6.1 Upload (parameters copy from instrument to HotKey)

1. The instrument has to be ON
2. Insert the Hotkey into the 5 ways connector, then press  key.
3. The display shows "uPL" blinking
4. At the end the display shows:
"End": programming operation is successful
"Err": programming operation is not successful. By pressing  key is possible to repeat the operation.



6.2 Download (parameters copy from HotKey to instrument)

The Hotkey has to be already programmed with a parameter map compatible with the instrument:

1. The instrument must not be powered
2. Insert the Hotkey into the 5 ways connector
3. Provide voltage to the instrument: **DOWNLOAD** procedure starts automatically. The display visualizes "doL" blinking
4. At the end the display shows:
"End" programming operation is successful
"Err" programming operation is not successful. remove the HotKey and repeat operation above.

7. Parameter programming





7.1 How to change a parameter value (Pr1 level)

1. Enter the Programming mode by pressing the Set +  keys for 3 seconds ("°C" or "°F" LED starts blinking).
2. Select the parameter to change then press the "SET" key to display its value
3. Use  or  to change its value.
4. Press "SET" to store the new value and move to the following parameter.

To exit: Press SET + UP or wait 15 seconds without pressing any key.

NOTE: the new value is stored even if the procedure ends for time out.

7.2 How to change a parameter value in the hidden menu (Pr2 level)

1. Enter the Programming mode by pressing the Set +  keys for 3 seconds ("°C" or "°F" LED starts blinking).
2. When a parameter is showed, press Set +  for 7 seconds; "Pr2" label is showed followed by first parameter on the list.
3. Select the parameter to change, then press the "SET" key to display its value.
4. Use  or  to change its value.
5. Press "SET" to store the new value and move to the following parameter.

To exit: Press SET + UP or wait 15 seconds without pressing any key.

NOTE: the new value is stored even if the procedure ends for time out.



7.3 How to move a parameter from the hidden menu (Pr2) to the first level (Pr1) and viceversa

Each parameter present in the HIDDEN MENU can be removed or moved into "THE FIRST LEVEL" (user level) by pressing "SET + .

In HIDDEN MENU when a parameter is present in First Level the decimal point is on.

8. How to lock the keyboard

8.1 Lock the keyboard



1. Keep pressed  +  (together) keys for more than 3 seconds.
2. "POF" message will be displayed and the keyboard will be locked. At this point it will be possible only to see the set point or the Max o Min stored temperature.
3. If a key is pressed more than 3 seconds, "POF" message will be displayed.

8.2 Unlock the keyboard



Keep pressed  +  (together) keys for more than 3 seconds, till the "Pon" message will be displayed.

9. Maximum and minimum temperature memorization

9.1 How to see minimum temperature

1. Press and release the  key.
2. "Lo" message will be displayed followed by the minimum temperature recorded.
3. By pressing the  key again or by waiting 5 seconds the normal visualization will be restored.

9.2 How to see the max temperature

1. Press and release the  key.
2. The "Hi" message will be displayed followed by the maximum temperature recorded.
3. By pressing the  key again or by waiting 5 seconds the normal display will be restored.

9.3 How to reset maximum and minimum recorded temperature

1. Hold press the SET key for more than 3 seconds, while the max or min temperature is displayed (rSt message will be displayed)
2. To confirm the operation the "rSt" message starts blinking and the normal temperature will be displayed.



10. Set point visualization and modification

10.1 HOW TO READ THE SETPOINT

Push and immediately release "SET" key: the display will show the Set point value.

Push and immediately release "SET" key or wait 5 seconds to display the normal visualization.

10.2 HOW TO CHANGE THE SETPOINT

1. Push the "SET" key for more than 2 seconds to change the Set point value;
2. The value of the set point will be displayed and the "°C" or "°F" led starts blinking;
3. To change the Set value push the  or  keys within 10 seconds
4. To memorise the new set point value push "SET" key again or wait 10 seconds.

11. How to switch on or switch off the instrument

By pressing  key it is possible to switch off (if previously was ON) or switch on (if previously was ON) the instrument.

12. Regulation

After a power on is possible to delay the loads regulation setting C01 parameter.

The type of the probes can be selected by C05 parameter:

- C05=PTC PTC probes are used
- C05=NTC NTC probes are used

The unit of measure of the temperature can be:

- C06=°C temperatures are showed in °C
- C06=°F temperatures are showed in °F

For °C visualization it is possible to choose if the temperature has to be showed with decimal point or not:

- C07=DE temperatures are showed with decimal point
- C07=°F temperatures are showed without decimal point

12.1 Compressor

The compressor is used to maintain the set point temperature (S01 parameter).

It is possible to set a minimum OFF time (parameter C02) to avoid consecutive short cycles of the compressor.

If the regulation probe is faulty, the compressor will run with ON/OFF cycles defined by C03 and C04 parameters.

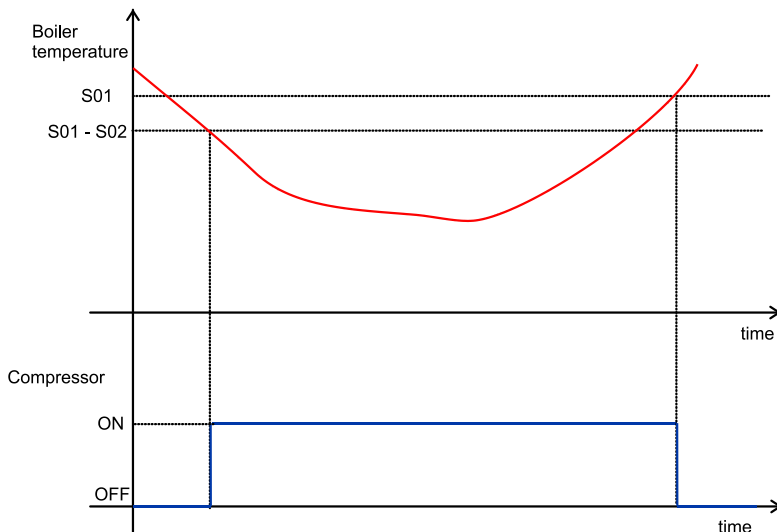

12.2 Heaters

Heaters can be used to integrate the compressor to produce hot water; to the compressor contribution is possible to add electrical heaters contribution if the boiler temperature falls below a determined value set by parameter.

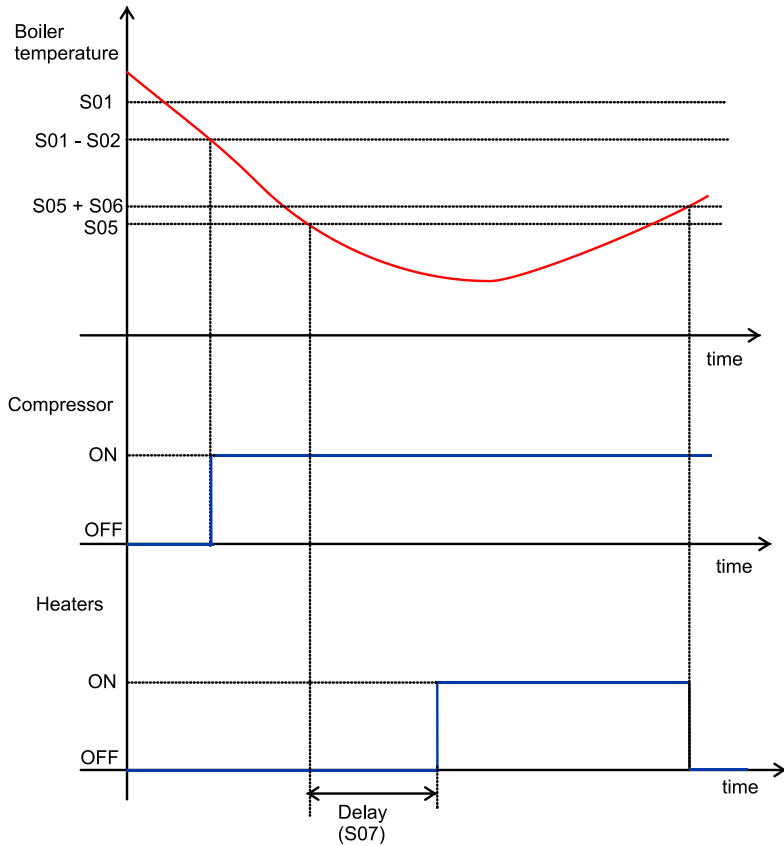

12.3 Compressor and heaters regulation in relation to ambient temperature

It is possible to set an ambient temperature (parameter S08) under which the heaters, if not previously ON, are switched ON. It is also possible to switch OFF the compressor if the ambient temperature falls below a determined temperature (parameter S10).

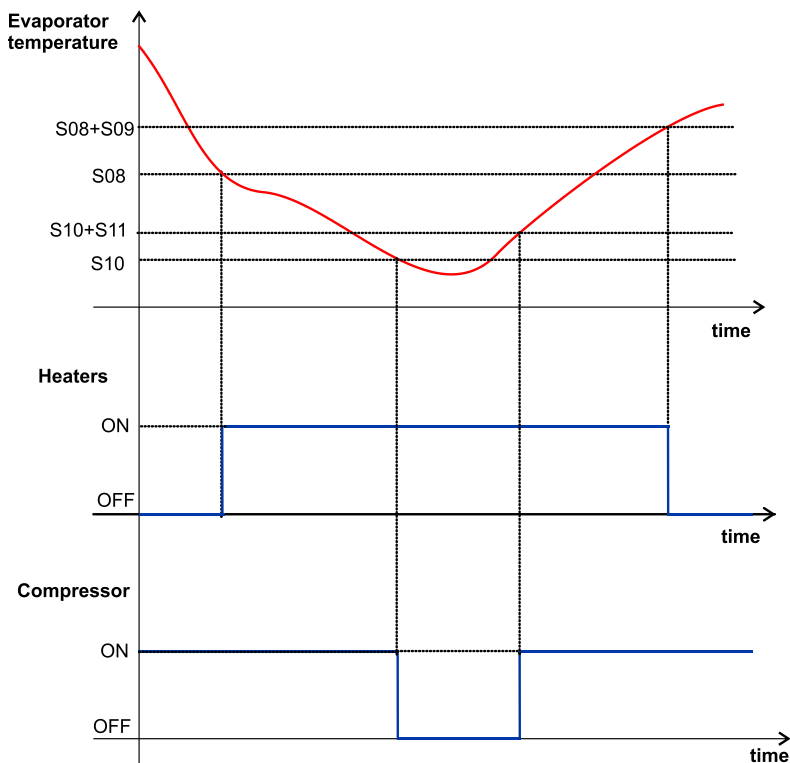

12.4 How to disable the compressor

It is possible to disable the compressor pressing  key for 3 seconds. If the heaters are available, they are used to substitute the compressor. If the compressor is disabled, it remains in that state also after a power off.

12.5 Fan

Fan operation mode can be set by F01 parameter:

- **F01 = C_n** fan runs with the compressor, OFF in defrost
- **F01 = o_n** fan always ON, OFF in defrost
- **F01 = C_Y** fan runs with the compressor, ON in defrost
- **F01 = o_Y** fan always ON, ON in defrost

It is possible to switch off the fan if evaporator temperature falls below "F02" (Temperature to stop fan).

It is possible to set a delay to restart the fan after a defrost with the parameter "F03".

12.6 Anti legionella cycle

The Anti-Legionella cycle is a procedure used to eliminate legionella bacteria; during the cycle the water temperature is increased to S12 set point for a period of time defined by parameter S16 (expressed in tens of minutes).

Anti-legionella cycle can be activated:

- **At Power-On:** if the parameter S14=y, the cycle is activated every time the instrument is switched on.
- **Manually:** by pressing  key for 3 seconds it is possible to activate/deactivate antilegionella cycle.
- **Day of the week:** internal clock is used (clock has to work correctly). The cycle is activated once a week (day can be set by S17 parameter) at a determined hour (parameter S15) and the temperature will be maintained for S16 time. If the internal clock goes on error during anti legionella cycle, the cycle ends when S16 time is elapsed.

Time S16 starts counting when the water temperature reach S12 set point.

To start the cycle is necessary:

- a. the instrument mustn't be on alarm
- b. the instrument mustn't be OFF (stand-by)
- c. a relay has to be configured as heaters
- d. S16 parameter has to be bigger than zero
- e. S17 parameter has to be set different to "nu" (not used)

12.6.1 Anti legionella cycle operation mode

During anti-Legionella cycle the operation mode is the following:

- if boiler temperature is lower than compressor set point, only the compressor is switched on
- if boiler temperature is between compressor set point and anti legionella set point ($S12 > \text{boiler temperature} > S01$), only heaters are switched on. Differential of regulation is S02 for both set point (compressor and anti legionella)
- if boiler temperature is higher than anti legionella set point, both compressor and heaters are off

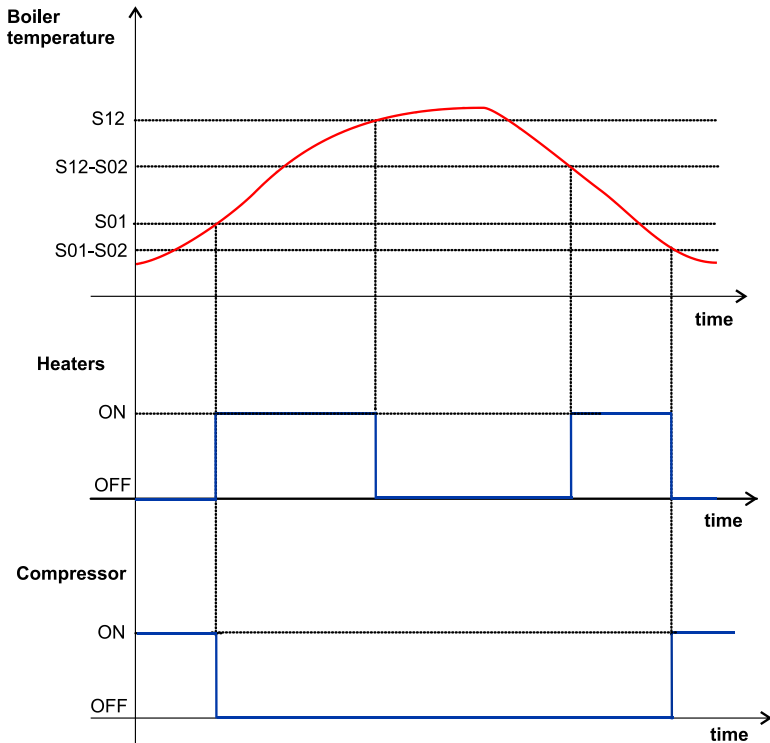

12.6.2 Anti-legionella time out alarm

When the cycle starts, the controller activates the compressor or the heaters until the temperature reaches the set point value legionella.

If the compressor can not be activated because an alarm block it, the heaters are switched on to substitute the compressor. When the anti legionella cycle starts, a maxim time to reach the set point starts counting; if the set is not reached within this time, the message "LGn" is showed and the cycle is interrupted.

The alarm can be silenced and removed by pressing a button.

12.7 Defrost

To disable the defrost set parameter d05=0.

Three defrost operation mode are selectable:

- **d01=EL** defrost with electrical heaters (compressor OFF in defrost and dripping time)
- **d01=in** hot gas defrost (compressor On in defrost and OFF during dripping time)
- **d01=Cr** reversing gas cycle defrost

Defrost is done by interval time set by d03 parameter; if d06>0, the defrost is delayed by this time.

The defrost lasts maximum d05 time; when d05 time is elapsed and the defrost is still ongoing, it ends.

If d05=0, the defrost is disabled.

During defrost the high and lower temperature alarm (HA and LA) are disabled; after defrost the alarms detection restart after 20 minutes (time fixed and not modifiable).

After the defrost the dripping time starts and lasts d07 time.

12.7.1 Defrost visualization

It is possible to choose what to visualize during defrost and dripping time.

If d08=it (visualization of the temperature measured when the defrost starts) it valid only if C02=P1 or C02=dr, otherwise the display shows actual temperature.

Defrost visualization:

parameter d08 = rt	default temperature visualization (parameter C22)
parameter d08= it	default temperature when defrost is started
parameter d08= SEt	set point visualization
parameter d08= dEF	"dEF" label visualization

Dripping time visualization:

parameter d08= rt	default temperature visualization (parameter C22)
parameter d08= it = SEt = dEF	default temperature when defrost is started

Visualization during d06 start defrost delay time:

parameter d08= rt	default temperature visualization (parameter C22)
parameter d08= it = SEt = dEF	default temperature when defrost is started

12.7.2 Reversing gas cycle defrost

When the defrost starts, the sequence is as follows:

- Step1: the compressor and the fans are turned off (if not already turned off due to normal regulation)
- Step2: the 4-way valve (defrost relay) is activated after d11 seconds (counted from Step 1)
- Step 3: the compressor is turned on after d11 seconds (counted from Step 2); the fans follow the behavior given by parameter F01

The defrosting process continues as standard setting.

End defrost:

- Step1: when the end defrost conditions are satisfied, the compressor is switched off
- Step 2: the 4-way valve (defrost relay) is switched off after d11 seconds (counted from Step 1)
- Step 3: after further d11 seconds the controller will return to the heating mode

The counting of time between two defrosts is reset.

The drawing below shows the status of the loads if F01=C-n.

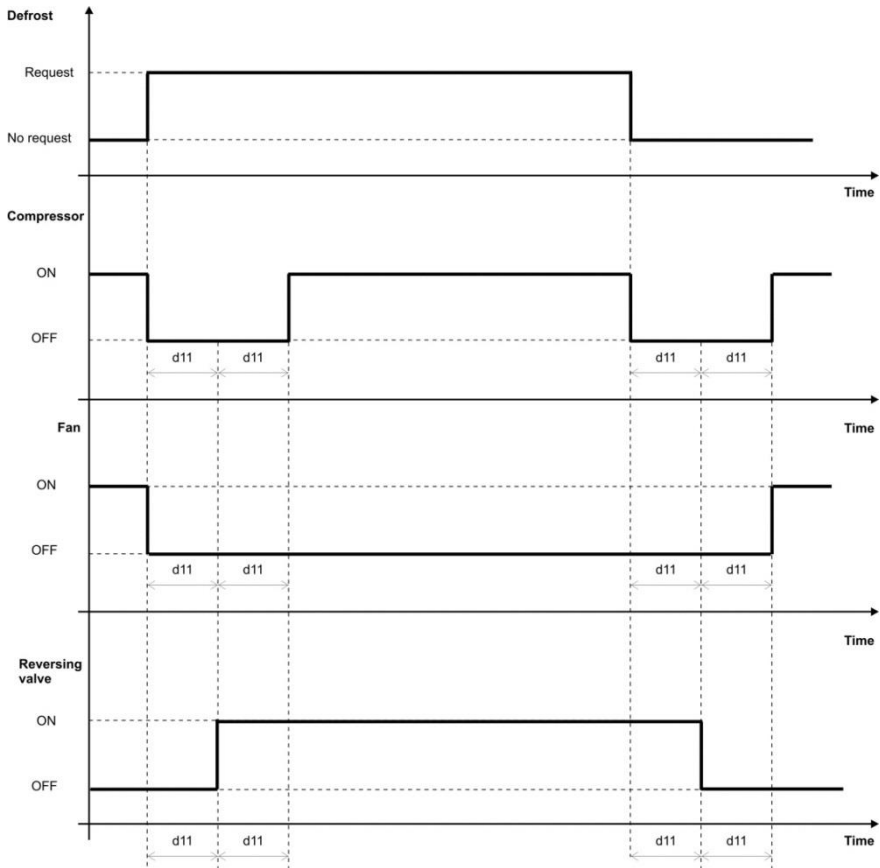

12.7.3 Particular conditions

If during defrosting the user sets the instrument OFF, defrosting continues and only at the end of the same the instrument will turn off.

In case of generating alarms during the defrost cycle, if the alarm causes the compressor switching off the defrost will be stopped.

The alarm pressure switch is inhibited for 1 minute after defrosting.

12.7.4 Manual start defrost

It is possible to start the defrost pressing $\star\star$ key for 2 seconds.

In case of manual defrost procedure, the d_{06} delay is not considered.

13. Alarms

Temperature alarms:

- can be absolute or relative to the set point (selection by parameter A01)
- it is possible to choose the reference probe (parameters A02 and A10)
- alarm signalling can be delayed by A06 and A14 parameters
- compressor and heater can be switched off in case of temperature alarm (parameters A07, A08, A16 and A17)
- temperature alarm detection can be delayed at the power by A09 and A15 parameters

Temperature alarm detection is disabled in the following cases:

- delay at power on (parameter C01)
- defrost, dripping time or anti legionella cycle on going
- for 20 minutes after the defrost

13.1 Alarm codes

Message	Cause	Outputs
"P1"	Room probe failure	Compressor off or cycles for "C03" and "C04" time
"P2"	Evaporator probe failure	Defrost ends for maximum duration
"P3"	Third probe failure	Outputs unchanged
"P4"	Fourth probe failure	Outputs unchanged
"HA"	Maximum temperature alarm	See parameters A07, A08, A16 and A17
"LA"	Minimum temperature alarm	See parameters A07, A08, A16 and A17
"HA2"	Condenser high temperature	It depends on the "A17" parameter
"LA2"	Condenser low temperature	It depends on the "A16" parameter
"EA"	External alarm	Output unchanged
"CA"	Serious external alarm (C15=bAL)	All outputs OFF
"CA"	Pressure switch alarm (C15=PAL)	All outputs OFF
"rtc"	Real time clock alarm	Alarm output ON; Other outputs unchanged; Defrosts according to par. "d03" Set real time clock has to be set
"rtF"	Real time clock board failure	Alarm output ON; Other outputs unchanged. Defrosts according to par. "d03"
"Lgn"	Set of Anti-Legionella not reached during S16 time	Loads according to SET regulation

13.2 Alarm reset

P1, **P2**, and **P4** probe alarms start some seconds after the fault of the related probe; they automatically reset some seconds after the probe restarts normal operation.

Check connections before replacing the probe.

Temperature alarms **HA**, **LA**, **HA2** and **LA2** automatically stop as soon as the temperature returns to normal values.

Alarms **EA** and **CA** (with C15=bAL) recover as soon as the digital input is disabled; if the digital input is configured as pressostat (C15=bAL), reset is manually after switching off the lchill.

rtC alarm resets after clock setting; **rtF** alarm means hardware problem and is necessary to replace the lchill.

Alarm **Lgn** recovers by pressing a key, regulation on SET.

13.3 Other messages

Pon	Keyboard unlocked
PoF	Keyboard locked
noP	In programming mode: none parameter is present in Pr1 On the display or in dP2, dP3, dP4: the selected probe is nor enabled

14. Serial communication

The controller has a serial output that can be used for:

- upload and download of the parameter map by HotKey
- upload and download of the parameter map by Wizmate software
- XWEB supervising system

Serial address can be set by C26 parameter.

15. Parameters

rtC	Access to clock menu		
Hur	Hour	0 ÷ 23	
Min	Minutes	0 ÷ 59	
dAy	Day of the week	Sun + SA _t	
S 01	Set point	S03 + S04	0,1 °C / 1°F
S 02	Differential	0,1°C + 25,5°C 1°F + 45°F	0,1°C / 1°F
S 03	Minimum value of the set point	-55,0°C + S01 -67°F + S01	0,1°C / 1°F
S 04	Maximum value of the set point	S01 + 150,0°C S01 + 302°F	0,1°C / 1°F
S 05	Set point heater for integration to compressor	-55,0°C ÷ 110°C -67°F ÷ 230 °F	
S 06	Differential heater for integration to compressor	0,1°C + 25,5°C 1°F + 45°F	
S 07	heater activation delay	0 ÷ 255 (min.)	1 minute
S 08	Set point heater on evaporator probe	-55,0°C + 110°C -67°F + 230 °F	
S 09	Differential heater on evaporator probe	0,1°C + 25,5°C 1°F + 45°F	
S 10	Set point to switch off compressor on evaporator probe	-55,0°C + 110°C -67°F + 230 °F	
S 11	Differential to switch on compressor on evaporator probe	0,1°C + 25,5°C 1°F + 45°F	
S 12	Set point for anti legionella cycle	-55,0°C + 150,0°C -67°F + 302°F	
S 13	Time to reach anti legionella set point	0 ÷ 24H0(144)	10 minute
S 14	First defrost after start-up	n(0) - Y(1)	-
S 15	Antilegionella start time	0 + 23h5 (143)	10 minutes
S 16	Antilegionella duration	0 + 255 (min.)	1 minute
S 17	Day to activate anti legionella cycle	Sun(0) + SA _t (6) - nu(7)	

C 01	Delay to start regulation at start up	0 + 255 (min.)	1 minute
C 02	Compressor anti-short cycle delay	0 ÷ 50 (min.)	1 minute
C 03	Compressor ON time if regulation faulty probe	0 + 255 (min.)	1 minute

C 04	Compressor OFF time if regulation faulty probe	0 ÷ 255 (min.)	1 minute
C 05	Probe selection	PtC(0) - nC(1)	
C 06	Temperature unit of measure	°C(0) - °F(1)	-
C 07	Temperature visualization resolution	dE(0) - in(1)	-
C 08	Pb2 Evaporator probe presence	n(0) - Y(1)	-
C 09	Pb3 probe presence	n(0) - Y(1)	-
C 10	Pb4 probe presence	n(0) - Y(1)	-
C 11	Pb1 Regulation probe calibration	-12,0°C ÷ 12,0°C -21°F ÷ 21°F	0,1°C / 1°F
C 12	Pb2 Evaporator probe calibration	-12,0°C ÷ 12,0°C -21°F ÷ 21°F	0,1°C / 1°F
C 13	Pb3 probe calibration	-12,0°C ÷ 12,0°C -21°F ÷ 21°F	0,1°C / 1°F
C 14	Pb4 probe calibration	-12,0°C ÷ 12,0°C -21°F ÷ 21°F	0,1°C / 1°F
C 15	Digital input 1 configuration	EAL(0) - bAL(1) - PAL(2) - onF(3)	-
C 16	Digital input 1 polarity	OP(0) - CL(1)	-
C 17	Second relay configuration	dEF(0) - FAn(1) - ALr(2) - AUS(3) -	-
C 18	Third relay configuration	dEF(0) - FAn(1) - ALr(2) - AUS(3) - OnF(4) - HEt(5)	-
C 19	Fourth relay configuration	dEF(0) - ALr(1)	-
C 20	Not used		
C 21	Not used		
C 22	Not used		
C 23	Firmware Release (only reading)		
C 24	Map code (only reading)		
C 25	Serial address	1 ÷ 247	
C 26	Kind of action for auxiliary relay	CL(0) - Ht(1)	
C 27	Set point of auxiliary relay	-55,0°C ÷ 150,0°C -67°F ÷ 302°F	
C 28	Differential of auxiliary relay	0,1°C ÷ 25,5°C 1°F ÷ 45°F	
C 29	Auxiliary relay status during defrost	n(0) - Y(1)	
C 30	Probe selection for auxiliary relay	nP(0) - P1(1) - P2(2) - P3(3) - P4(4)	
C 31	Probe 1 value (only visualization)	(probe value)	
C 32	Probe 2 value (only visualization)	(probe value)	
C 33	Probe 3 value (only visualization)	(probe value)	
C 34	Probe 4 value (only visualization)	(probe value)	

d01	Defrost selection	EL(0) - in(1) - Cr (2)	-
d02	Defrost end temperature	-55,0°C ÷ 50,0°C -67°F ÷ 122°F	1°C / 1°F
d03	Interval between defrost cycles	0 ÷ 255 (ore)	1 hour
d04	Interval between defrost cycles time resolution	Hur(0) - Min(1)	-

d05	Maximum duration of the defrost	0 + 255 (min.)	1 minute
d06	Start defrost delay	0 + 255 (min.)	1 minute
d07	Draining time	0 + 255 (min.)	1 minute
d08	Visualization during defrost	$r(0) - i(1) - SE(2) -$ $\frac{1}{255}$	-
d11	Delay to reverse the status of 4 way valve	0 + 255 (sec.)	1 second

F 01	Fan operating mode	$C_n(0) - O_n(1) -$ $C_Y(2) - O_Y(3)$	-
F 02	Fan stop temperature	-55.0°C + 50.0°C -67°F + 122°F	1°C / 1°F
F 03	Fan delay after defrost	0 + 255 (min.)	1 minute
F 04	Fan on time with compressor off	0+15 (min.)	1°C / 1°F
F 05	Fan off time with compressor off	0+15 (min.)	1°C / 1°F

A 01	Temperature alarms configuration	rE(0) - Ab(1)	-
A 02	Probe selection for temperature alarms	nP(0) - P1(1) - P2(2) - P3(3) - P4(4)	-
A 03	Set point maximum temperature alarm	°C[0.0° + 50.0° o ALL + 150.0°]	0,1°C / 1°F
A 04	Set point minimum temperature alarm	°C[0.0° + 50.0° o - 55.0° + ALU] °F[0° + 90° o - 67.0° + 45°F]	0,1°C / 1°F
A 05	Differential for temperature alarm	[0,1°C + 25,5°C] [1°F + 45°F]	
A 06	Temperature alarm delay	0 + 255 (min.)	1 minute
A 07	Compressor and heaters off in case of low temperature alarm	n(0) - Y(1)	
A 08	Compressor and heaters off in case of high temperature alarm	n(0) - Y(1)	
A 09	Temperature alarm detection delay at start up	0 + 24H0(144)	10 minutes
A 10	Probe selection for temperature alarm 2	nP(0) - P1(1) - P2(2) - P3(3) - P4(4)	
A 11	Low temperature alarm 2 set point (absolute temperature)	[-55.0°C + 150.0°C] [-67°F + 302°F]	
A 12	High temperature alarm 2 set point (absolute temperature)	[-55.0°C + 150.0°C] [-67°F + 302°F]	0,1°C / 1°F
A 13	Temperature alarm 2 differential	[0,1°C + 25,5°C] [1°F + 45°F]	
A 14	Temperature alarm 2 delay	0 + 254 (min.) . 255 = ALL	1 minute
A 15	Temperature alarm delay at power-on	0 + 24H0(144)	
A 16	Compressor and heaters switched off in case of low temperature alarm 2	n(0) - Y(1)	
A 17	Compressor and heaters switched off in case of high temperature alarm 2	n(0) - Y(1)	-
A 18	Alarm relay switched off by pushing a key	n(0) - Y(1)	-
A 19	Digital input 1 alarm delay	0 + 255 (min.)	1 minute

A 20	Number of activation of pressure switch	0 ÷ 15	
A 21	Alarm relay polarity	OP(0) - CL(1)	-

15.1 Parameter description

TO SET CURRENT TIME AND WEEKLY HOLIDAYS

- rtC Real time clock menu:** to set the time and date and defrost start time.
Hur Current hour (0 ÷ 23 h)
Min Current minute (0 ÷ 59min)
dAY Current day of the week (Sun ÷ SA)

REGULATION

- S01 Set point Regulation set point** (S3 ÷ S04)
S02 Differential (0,1 ÷ 25,5°C / 1÷255 °F) Intervention differential for set point
S03 Minimum Set Point: (- 50°C÷C01/-58°F÷C01): Set the minimum value for set point
S04 Maximum Set Point: (S01÷110°C/ S01÷230°F). Set the maximum value for set point.
S05 Set point resistance for integration to compressor Set point activation of the resistance as integration to the compressor
S06 Differential resistance for integration to compressor (0,1°C ÷ 25,5°C): Differential for resistance regulation as integration to the compressor
S07 Resistance activation delay: delay to switch on the resistance
S08 Set point resistance on evaporator probe: Set point for resistance activation
S09 Differential resistance on evaporator probe: Differential for resistance regulation
S10 Set point to switch off compressor on evaporator probe: Set point to switch off the compressor if evaporator temperature falls below a determined temperature
S11 Differential to switch on compressor on evaporator probe: Differential of compressor de-activation
S12 Set point for anti legionella cycle: Set point of the anti legionella cycle
S13 Time to reach anti legionella set point: maximum time to reach the anti-legionella set point
S14 Anti legionella cycle at start-up; this parameter allow to enable the anti legionella cycle at the power on
S15 Antilegionella start time; hour of anti legionella cycle activation
S16 Antilegionella duration; the anti legionella temperature has to be maintained for this time;
S17 Day to activate anti legionella cycle; day of anti legionella cycle activation

COMPRESSOR

- C01 Outputs activation delay at start up:** (0÷255 min) This function is enabled at the initial start up of the instrument and inhibits any output activation for the period of time set in the parameter.
C02 Anti-short cycle delay: (0÷50 min) minimum interval between compressor stop and following restart.
C03 Compressor ON time with faulty probe: (0÷255 min) time during which the compressor is active in case of faulty thermostat probe. With CO3=0 compressor is always OFF.
C04 Compressor OFF time with faulty probe: (0÷255 min) time during which the compressor is OFF in case of faulty thermostat probe. With CO4=0 compressor is always active.

CONFIGURATION

- C05 Type of probe:** (Ptc = probe PTC; ntc= probe NTC).
C06 Temperature measurement unit: °C = Celsius; °F = Fahrenheit.
When the measurement unit is changed, temperature set point and hysteresis have to be checked and modified if necessary.
C07 Resolution (only for °C): (in = 1°C; dE = 0.1 °C) allows decimal point displaying.
C08 Evaporator probe presence (P2): (n = Not present: defrost stops by time; y = present: defrost stops by temperature).
C09 Pb3 probe presence
C10 Pb4 probe presence
C11 Pb1 Thermostat probe calibration: (-12.0÷12.0°C) allows to adjust reading value of thermostat probe
C12 Pb2 Evaporator probe calibration (P2): (-12.0÷12.0°C) allows to adjust reading value of evaporator probe

C13 Pb3 probe calibration

C14 Pb4 probe calibration

C15 Digital input configuration:

EAL = signalling alarm; bAL = alarm to stop the machine; PAI = pressure switch alarm; onF = remote ON/OFF

C16 Digital input polarity: oP= the digital input is activated by opening the contact. CL= the digital input is activated by closing the contact.

C17 Second relay configuration (dEF - FAn - ALr - AUS - OnF- HEt)

C18 Third relay configuration (dEF - FAn - ALr - AUS - OnF- HEt)

C19 Fourth relay configuration (dEF - FAn - ALr - AUS - OnF- HEt)

C20 Not used

C21 Not used

C22 Not used

C23 Software release (only reading)

C24 Parameter table code (only reading)

C25 Serial address (0÷244)

C26 Kind of action of auxiliary regulation; CL = cooling, HT = heating

C27 Set point auxiliary regulation Auxiliary regulation set point

C28 Differential auxiliary regulation Auxiliary regulation differential

C29 Auxiliary regulation stopped during defrost; allows to stop auxiliary regulation during defrost

C30 Auxiliary regulation probe selection

C31 Thermostat probe visualization: it allows to read thermostat probe

C32 Evaporator probe visualization: it allows to read evaporator probe

C33 Third probe visualization: it allows to read third probe

C34 Fourth probe visualization: it allows to read fourth probe

DEFROST

d01 Defrost type: EL = electrical heater; in = hot gas; Cr = reversing gas cycle

d02 End defrost temperature: (-50÷50 °C/ -58÷122°F) sets the end defrost temperature.

d03 Interval between defrost cycles: (0÷120 h) Determines the time interval between the beginning of two defrost cycles.

d04 Resolution for d03: Sets the resolution for the d03 parameter (**Hur** = hours, **Min** = minutes).

d05 Maximum length for defrost: (0÷255min) If **C08=n** (not evaporator probe: timed defrost) it sets the defrost duration, if **C08=y** (defrost end based on temperature) it sets the maximum length for defrost.

d06 Start defrost delay: (0÷59min) This is useful when different defrost start times are necessary to avoid overloading the plant.

d07 Drip time: (0÷120 min) time interval between reaching defrost termination temperature and the restoring of the control's normal operation. This time allows the evaporator to eliminate water drops that might have formed due to defrost.

d08 Temperature displayed during defrost: (**rt** = real temperature; **it** = temperature at defrost start; **SEt** = set point; **dEF** = "dEF" label)

d11 Delay to reverse the status of 4 way valve: at beginning and at the end of the defrost the 4-way valve changes his status once this time has elapsed

FAN

F01 Fans operating mode:

C-n= runs with the compressor, OFF during defrost;

o-n = continuous mode, OFF during defrost;

C-Y = runs with the compressor, ON during defrost;

o-Y = continuous mode, ON during defrost

F02 Fans stop temperature: (-50÷50°C/122°F) evaporator temperature above which fans are OFF.

F03 Fans delay after defrost: (0÷255min) Interval between end of defrost and evaporator fans start.

F04 Fan ON time: (0÷15 min) **with** F01 = C_n or C_y (fan activated in parallel with compressor), it sets the evaporator fan ON cycling time when the compressor is off. With F05 =0 and F06 ≠ 0 the fan are always off, with F05=0 and F06 =0 the fan are always off.

F05 Fan OFF time: (0÷15 min) **with** F01 = C_n or C_y (fan activated in parallel with compressor), it sets the evaporator fan off cycling time when the compressor is off. With F05 =0 and F06 ≠ 0 the fan are always off, with F05=0 and F06 =0 the fan are always off.

TEMPERATURE ALARMS

A01 Temperature alarms configuration: (Ab; rE)

Ab= absolute temperature: alarm temperature is given by the ALL or ALU values

rE = temperature alarms are referred to the set point.

A02 Probe selection for boiler temperature alarm: P1 = Probe 1; P2 = Probe 2; P3 = Probe 3; P4 = Fourth probe

A03 Maximum temperature alarm: (SET+110°C; SET+230°F) when this temperature is reached the alarm is enabled, after the "A06" delay time.

A04 Minimum temperature alarm: (-50.0 ÷ SET°C; -58÷230°F) when this temperature is reached the alarm is enabled, after the "ALd" delay time.

A05 Differential for temperature alarm/fan recovery: (0,1+25,5°C; 1+45°F) Intervention differential for recovery of temperature alarm. It's also used for the restart of the fan when the F02 temperature is reached.

A06 Temperature alarm delay: (0+255 min) time interval between the detection of an alarm condition and alarm signalling.

A07 Compressor and heater off with boiler low temperature alarm:

n = no: compressor keeps on working; Y = yes, compressor is switched off till the alarm is present, in any case regulation restarts after C02 time at minimum

A08 Compressor and heater off with boiler high temperature alarm:

n = no: compressor keeps on working; Y = yes, compressor is switched off till the alarm is present, in any case regulation restarts after C02 time at minimum

CONDENSER ALARM TEMPERATURE

A09 Exclusion of temperature alarm at startup: (from 0.0 min to 23.5h) time interval between the detection of the temperature alarm condition after instrument power on and alarm signalling.

A10 Probe selection for temperature alarm 2: nP = no probe; P1 = thermostat probe; P2 = evaporator probe; P3 = configurable probe; P4 = Probe 4.

A11 Set point low temperature alarm 2: (-55+150°C) when this temperature is reached the LA2 alarm is signalled, possibly after the A14 delay

A12 Set point high temperature alarm 2: (-55+150°C) when this temperature is reached the HA2 alarm is signalled, after the A14 delay.

A13 Differential for temperature 2: (0,1+25,5°C; 1+45°F).

A14 Temperature alarm 2 delay: (0+255 min) time interval between the detection of the condenser alarm condition and alarm signalling.

A15 Temperature alarm exclusion at start up: (from 0.0 min to 23.5h, res. 10min).

A16 Compressor and heater off with low temperature alarm of boiler: n = no: compressor and heater keep on working; Y = yes, compressor and heater are switched off till the alarm is present, in any case regulation restarts after C02 time at minimum.

A17 Compressor and heater off with high temperature alarm of condenser: n = no: compressor and heater keeps on working; Y = yes, compressor and heater are switched off till the alarm is present, in any case regulation restarts after C02 time at minimum.

A18 Alarm relay silencing:

n= silencing disabled: alarm relay stays on till alarm condition lasts,

y =silencing enabled: alarm relay is switched OFF by pressing a key during an alarm.

A19 (0÷255 min)

with C15= EAL or C15 = bAL digital input alarm delay: delay between the detection of the external alarm condition and its signalling.

with C15 = PAL: time for pressure switch function: time interval to calculate the number of the pressure switch activation.

A20 Pressure switch number: (0 ÷15) Number of activation of the pressure switch, during the "A19" interval, before signalling the alarm event (C15= PAL)

If the A20 activation in the did time is reached, switch off and on the instrument to restart normal regulation.

A21 Alarm relay polarity

16. Installation and mounting

Instrument **IC70CX** shall be mounted on vertical panel, in a 29x71 mm hole, and fixed using the special bracket supplied. The temperature range allowed for correct operation is 0÷60 °C. Avoid places subject to strong vibrations, corrosive gases, excessive dirt or humidity. The same recommendations apply to probes. Let air circulate by the cooling holes.

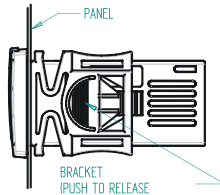

17. Electrical connections

The instrument is provided with screw terminal block to connect cables with a cross section up to 2,5 mm². Before connecting cables make sure the power supply complies with the instrument's requirements. Separate the probe cables from the power supply cables, from the outputs and the power connections. Do not exceed the maximum current allowed on each relay, in case of heavier loads use a suitable external relay.

18. Connections

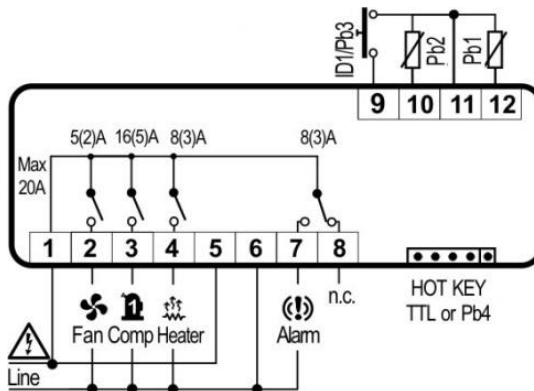

Terminal n°1: Common line for relays
Terminal n°2: output fan relay
Terminal n°3: output compressor relay
Terminal n°4: output heater relay
Terminal n°5: Line of supply voltage
Terminal n°6: Neutral of supply voltage
Terminal n°7: output alarm or defrost relay

Terminal n°9: digital input or Pb3 input probe
Terminal n°10: Pb2 input probe (boiler probe)
Terminal n°11: common line for digital input and/or probes
Terminal n°12: Pb1 input probe (evaporator probe)

TTL / Hotkey: TTL serial port to connect an Hotkey (for parameter programming) or to connect a Personal Computer for parameters programming using Wizmate software

19. Technical data

Housing: self extinguishing ABS

Case: frontal 32x74 mm; depth 60mm

Mounting: panel mounting in a 71x29mm panel cut-out

Protection: IP20; **Frontal protection:** IP65

Connections: Screw terminal block $\leq 2,5 \text{ mm}^2$ wiring

Power supply: according to the model: 230Vac $\pm 10\%$, 50/60Hz, 110Vac $\pm 10\%$, 50/60Hz

Power absorption: 3VA max

Display: 3 digits, red LED, 14,2 mm high;

Inputs: Up to 4 NTC or PTC probes

Digital input: free voltage contact

Relay outputs: compressor: SPST 16(6)A 250Vac

defrost: SPDT 8(3) A, 250Vac

fan: SPST 5A, 250Vac

aux: SPDT 8(3) A, 250Vac

Buzzer: optional

Data storing: on the non-volatile memory (EEPROM).

Internal clock back-up: 24 hours

Kind of action: 1B; **Pollution grade:** 2; **Software class:** A

Rated impulsive voltage: 2500V; **Overvoltage Category:** II

Operating temperature: 0+55 °C

Storage temperature: -25+60 °C

Relative humidity: 20+85% (no condensing)

Measuring and regulation range: NTC probe: -40+110 °C; **PTC:** -50+150 °C

Resolution: 0,1 °C or 1 °C or 1 °F (selectable)

Accuracy (ambient temp. 25°C): $\pm 0,7 \text{ °C} \pm 1 \text{ digit}$.

Dixell



Dixell S.r.l. - Z.I. Via dell'Industria, 27 - 32010 Pieve d'Alpago (BL) ITALY
Tel. +39.0437.9833 r.a. - Fax +39.0437.989313 - EmersonClimate.com/Dixell - dixell@emerson.com