





QUICK REFERENCE GUIDE

IC100CX EVO

(rel. 2.0)

INDEX

1	GENERAL WARNING	5
1.1	 PLEASE READ BEFORE USING THIS MANUAL	5
1.2	 SAFETY PRECAUTIONS	5
1.3	PRODUCT DISPOSAL (WEEE)	6
2	USING THE QUICK REFERENCE GUIDE	7
3	IC100 CX TABLE OF THE FEATURES	7
4	USER INTERFACE	8
4.1	MEANING OF THE LEDS	8
4.2	DISPLAY AND ICONS	8
5	DISPLAY LAYOUT	10
6	OTHER DISPLAY INFORMATION	10
6.1	READ THE SET POINT VALUE	10
6.2	MODIFY THE SET POINT	11
7	KEY FUNCTION	11
7.1	KEY COMBINANTION	12
8	FIRST INSTALLING	12
8.1	ON BOARD CLOCK (OPTIONAL)	12
8.2	RTC SETUP	12
9	PARAMETERS PROGRAMMING WITH THE “HOT KEY 64”	13
9.1	HOW TO PROGRAM THE INSTRUMENT WITH AN ALREADY PROGRAMMED “HOT KEY” (DOWNLOAD)	13
9.2	HOW TO COPY THE PARAMETER MAP INTO THE “HOT KEY” (UPLOAD).....	13
10	PROGRAMMING USING LOCAL USER INTERFACE	13
10.1	ENTER PARAMETERS PROGRAMMING LEVEL PR1	14
10.2	ENTER PARAMETERS PROGRAMMING LEVEL PR2	14
10.3	ENTER PARAMETERS PROGRAMMING LEVEL PR3	14
11	MENU (MENU KEY)	15
11.1	ALARM LIST: READ AND RESET	15
11.2	ALARM LOG LIST	16
12	REMOTE KEYBOARD V1613	17
13	REMOTE LCD PANEL V21810	17
14	REMOTE TOUCH PANEL VTIC10	18
15	TABLE OF THE OUTPUT STATUS IN ALARM CONDITION	18
15.1	MACHINE ALARMS	18
15.2	CIRCUIT ALARM	21
15.3	COMPRESSOR ALARM	21
15.1	WARNING	22
16	BLACK-OUT	22
17	WIRING CONNECTIONS	23
17.1	IC106CX: HARDWARE RESOURCES	23
17.2	IC108CX: HARDWARE RESOURCES	24
17.1	REMOTE PANEL CONNECTION (V1613 OR V21810)	25
17.2	ANALOG INPUTS NTC – PTC PROBES	27
17.3	DIGITAL INPUTS	28

17.4	ANALOG INPUT FOR PRESSURE TRANSDUCER PP30 (4 ÷ 20MA SIGNAL)	29
17.5	ANALOG INPUT FOR PRESSURE RATIOMETRIC TRANSDUCER PPR30 (0 ÷ 5V SIGNAL) 29	
17.6	PWM OUTPUT FOR CONDENSING FAN SPEED CONTROL	30
17.7	PROPORTIONAL OUTPUT FOR FAN CONDENSING CONTROL OR FOR COMPRESSOR INVERTER CONTROLLED OR FOR AUXILIARY OUTPUTS	31
17.8	PROPORTIONAL OUTPUT 0..10V TO CONTROL DUMPER MOTORS	32
17.9	PROPORTIONAL OUTPUTS CONFIGURED FOR AUX RELAY CONTROL	34
17.10	CONNECTION TO THE ELECTRONIC EXPANSION VALVE DRIVER IEV22D OR IEV12D	35
18	INSTALLING AND MOUNTING	36
18.1	PANEL CUT- OUT	36
18.2	VERTICAL BOARDS VI613 PANEL CUT-OUT	36
19	ELECTRICAL CONNECTIONS	37
20	TECHNICAL DATA	38
20.1	ELECTRICAL SPECIFICATIONS	38
20.2	ANALOGUE INPUTS	38
20.3	DIGITAL INPUT	39
20.4	ANALOGUE OUTPUTS	39
20.5	DIGITAL OUTPUTS	39

1 GENERAL WARNING

1.1 PLEASE READ BEFORE USING THIS MANUAL

- This manual is part of the product and should be kept near the instrument for easy and quick reference.
- The instrument shall not be used for purposes different from those described hereunder. It cannot be used as a safety device.
- Check the application limits before proceeding.
- Dixell Srl reserves the right to change the composition of its products, even without notice, ensuring the same and unchanged functionality.

1.2 SAFETY PRECAUTIONS

- Check the supply voltage is correct before connecting the instrument.
- Do not expose to water or moisture: use the controller only within the operating limits avoiding sudden temperature changes with high atmospheric humidity to prevent formation of condensation
- Warning: disconnect all electrical connections before any kind of maintenance.
- The instrument must not be opened.
- In case of failure or faulty operation send the instrument back to the distributor or to “Dixell S.r.l.” with a detailed description of the fault.
- Consider the maximum current which can be applied to each relay (see Technical Data).
- Ensure that the wires for probes, loads and the power supply are separated and far enough from each other, without crossing or intertwining; do not use the same electrical conduit to install high voltage cabling and low voltage cabling.
- The ground connection of the secondary coil of the transformer that powers the device can result in a bad performance; where possible, this connection should be avoided.
- Fit the probe where it is not accessible by the end user.
- In case of applications in industrial environments, the use of mains filters (our mod. FT1) in parallel with inductive loads could be useful.

- The  symbol alerts the user of non-insulated “dangerous voltage” within the product area that is sufficiently high to constitute a risk of electric shock to persons.

- The  symbol alerts the user of important operating and maintenance (assistance) instructions found in the documentation attached to the device.

➤ ***Separate the power supply of the device from the rest of the electrical devices connected inside the electrical panel.***

- ***The connection to ground of the secondary coil of the transformer that supply the device may generate the malfunctioning of the device; where possible this connection must be avoided.***

1.3 PRODUCT DISPOSAL (WEEE)

With reference to Directive 2002/96/EC of the European Parliament and of the Council of 27 January 2003 and to the relative national legislation, please note that:

- There lies the obligation not to dispose of electrical and electronic waste as municipal waste but to separate the waste.
- Public or private collection points must be used to dispose of the goods in accordance with local laws. Furthermore, at the end of the product's life, it is also possible to return this to the retailer when a new purchase is made.
- This equipment may contain hazardous substances. Improper use or incorrect disposal can have adverse effects on human health and the environment.
- The symbol shown on the product or the package indicates that the product has been placed on the market after 13 August 2005 and must be disposed of as separated waste.
- Should the product be disposed of incorrectly, sanctions may be applied as stipulated in applicable local regulations regarding waste disposal.

2 USING THE QUICK REFERENCE GUIDE

In this guide there are some general guidelines regarding the product; more details are in the full manual, to be requested from the Dixell Customer Service department.

3 IC100 CX TABLE OF THE FEATURES

	IC106CX	IC108CX
RELAYS		
6	●	
8		●
DIGITAL INPUTS		
11 (free of voltage)	Configurable	Configurable
ANALOG INPUTS		
4 (NTC or PTC or Digital input) 2 (NTC or PTC or 4÷20mA or 0 ÷ 5Volt or Digital input)	Configurable	Configurable
PROPORTIONAL OUTPUTS		
2 (signal 0÷10V)	Configurable	Configurable
2 (signal 0÷10V or PWM*) * only for condenser fan control, to connect to XV __PK series)	Configurable	Configurable
SERIAL OUTPUTS		
TTL (Mod-BusRtu protocol)	●	●
Remote panel V1613 (up to 2 remote keyboards) or one V21810 (LCD panel) or one VTIC10 (Touch panel)	●	●
LAN (to connect an IEV electronic expansion valve driver)	●	●
POWER SUPPLY		
12 Vac/dc (+15%; -10%)	●	●
24 Vac/dc (± 10%)	Opt	Opt
OTHER		
Clock on board	Opt	Opt
Buzzer	Opt	Opt



- Opt = optional
- ● = default



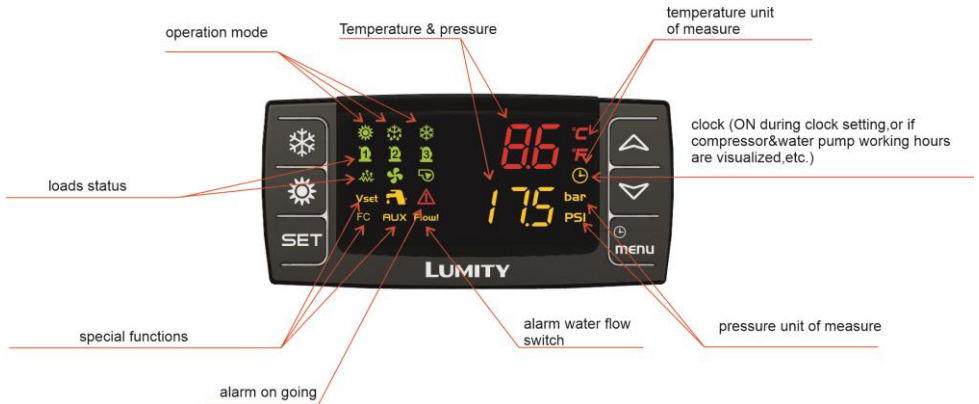



4 USER INTERFACE

4.1 MEANING OF THE LEDS



4.2 DISPLAY AND ICONS

ICON	MEANING / FUNCTIONNING
°C °F BAR PSI	Lighted when the display shows a temperature or pressure
	Lighted when the bottom display shows the clock Lighted during the programming parameters if it is time based Lighted in function menu when the display shows the defrost delay
	Alarm: blinking in case of alarm
	Lighted when sanitary hot water function is active
menu	Lighted after pressing menu button

	Lighted if anti freeze heaters/ integration heating / boiler are activated
Flow!	Flow switch alarm / supply fan overload (air / air unit)
	Water pump: lighted if at least one pump is ON
	Condenser fan: lighted if at least one fan is ON
	Lighted when a compressor is ON Blinking = when the delay of activation is running
AUX	Lighted when auxiliary function is active
	Lighted when the controller is ON in cooling or heating
FC	Lighted when the Free cooling is active
	Lighted when the defrost is activated Blinking when the delay to activate the defrost is active

5 DISPLAY LAYOUT

Pressing Up or Down button the display shows the temperature or pressure of the main probes configured in the instrument.

The lower display shows the label of the selected probe while the upper display shows its value.



6 OTHER DISPLAY INFORMATION

6.1 READ THE SET POINT VALUE

Press and release the SET key:

If the unit is on standby:

- lower display shows SETc (set chiller);
- press SET key again, lower display shows SEtH (set heat pump, if it is enabled);
- press SET key again, lower display shows SEtr (set real of operation, in the case where the Energy Saving and / or function dynamic set point are active);
- press SET key again, lower display shows SEtS (set sanitary circuit, in case it is enabled)

If the instrument is in chiller operation:

- lower display shows SETc (set chiller);
- press SET key again, lower display shows SEtr (set real of operation, in the case where the Energy Saving and / or function dynamic set point are active);
- press SET key again, lower display shows SEtS (set sanitary circuit, in case it is enabled)







If the instrument is in chiller operation:

- lower display shows SEtH (set heat pump);
- press SET key again, lower display shows SEtr (set real of operation, in the case where the Energy Saving and / or function dynamic set point are active);
- press SET key again, lower display shows SEtS (set sanitary circuit, in case it is enabled)







6.2 MODIFY THE SET POINT

- push **SET** key for at least **3** seconds
- use the **UP** or **DOWN** key to modify the setpoint. In chiller mode it is possible to modify the chiller set point, in heat pump it is possible to modify the heat pump set point, in std-by it is possible to modify both the set point.
- push **SET** to confirm or wait the timeout (15seconds).

7 KEY FUNCTION

KEY	ACTION	FUNCTION
	Push and release	Show chiller set point SetC , heat pump set point SetH , sanitay water set point SetS
	Push once again	In chiller or heat pump if the Energy saving or the Dynamic setpoint are enabled it shows the real setpoint Setr .
	Push for 3 seconds	Allows to modify the set point
	During the programming: push once	To enter parameter modification or confirm a value
	Push when an alarm is showed in menù ALrM	To reset the alarm
	Push once	To read probes value
	Pushing once during the programming	To change the group of parameters, to change the parameter, to change the value of the parameter
	Push for 1 second during the programming when the display visualizes Pr1 or Pr2 or Pr3	1 time shows the Pr2 programming level 2 times shows the Pr3 programming level
	Push once	To read probes value
	Pushing once during the programming	To change the group of parameters, to change the parameter, to change the value of the parameter
	Push once	To turn ON or turn OFF the controller (in chiller or heat pump depending from CF59 parameter)
	Push once	To turn ON or turn OFF the controller (in chiller or heat pump depending from CF59 parameter)
	Push once	To enter the function Menu
	Push for 3 seconds	To set the clock (only for controller with clock on board)
	Pushing once during the programming	To exit from a group of parameters

7.1 KEY COMBINANTION

KEY	ACTION	FUNCTION
 + 	Push for 3 seconds together	Enter the programming parameters
	Only in Pr3 level: push SET and DOWN key	Select the parameter level visibility Pr1 / Pr2 / Pr3
 + 	Push once together	Exit the programming parameters
	Push 5 seconds in heat pump mode	Manual defrost
 + 	Only in Pr3 programming level: push SET and then the MENU key	In Pr3 defines if the parameter can be modified or not in the other levels.

8 FIRST INSTALLING

8.1 ON BOARD CLOCK (OPTIONAL)

In case of power failure the time and date are maintained for about 3 days (at room temperature 25 °C); the display shows the message "rtC" and it is necessary to set the clock.

8.2 RTC SETUP

1. Push **Menu** key continuously for 3 seconds until the bottom display shows "**Hour**" and the top display shows its value.
2. Push **SET** one time: the value is blinking.
3. Use the Up and Down keys to adjust it. Push **SET** one time to confirm.
4. Push up or down keys and repeat the operations 2. 3. and 4. for all the RTC parameters:
 - **Min**: minutes (0÷60)
 - **UdAy**: day of the week (**Sun** = Sunday, **Mon** =Monday, **tuE** =Tuesday, **UEd** = Wednesday, **thU** = Thursday, **Fri** =Friday, **SAt** =Saturday)
 - **dAy**: day of the month (0÷31)
 - **Mnth**: month (1÷12)
 - **yEAR**: year (00÷99)

9 PARAMETERS PROGRAMMING WITH THE “HOT KEY 64”

9.1 HOW TO PROGRAM THE INSTRUMENT WITH AN ALREADY PROGRAMMED “HOT KEY” (DOWNLOAD)

1. Power off the instrument
2. Insert the hot key already programmed (by software Wizmate or other instrument)
3. Power on the instrument
4. Automatically the parameters are downloaded

During the download the regulation is locked and the top display shows the “doL” blinking label. At the end of the download will appear:

- “End” if the programming procedure is completely OK, after 30seconds the regulation starts automatically.
- “Err” if the programming procedure has found an error and the parameter have not been transferred. In this case turn off and then on the instrument supply to repeat the operation or remove the hot key, with power supply off, to restart the regulation.

9.2 HOW TO COPY THE PARAMETER MAP INTO THE “HOT KEY” (UPLOAD)

- Power on the instrument
- Insert the hot key
- Enter the function Menu
- Select the UPL function (on the bottom display)
- Push SET key and immediately the instrument starts transfer the parameters into the Hot key.

During the upload the regulation is locked and the top display shows the “UPL” blinking label. At the end of the UPLoad will appear:

1. “End” if the programming procedure is completely OK, after 30seconds the regulation starts automatically.
2. “Err” if the programming procedure has found an error and the parameter have not been transferred. Repeat the procedure.

To exit the UPL function push the MENU key or wait the time-out (15 sec).

10 PROGRAMMING USING LOCAL USER INTERFACE

Though the keyboard it is possible to modify the values of the parameters and set for each one of them the visibility and editability; each parameter can be made visible at different levels of users:

- Pr1 User level (default Password = 1)
- Pr2 Maintenance level (default Password = 2)
- Pr3 OEM level (default Password = 3)

The default password for resetting the alarm history and compressor overload alarm is 4.

Passwords can be customized using specific parameters; in the case in which it is necessary to access the parameters and the passwords have been changed, it is necessary to contact the machine manufacturer to obtain the necessary information.

10.1 ENTER PARAMETERS PROGRAMMING LEVEL PR1

Enter the Pr1 “User level”:

1. Push **SET + DOWN** keys together for 3 seconds. The top display shows “PAS” and the bottom display shows “Pr1”.
2. Push **SET** key and the top display shows “0” blinking
3. Push **UP** or **DOWN** to select Pr1 password
4. Push **SET** and, if the value is correct, the top display shows the first family of parameters “**ALL**”
5. Push **UP** or **DOWN** to select the parameter family
6. Push **SET** to enter; the bottom display shows the first available parameter while the top display shows its value.
7. Push **UP** or **DOWN** to modify its value
8. Push **SET** to confirm the new value
9. If necessary, modify others parameter
10. Push **SET + UP** keys together to exit parameters programming

10.2 ENTER PARAMETERS PROGRAMMING LEVEL PR2

Enter the Pr2 “service level”:

1. Push **SET + DOWN** keys together for 3 seconds. The top display shows “PAS” and the bottom display shows “Pr1”
2. Push **UP** key for 2 seconds and the top display will show Pr2
3. Push **SET** key and the top display shows “0” blinking
4. Push **UP** or **DOWN** to select Pr2 password
5. Push **SET** and, if the value is correct, the top display shows the first family of parameters “**ALL**”
6. Push **UP** or **DOWN** to select the parameter family
7. Push **SET** to enter, the bottom display shows the first available parameter label while the top display shows its value
8. Push **UP** or **DOWN** to modify its value
9. Push **SET** to confirm the new value
10. If necessary, modify others parameter
11. Push **SET + UP** keys together to exit parameters programming

10.3 ENTER PARAMETERS PROGRAMMING LEVEL PR3

Enter Pr3 “OEM level”:

1. Push **SET + DOWN** keys together for 3 seconds. The top display shows PAS and the bottom display shows Pr1
2. Push **UP** key for 2 seconds and the top display shows Pr2
3. Push **UP** key again for 2 seconds and the top display will show Pr3
4. Push **SET** key and the top display shows “0” blinking
5. Push **UP** or **DOWN** to select Pr3 password
6. Push **SET** and, if the value is correct, the top display shows the first family of parameters “**ALL**”

7. Push **UP** or **DOWN** to select the parameter family
8. Push **SET** to enter; the bottom display shows the first available parameter label while the top display shows its value
9. Push **UP** or **DOWN** to modify its value
10. Push **SET** to confirm the new value
11. If necessary, modify others parameter
12. Push **SET + UP** keys together to exit parameters programming

11 MENU (MENU KEY)

Enter the menu:

- press the menu button;
- press the UP or DOWN button to select the submenu;
- press the SET to enter the submenu.

Exit menu functions:

- Press the menu button or wait the time-out.

Entering the menu, it is possible to:

- **ALrM** Read and reset the alarms
- **ALOG** Read and reset the alarm log
- **UPL** Upload the parameter into the Hot Key
- **CrEn** Enable – disable one or the two circuits
- **COEn** Enable – disable one of the compressors
- **Hour** Read and reset the number of compressor running hour
- **COSn** Read and reset the number of compressor starts-up
- **COdt** Read the compressor discharge temperature
- **Cond** Read the condensing fan speed percentage of the proportional output
- **Pout** Read the percentage of the proportional output 0 ÷ 10 Vdc
- **PoEn** Enable – disable evaporator or condenser water pumps
- **dF** Time counting to next defrost cycle, under heat pump mode,
- **uS** Read the probe temperatures that enabled to control the auxiliary output
- **SoL** Read temperature, Set point and output status of solar panel
- **FC** Read temperature, Set point and output status of Free cooling
- **trEM** Read probe temperature of the remote panels
- **Et1** Read temperature, pressure, set point of the electronic expansion valve 1
- **Et2** Read temperature, pressure, set point of the electronic expansion valve 2
- **REC** Enable / disable recovery function

11.1 ALARM LIST: READ AND RESET

ALrM FUNCTION

1. Push MENU key
2. The display shows ALrM label
3. Push **SET** key (Nothing happens if there are not alarms)

4. The bottom display shows the alarm code and the top display shows the label **rSt**, if it is possible to reset the alarm, or **NO** if it is not possible to reset the alarm
5. Push **UP** or **DOWN** to scroll the alarm list (if more than one alarm is active)
6. Repeat the reset procedure for each alarm
7. To exit the ALrM reset, push **MENU** or wait the timeout.

11.2 ALARM LOG LIST

ALOG FUNCTION

1. Push **MENU** key
2. Push **UP** or **DOWN** to select ALOG
3. Push **SET** key
4. The bottom display shows the alarm label, the top display shows a number in the range 00 to 99.
5. Use the **UP** or **DOWN** keys to scroll the list.
6. To exit the ALOG function push **MENU** or wait the timeout.

Erase the Alarm log list

1. Push **MENU** key
2. Push **UP** or **DOWN** to select ALOG
3. Push the **SET** key
4. Push **UP** or **DOWN** keys and search the **ArSt** label on the bottom display; the top display shows PAS.
5. Push **SET**; the bottom display shows **PAS** and the top display shows "0" blinking
6. Push **UP** or **DOWN** to set the password
7. If the password is OK the label **ArST** blinks for 5 seconds then the display returns to normal condition read-out
8. If the password is not correct the display shows **PAS** again
9. To exit, push the **MENU** key or wait the timeout.

The standard password to reset the alarm log is "4".

12 REMOTE KEYBOARD VI613

The display visualization and the button functions are the same of the I chill, then refer to previous chapters of the quick reference guide.



13 REMOTE LCD PANEL V2I810

The description of the user interface is available in the user manual of the Visograph.



14 REMOTE TOUCH PANEL VTIC10

The description of the user interface is available in the user manual of the Visotouch.



15 TABLE OF THE OUTPUT STATUS IN ALARM CONDITION

15.1 MACHINE ALARMS

Alarm Code	Alarm description	Comp.	Heaters	Support heaters (air/air unit)	Evaporator Pump / Supply fan	Condenser Pump	Domestic hot water Water pump	Solar panel Water pump	Condenser fan	Auxiliary relay
ACF1 ... AC16	Configuration alarm	OFF	OFF	OFF	OFF	OFF	OFF	OFF	OFF	OFF
ACFL	Condenser flow alarm	OFF (4)	(8)	(8)	(8)	OFF (3)	(8)	(8)	(8)	(8)
AEE	Eeprom alarm	OFF	OFF	OFF	OFF	OFF	OFF	OFF	OFF	OFF
AEFL	Evaporator flow alarm	OFF (4)	OFF (boiler)	(8)	OFF (3)	(8)	(8)	(8)	(8)	(8)
AEht	High inlet evaporator water temperature	OFF	OFF (boiler)	(8)	(8)	(8)	(8)	(8)	(8)	(8)
AHFL	Domestic hot water flow switch alarm	OFF (6)	(8)	(8)	(8)	OFF	OFF	(8)	(8)	(8)

ALC1	General alarm	OFF	OFF	OFF	OFF	OFF	OFF	OFF	OFF	
ALC2	General alarm type 2	OFF (9)	OFF (9)	OFF (9)	OFF (9)	OFF (9)	OFF (9)	OFF (9)	OFF (9)	OFF (9)
ALSF	Phase sequence alarm	OFF	OFF	OFF	OFF	OFF	OFF	OFF	OFF	OFF
ALti	Low air temperature of the evaporator inlet (air / air unit) Alarm									
AP1 ... AP6	Probe alarm	(1)	(1)	(1)	(1)	(1)	(1)	(1)	(1)	(1)
APE1 ... APE8	I/O Expansion probe alarm	(1)	(1)	(1)	(1)	(1)	(1)	(1)	(1)	(1)
APFL	Solar panel flow switch alarm	OFF (6)	(8)	(8)	(8)	(8)	(8)	OFF	(8)	(8)
APr1 APr2	Remote keyboard probe alarm	OFF (3)	OFF (3)	OFF (3)	OFF (3)	OFF (3)	OFF (3)	OFF (3)	OFF (3)	OFF (3)
APU1 ... APU4	IEV Electronic Expansion Valve probe alarm	(7)	(7)	(7)	(7)	(7)	(7)	(7)	(7)	
ASLA	Serial communication failure with I/O expansion	OFF	OFF	OFF	OFF	OFF	OFF	OFF	OFF	
AtAS	Domestic hot water pump overload	OFF (6)			(8)	(8)	(8)	(8)	(8)	(8)
AtC1	Condenser 1 water pump overload alarm	OFF (4)	(8)	(8)	(8)	OFF	(8)	(8)	OFF	(8)
AtC2	Condenser 2 water pump overload alarm	OFF (4)	(8)	(8)	(8)	OFF	(8)	(8)	OFF	(8)
AtE1	Evaporator 1 water pump overload alarm	OFF (4)	OFF (boiler) (5)	(8)	OFF	(8)	(8)	(8)	OFF	(8)
AtE2	Evaporator 2 water pump overload alarm	OFF (4)	OFF (boiler) (5)	(8)	OFF	(8)	(8)	(8)	OFF	(8)
AtHS	Domestic hot water heaters overload					(8)				
AtSF	Fan supply overload alarm	OFF		OFF	OFF				(8)	(8)

AUAL	Serial communication failure with IEV expansion valve driver	OFF	OFF	OFF	OFF	OFF	OFF	OFF	OFF	
AtrE	Remote terminal Visograph 2.0 communication alarm	(1)	(1)	(1)	(1)	(1)	(1)	(1)	(1)	(1)
Atr1 Atr2	Remote terminal VI622 / TI620 communication alarm	(1)	(1)	(1)	(1)	(1)	(1)	(1)	(1)	(1)

- (1) = the status of the load depends on which probe is faulty; e.g. if the regulation probe is faulty main loads are OFF, if external temperature probe is faulty there is no direct action on the loads but the dynamic set point function is disabled
- (2) = with probe configured as auxiliary relay control
- (3) = loads are OFF only if the probe of the remote keyboard is set as regulation probe
- (4) = The compressors are Off if the water pump is the only configured water pump; if 2 water pumps are configured, the compressors are OFF if both water pumps are in alarm or not available
- (5) = Boiler heaters off if the water pump is the only configured water pump; if 2 water pumps are configured, the compressors are OFF if both water pumps are in alarm or not available
- (6) Compressors switched off if only production of domestic hot water is ongoing
- (7) In case of electronic expansion valve alarm all loads are OFF
- (8) These loads are not influenced directly by the alarm; their status depends on the configuration of the device
- (9) If A050=0 it is only a warning and the loads are not involved, if A050=1 it is a real alarm and the loads are switched OFF

15.2 CIRCUIT ALARM

Alarm Code	Alarm description	Compressors	Fan condensing
b1AC	Anti-freeze alarm in chiller mode	OFF	OFF
b1Ac	Anti-freeze warning in chiller		
b1AH	Anti-freeze alarm in heat pump	OFF	OFF
b1Ah	Anti-freeze warning in heat pump		
b1dF	End defrost alarm		
b1HP	High pressure switch	OFF	OFF after 60 seconds
b1hP	High condenser pressure by pressure transducer	OFF	OFF after 60 seconds
b1hP	High condensing temperature	OFF	OFF after 60 seconds
b1LP	Low pressure switch	OFF	OFF
b1LP	Low pressure detected by evaporating pressure transducer or by high pressure transducer (if only one pressure transducer is configured)	OFF	OFF
b1IP	Low condenser temperature	OFF	OFF
b1PH	Pump down alarm during the switching off the compressor	OFF	OFF
b1PL	Pump down during the switching on the compressor	OFF	OFF
b1tF	Fan overload	OFF	OFF
b1UA	Expansion valve 1 or valve 2 alarm	OFF	OFF

15.3 COMPRESSOR ALARM

Alarm Code	Alarm description	Compressor (n)	Compressors not involved
C(n)dS	Compressor (n) disabled (by dedicated procedure in menu function)	OFF	
C(n)dt	Compressor (n) high discharge temperature	OFF	
C(n)HP	Compressor(n) high pressure switch	OFF	
C(n)oP	Compressor(n) oil pressure switch / Oil level switch	OFF	
C1Pd	Compressor oil differential	OFF	
C(n)tr	Compressor(n) overload	OFF	OFF if is enabled by parameter the switching OFF of all compressors

15.1 WARNING

Alarm Code	Alarm description
AEP1	Evaporator 1 water pump maintenance
AEP2	Evaporator 2 water pump maintenance
ACP1	Condenser 1 water pump maintenance
ACP2	Condenser 2 water pump maintenance
AEun	Unloading by high evaporator inlet temperature
ASAn	Domestic hot water pump maintenance
ASUn	Solar panel water pump maintenance
ArtC	Clock to be set (the device if not powered for some days loses the time and the date)
ArtF	Clock failure
C(n)Mn	Compressor (n) maintenance
b1Cu	Unloading by high or low evaporator or condenser temperature or pressure
b1Cu	Unloading by low evaporator temperature or pressure
b1rC	Recovery function disabled
b1Eu	Unloading by low evaporator outlet temperature
noL	Link problem between the IChill and the remote keyboard

16 BLACK-OUT

After the black-out, when the power supply is restored:

1. the instrument restores the same operating mode lost after the supply failure.
2. if active at the power off, the defrost is aborted
3. All the timers are reloaded
4. The alarm, if active in manual mode at the power down, is not reset

17 WIRING CONNECTIONS

17.1 IC106CX: HARDWARE RESOURCES

- 6 digital outputs (relays):
max current on the relay contacts relè 5(2)A 250V
max current on the common line 10A 250V
- 11 digital inputs free of voltage
- analogue inputs:
 - 4 temperature probes (NTC / PTC)
 - 2 temperature probes (NTC / PTC) / pressure transducer 4÷20 mA / pressure transducer ratio-metric 0÷ 5.0 Volt
- 4 modulating outputs:
 - 2 (0 ÷ 10 Volt)
 - 2 (0 ÷ 10.0 Volt or PWM*) (*for modulating condenser fan)
- 1 output to connect the remote panel (max 2 VI613 remote keyboards or 1 Visograph or 1 Visotouch)
- 1 LAN to connect an IEV electronic expansion valve driver
- 1 TTL output to connect:
 - Hot key 64 for parameters programming
 - XJ485CX (interface to convert TTL signal to RS485 signal) for monitoring systems (XWEB or third-party system)

C_{1R} = common line for RL1, RL2, RL3, RL4 C_{2R} = common line for RL5, RL6

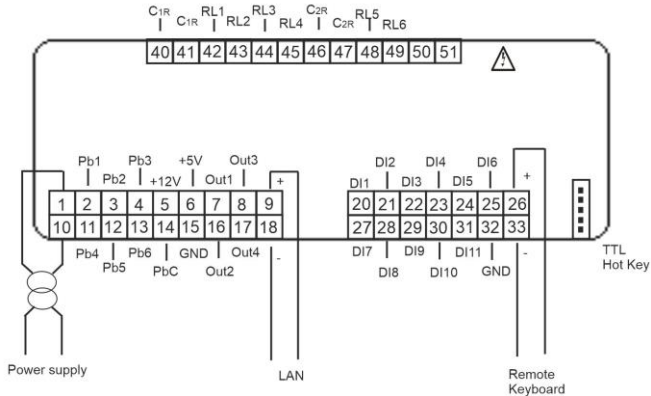

17.2 IC108CX: HARDWARE RESOURCES

- 8 digital outputs (relays):
max current on the relay contacts relè 5(2)A 250V
max current on the common line 10A 250V
- 11 digital inputs: (free of voltage)
- analogue inputs:
 - 4 temperature probes (NTC / PTC)
 - 2 temperature probes (NTC / PTC) / pressure transducer 4÷20 mA / pressure transducer ratio-metric 0÷ 5.0 Volt
- 4 modulating outputs:
 - 2 (0 ÷ 10 Volt)
 - 2 (0 ÷ 10.0 Volt or PWM*) (*for modulating condenser fan)
- 1 output to connect a remote panel (max 2 VI613 remote keyboards or 1 Visograph or 1 Visotouch)
- 1 LAN to connect an IEV electronic expansion valve driver
- 1 TTL output to connect:
 - Hot key 64 for parameters programming
 - XJ485CX (interface to convert TTL signal to RS485 signal) for monitoring systems (XWEB or third-party system)

C_{1R} = common line for RL1, RL2, RL3, RL4

C_{2R} = common line for RL5, RL6, RL7, RL8

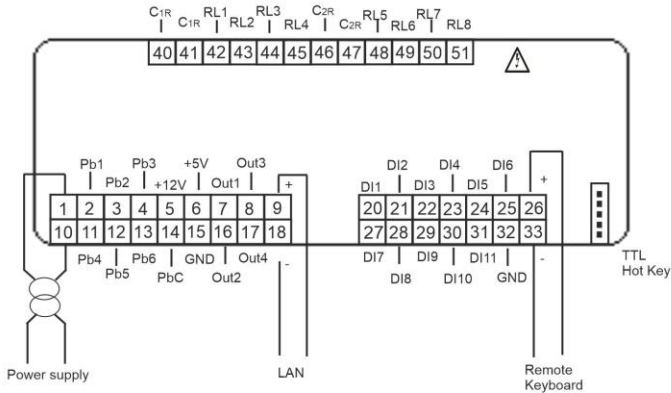

17.1 REMOTE PANEL CONNECTION (VI613 OR V2I810)

It is possible to connect to the instrument up to two remote panels VI613 available with or without temperature sensor on board, or a V2I810 LCD panel, or a touch panel VTIC10; the use of keyboards VI613 exclude the possibility of using the keyboard Visograph or Visotouch and vice versa.

Parameters CF55 and CF56 allow to enable the keyboards VI613; the parameter CF74 allows to enable the V2I810 keyboard or VTIC10.

If the remote terminal VI613 is provided with probe on board, the temperature adjustment can be performed with the probe of the terminal.

The connection of the remote terminals must be performed using a shielded / twisted cable (such as Belden 8772, wires 1 mm² minimum); the maximum length of VI613 terminal cable is 100 mt. (maximum length of the connection, both if using one or two keyboards), the maximum length of V2I810 or VTIC10 terminal cable is 60mt.

In case of lack of communication between the device and the keyboard (wrong connection, wrong parameters configuration), the display shows the message "noL" (no link).

When using two keyboards VI613 you must configure the dip switch on the rear of the same, giving the first keypad address 1 and 2 to the second keypad.

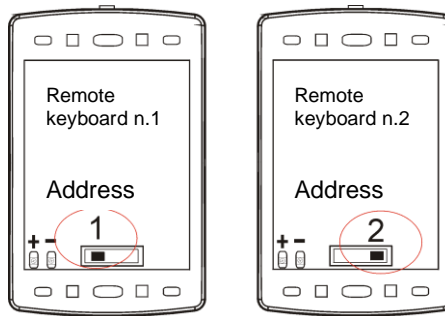

VI613 LED panel

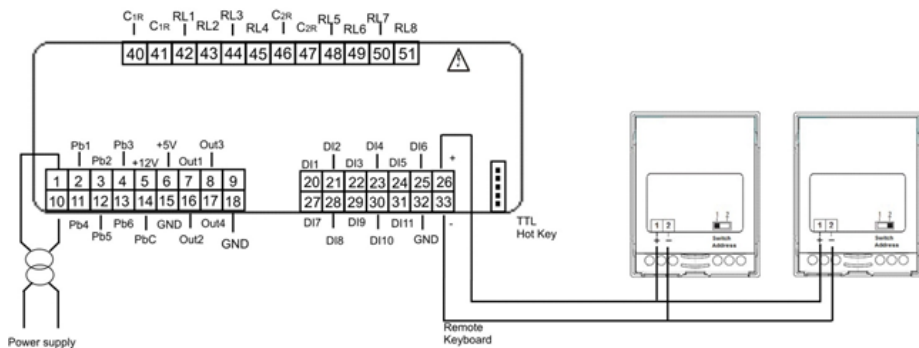

V2I810 LCD PANEL

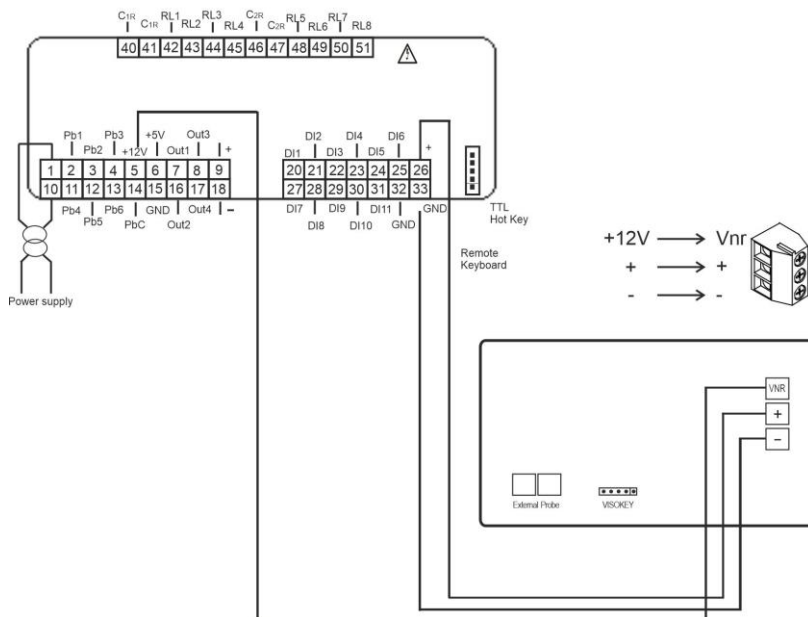

VTIC10 TOUCH PANEL

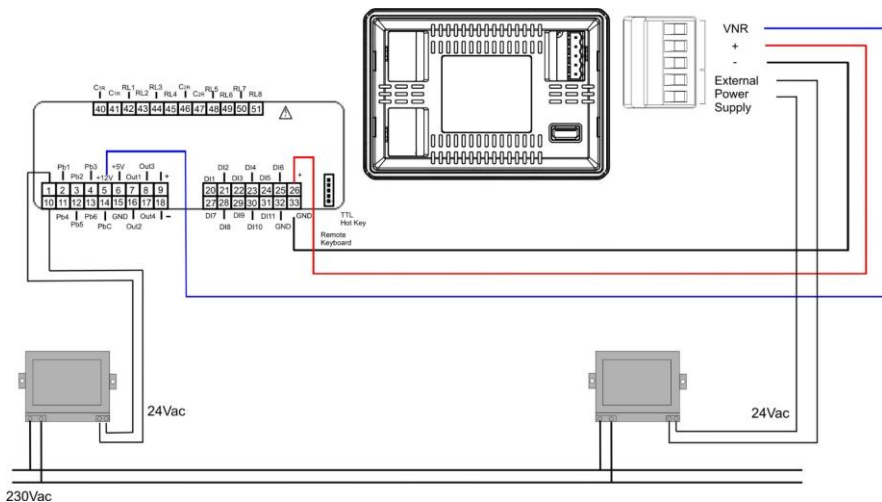

17.2 ANALOG INPUTS NTC – PTC PROBES

PbC = common terminal

Pb1...Pb6 = probe inputs

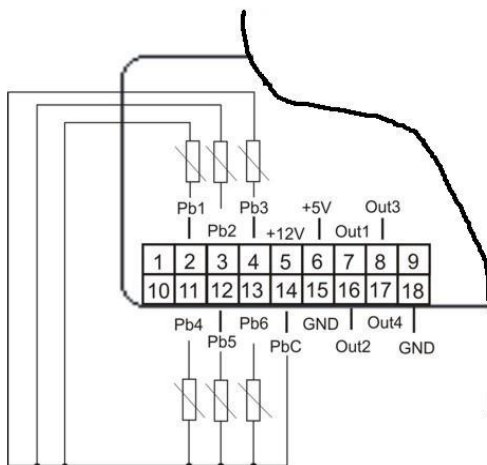

17.3 DIGITAL INPUTS

GND = common terminal

ID1...ID11 = digital inputs

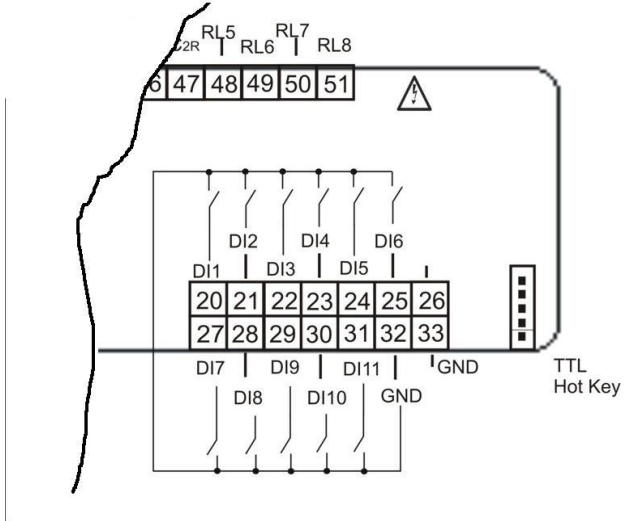

17.4 ANALOG INPUT FOR PRESSURE TRANSDUCER PP30 (4 ÷ 20MA SIGNAL)

12V = power supply for pressure transducers
 Pb3 and Pb4 = pressure transducer inputs

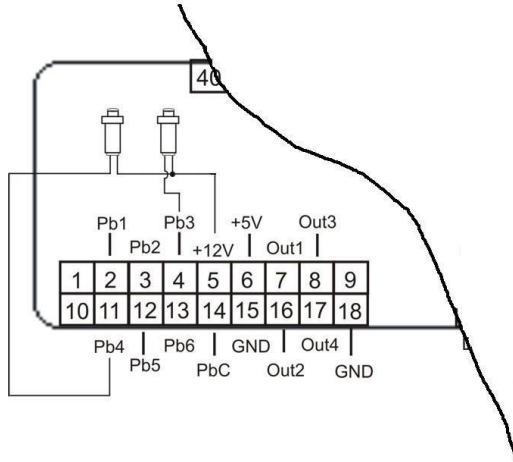

17.5 ANALOG INPUT FOR PRESSURE RATIO METRIC TRANSDUCER PPR30 (0 ÷ 5V SIGNAL)

+5V = power supply for pressure transducers
 GND = ground for pressure transducers
 Pb3 and Pb4 = pressure transducer inputs

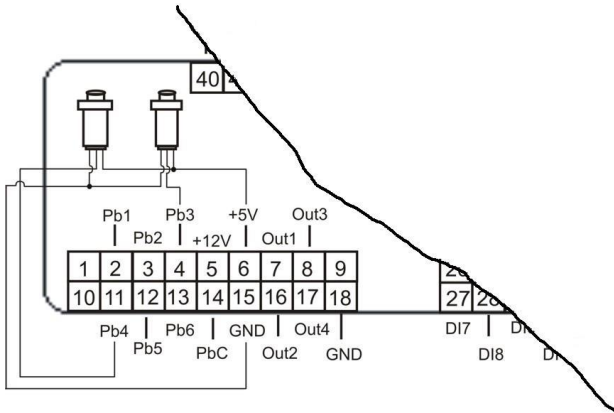

17.6 PWM OUTPUT FOR CONDENSING FAN SPEED CONTROL

OUT3 and OUT4 = signals for the modulation of the condenser fan

GND = ground for pressure transducers

The compatible modules are the following:

XV05PK mono-phase 500 Watt (2A)

XV10PK mono-phase 1000 Watt (4A)

XV22PK mono-phase 2200 Watt (9A)

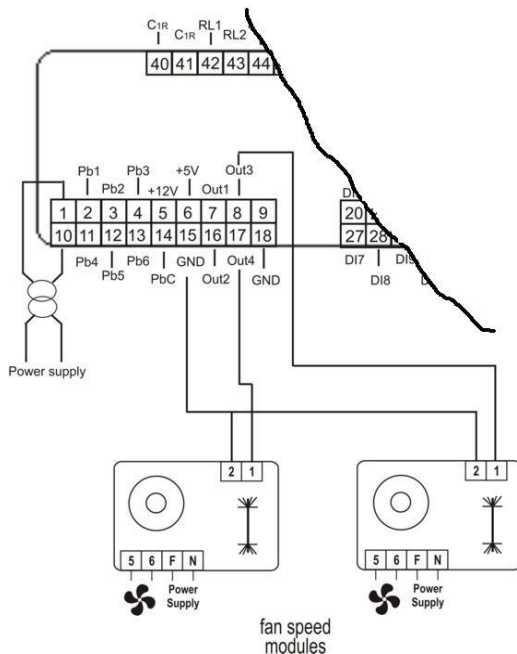

17.7 PROPORTIONAL OUTPUT FOR FAN CONDENSING CONTROL OR FOR COMPRESSOR INVERTER CONTROLLED OR FOR AUXILIARY OUTPUTS

OUT1...OUT4 = signals for the modulation of the condenser fan
 GND = ground for pressure transducers

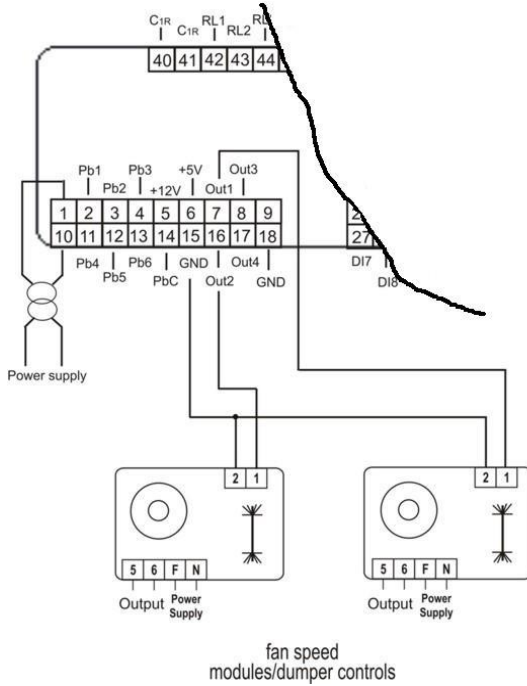

17.8 PROPORTIONAL OUTPUT 0..10V TO CONTROL DUMPER MOTORS

OUT1...OUT4 = signals for the modulation of the dumper motor

GND = ground

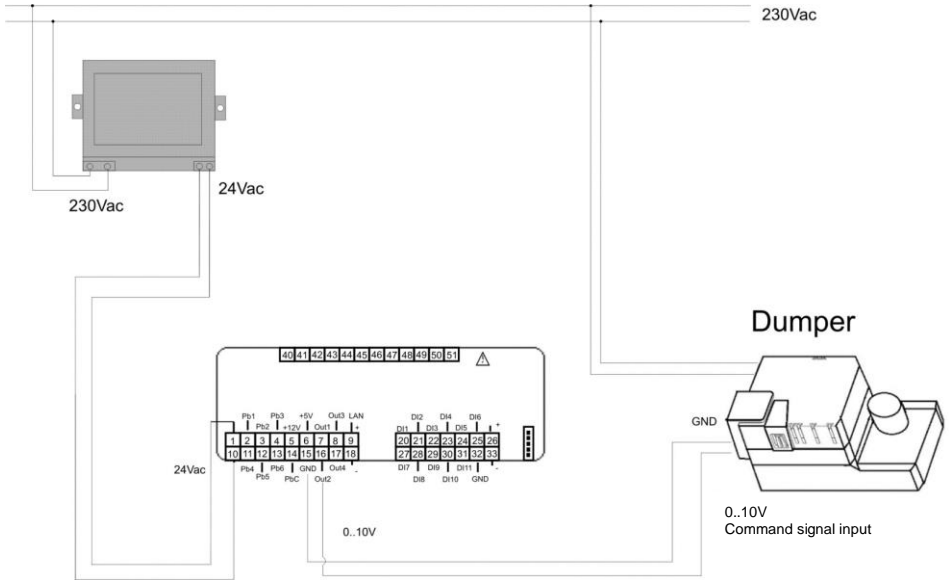

If the dumper motor has a common line between a pole of the power supply and the “-” pole of the 0..10V signal, it is necessary to use two transformers for the power supply of the controller Ichill and the power supply of the dumper motor.

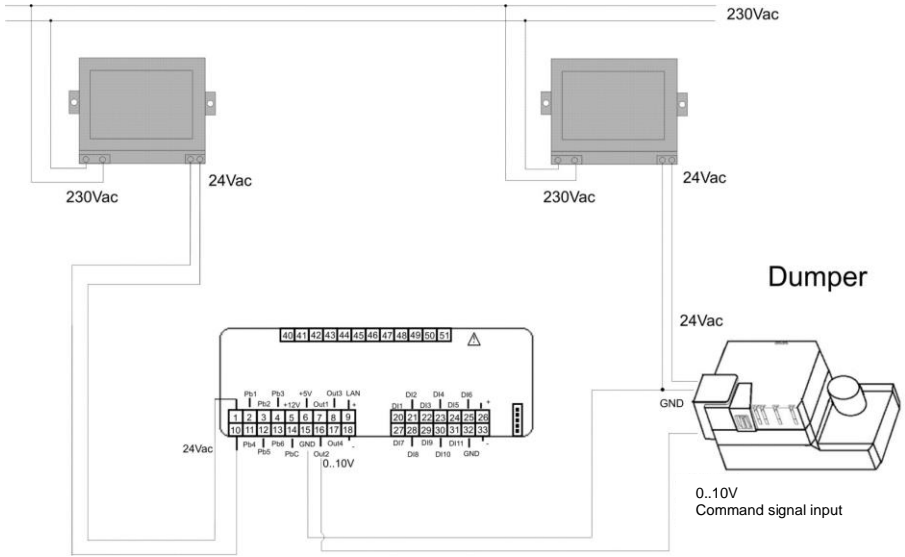

17.9 PROPORTIONAL OUTPUTS CONFIGURED FOR AUX RELAY CONTROL

OUT1...OUT4 = signals for relays
 GND = ground

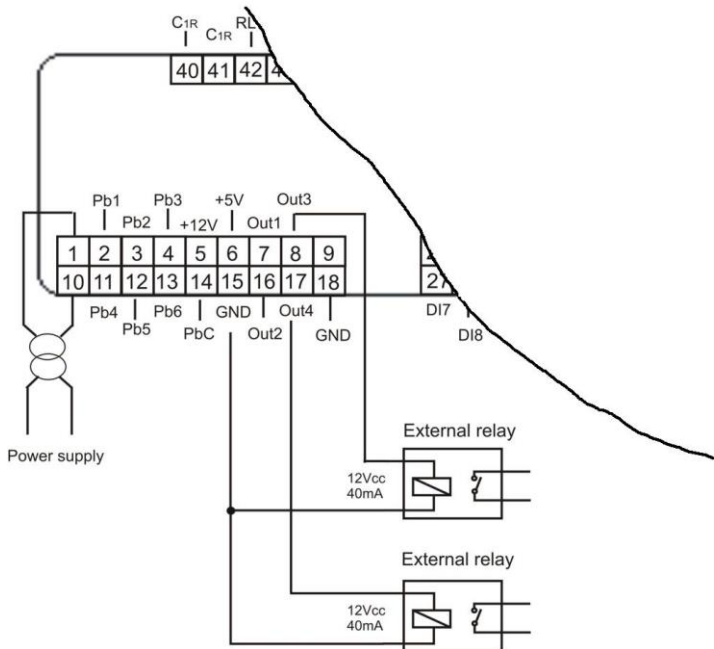

17.10 CONNECTION TO THE ELECTRONIC EXPANSION VALVE DRIVER IEV22D OR IEV12D

The Ichill 100CX EVO can be connected to an Electronic expansion valve driver IEV22D or IEV12D through LAN connection.

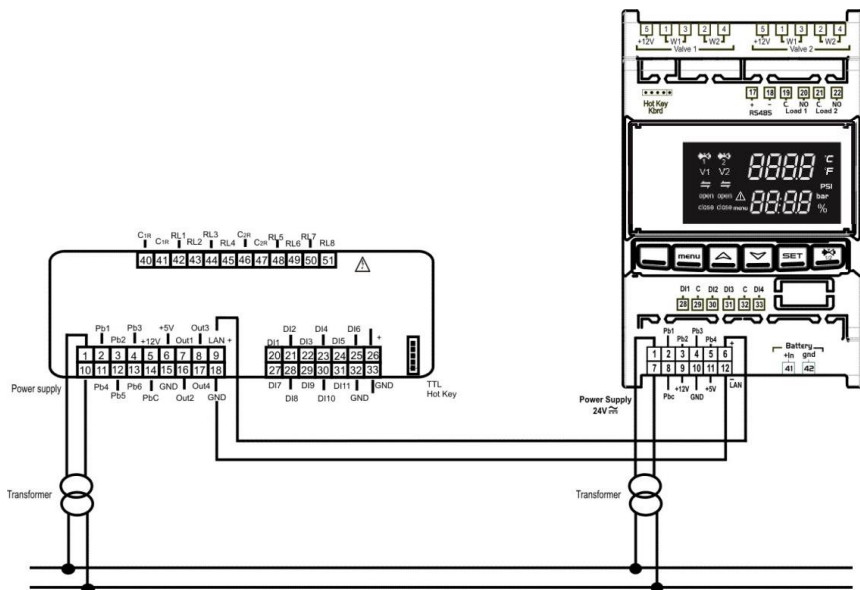

18 INSTALLING AND MOUNTING

18.1 PANEL CUT- OUT

The instrument must be mounted on vertical panel with cut-out 71x29mm, and fixed using the special supplied bracket.

Avoid locations subject to heavy vibration, corrosive gases or excessive dirt. Ensure ventilation around the instrument.

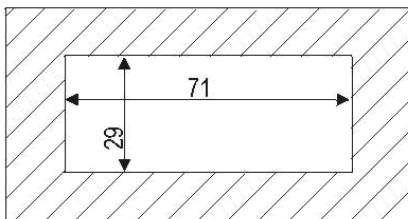

18.2 VERTICAL BOARDS VI613 PANEL CUT-OUT

The keyboard must be mounted on vertical panel with cut-out 72x56 mm, and screwed with two screws. The IP65 can be reached with the gasket RGW-V (optional).

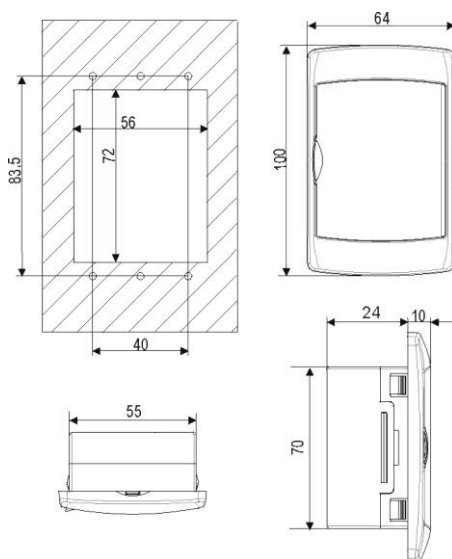

WALL MOUNTING: use the vertical V-KIT (black, white and grey) as described in the following scheme:

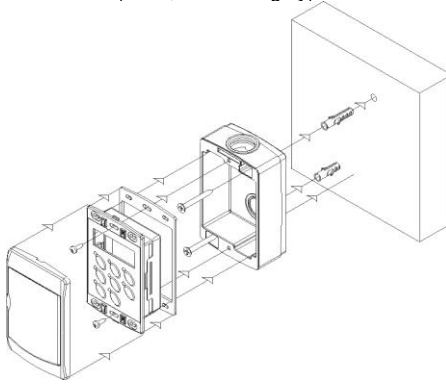

19 ELECTRICAL CONNECTIONS

The instrument is provided with:

- 2 removable terminal blocks MOLEX MICROFIT 14 and 18 ways for power supply / digital and analogue inputs and modulating outputs
- 1 removable terminal blocks AMP 12 ways for the relay outputs
- 5 ways connector for TTL RS485 interface outputs.

Wire size:

- signal cable AWG 24
- power supply cable AWG 22
- relay output AWG 17

General notes:

- Keep low voltage cables, such as analogue/digital inputs/outputs and probes, away from power cables.
- Respect the minimum load current of each relay output, in case of power loads use filtered contactors.

20 TECHNICAL DATA

20.1 ELECTRICAL SPECIFICATIONS

Housing:	Self-extinguishing PC-ABS Thermoplastic
Dimensions:	Frontal panel 32x74mm; depth 60mm
Mounting device:	Panel mounting in a 29x71mm panel cut-out
Resistance to heat:	V0 (UL94)
Degree of protection:	IP65 - Type 1 enclosure
Power Supply:	12Vac/dc -10% ÷ 15%, 50/60Hz, or 24Vac/dc -10% ÷ 10%, 50/60Hz
Rated power:	Max. 10VA
Rated impulse Voltage:	4000V
Overvoltage category:	II
Comparative Tracking Index (CTI):	300V
Type of action:	1B
Pollution Degree:	2
Ambient operating temperature and Humidity:	-10°C ÷ 55°C / 20% ÷ 85% (not condensing)
Shipping and storage temperature:	-40°C ÷ 85°C
Connectors:	Molex connectors for power supply, probes connection, digital inputs, analog outputs) STELVIO screw connectors for LAN connection STELVIO screw connectors for relay
Maximum ampacity:	12A Plug-in terminal block, 14A other types
Purpose of control:	Operating control
Construction of control:	Incorporated control, intended to be used in Class I or Class II equipment

20.2 ANALOGUE INPUTS

Number of inputs:	4 (NTC, PTC, Digital input) 2 (NTC, PTC, 4..20mA, 0..5V, Digital input)
Type of analogue input: (configurable via software parameter)	NTC (-50T110°C; 10KΩ±1% a 25°C) PTC (-50T150°C; 990Ω±1% a 25°C) Ratiometric: 0.5..4.5V Current: 4..20mA Digital input (free contact)
Operation range:	-50°C ÷ 110°C (-58 °F ÷ 230°F) NTC probe

	-50°C ÷ 150°C (-58 °F ÷ 302°F) PTC probe 0 bar ÷ 50 bar (0 psi ÷ 302 psi) pressure probe
Resolution:	0.1 °C 1 °F 0.1 bar 1 psi

20.3 DIGITAL INPUT

Type: (configurable via software parameter)	Free contact not opto-insulated
Number of inputs:	11
Notes: 	Don't supply voltage to the digital inputs in order to not cause damage to the instrument

20.4 ANALOGUE OUTPUTS

Type:	Non opto-insulated, internal power
Number of outputs:	4
Type of analogue output: (configurable via software parameter)	4 configurable outputs: - OUT1/OUT2: 0-10Vdc - OUT3 and OUT 3: <ul style="list-style-type: none"> • 0-10Vdc • PWM (to use with Dixell XV series fan controllers)
Maximum load:	40mA
Accuracy:	±2% full scale
Note: 	The electrical devices controlled by these analogue outputs must be powered separately with another transformer (do not use the same secondary of the controller's power) in order to prevent the outputs from malfunctioning or being damaged.

20.5 DIGITAL OUTPUTS

Type:	Relays with NO contacts
Number of outputs:	6: IC106CX model 8: IC108CX model
Maximum load:	5A(250Vac) SPST 5(2)A
Note: 	Verify maximum current of the loads and maximum current of the common line of the relay (10A max).

	<p>There is double insulation between the digital outputs and the low voltage of the rest of the circuit.</p> <p>Do not use different voltages for the two groups of relays.</p> <p>Some contactors can produce very high electrical stresses on the relay contacts mounted in the device.</p> <p>Dixell suggests to carefully check the technical documentation of the contactors and follow the instructions contained in this documentation (commercial documentation is not a reference for these information). To protect the relay contacts of the device, verify the need to use electrical disturbance suppressors or excess voltage protections</p>
--	--

<p>LUMITY</p> <p>EMERSON</p> <p>Dixell S.r.l. - Z.I. Via dell'Industria, 27 - 32016 Alpage (BL) ITALY Tel. +39.0437.9833 r.a. - Fax +39.0437.989313 - EmersonClimate.com/Dixell - dixell@emerson.com</p>
