

Bottle Cooler Solutions

Controllers for static, ventilated and open coolers





Bottle cooler controllers

The **XRB** series is the high efficiency range of products available in 2 versions, standard and advanced named XRB Enhanced. The family allows a low environmental impact, as it is ready to be used with natural refrigerant applications (R290, CO2, R600a, ...), and meets the needs of the highest performance coolers available on the market. The controllers have an attractive design and new innovative functions especially dedicated to energy saving.

Completely integrated control solution

Thanks to the high usability and completeness due to the easy-to-user interface and the wide range of functions dedicated to the bottle cooler optimization, the controllers are the ideal solution for the management of:

- STATIC COOLERS
- VENTILATED COOLERS
- OPEN OR NIGHT CURTAIN COOLERS



General functions



Extra cooling for filling

Designed for cabinet refill operations, this function uses automatic temperature management, which moves the set point to a lower value for a predefined period; in this way, the beverages can quickly reach the right selling temperature.

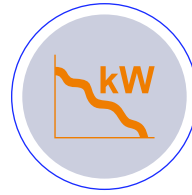

Energy saving

(only for XRB-CH Enhanced)

Thanks to an advanced and patented algorithm, the XRB series can automatically select the best temperature set by analyzing the temperature variation trends over a predefined interval of time. No external sensor is required for this operation.



Self regulation capability

(only for XRB-CH Enhanced)

The XRB family is able to choose the best suited set point and to decide the beginning and the duration of any defrosts based on the real using conditions and without external sensors.



Automatic defrost management

(only for XRB-CH Enhanced)

All standard defrost methods are supported in the XRB family. Moreover, defrost can also be managed automatically and its duration depends on the effective presence of ice on the evaporator surface.

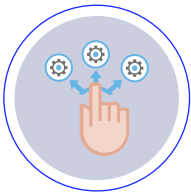

Multi map

(only for XRB-CH Enhanced)

Two different parameter maps are preloaded into the controller memory. The final user can select the one which better fits the final application and then quickly tune the parameters.

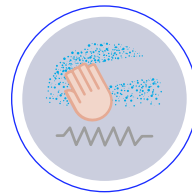

Anti-sweat heaters management

(only for XRB-CH Enhanced)

It is possible to manage heating elements by using an auxiliary relay output; this can be managed via an interval of time (fixed activation and deactivation) or by using an auxiliary temperature regulator.



Pull down time

(only for XRB-CH Enhanced)

It is possible to anticipate the end of an Energy Saving interval by using a specific parameter. In that way it is possible to guarantee that, at the beginning of any working interval, the bottles are at the right selling temperature.



Service & production

(only for XRB-CH Enhanced)

The XRB controllers include several functions designed to help the manufacture and the service personnel:

- compressor run hour counter;
- easy visualization of the number of activations for all relay outputs;
- quick and easy firmware updating;
- customization of the programming parameters, directly in production, by using WIZMATE PROG-TOOL KIT.



Proximity sensor

(only for XRB-CH Enhanced)

The X-MOD motion sensor is able to detect the presence of human beings without any physical contact. This allows the optimization of both the light switch-on and off, and the regulation temperature.

Applications

Depending on the kind of application, there are different controllers that ensure the highest standards of performance of the cooler.

Door cabinet - Static coolers



- Room probe
- Evaporator probe
- Compressor management
- Light management
- Timed defrost by compressor stop

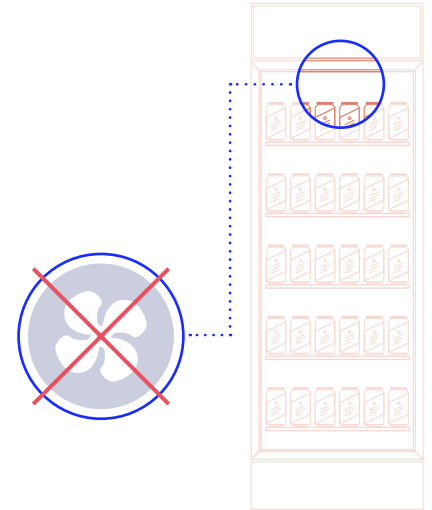

Open cabinet - With or without night curtain coolers

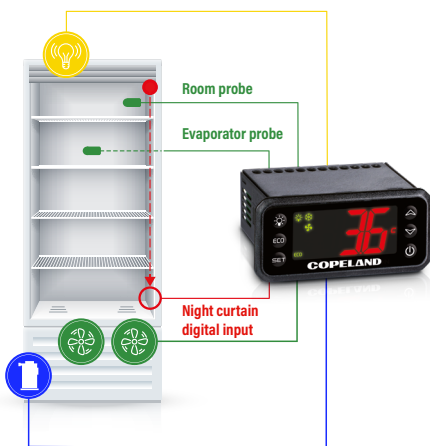

- Room probe
- Evaporator probe (optional) for heating elements, condenser temperature, and more
- Compressor management
- Light management
- Digital input for night curtain management
- Timed defrost by compressor stop

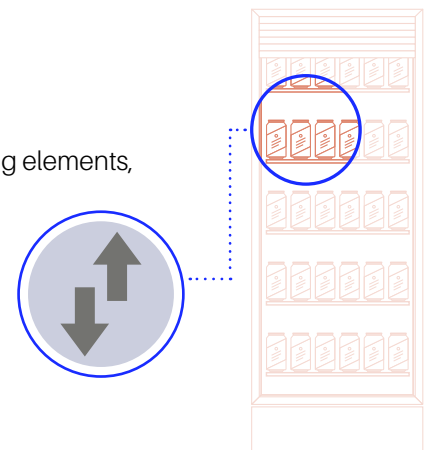

Door cabinet - Ventilated coolers

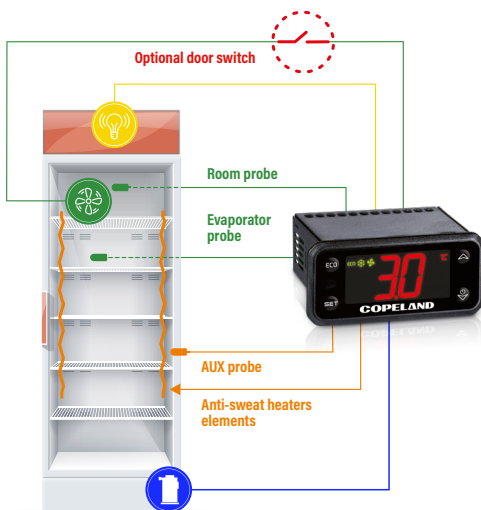

- Room probe
- Evaporator probe
- AUX probe
- Compressor management
- Fan management
- Light management
- Timed defrost by compressor stop
- Electric or hot gas defrost (if available)
- Anti-sweat heater management

Designed also for "STREET COOLER" applications thanks to the heating function

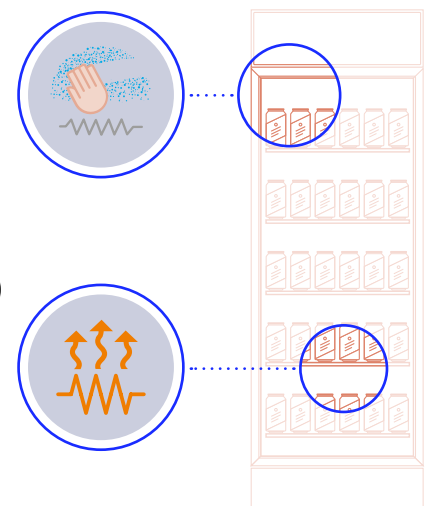

Useful for...

... OEM

- **High flexibility thanks to the different energy saving modes**

The XRB can adapt quickly and easily to any possible situation; the energy saving configuration, which fits the application, can be selected in only a few steps.

- **Reduced CO₂ emission** (only for XRB-CH Enhanced)

Thanks to the advanced algorithm, the XRB reduces power consumption and consequently carbon emissions.

- **High reliability** (only for XRB-CH Enhanced)

Loads (compressor, defrost, etc...) are activated only if necessary; this increases the equipment life and decreases the maintenance operations.

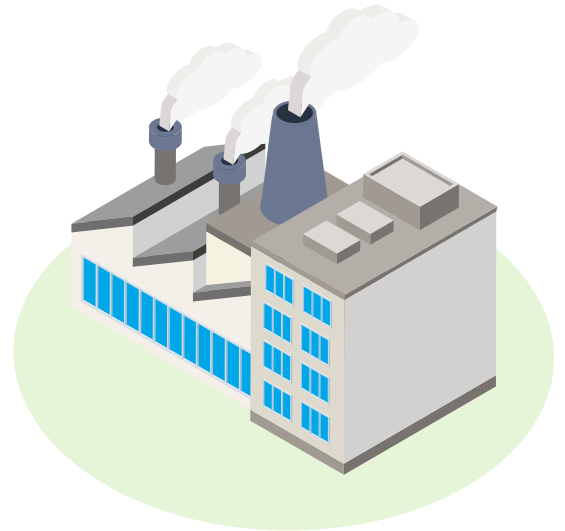

... end user

- **Few parameters to manage**

There is a really reduced set of parameters which need to be managed from the final user.

- **While replacing existing controllers, new functions can be introduced**

It is possible to introduce advanced energy saving concepts in existing cabinets with or without a door switch sensor.

- **Less programming time** (only for XRB-CH Enhanced)

Thanks to the self regulation capability, the XRB controllers adapt themselves to the temperature conditions and the kind of use.

Dimensions & cut-out

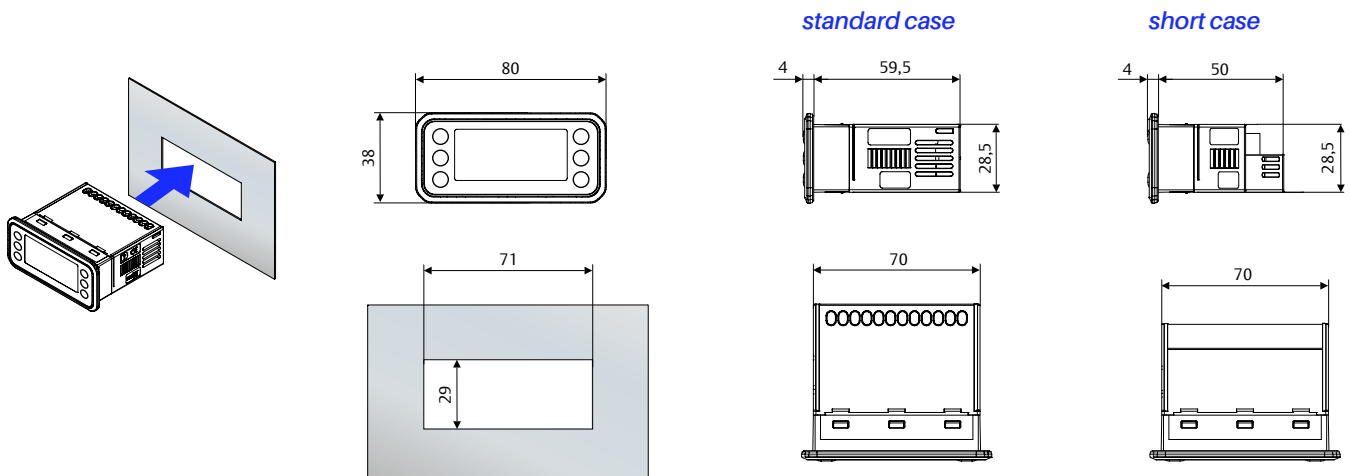

XRB-CH controllers



- 4 keys
- 2 digits large display with dedicated icons
- Available also in short version
- Dedicated key for energy saving activation/deactivation
- Red (standard) white and blue display
- Standard energy saving algorithms
- Condenser monitor for maintenance management

MODELS	XRB02CH	XRB03CH	XRB06CH	XRB07CH
Case	short	short	standard	standard
Display	± 2 d.p.	± 2 d.p.	± 2 d.p.	± 2 d.p.
Power supply	110, 230Vac	110, 230Vac	110, 230Vac	110, 230Vac
Probe inputs	up to 2 x NTC*	up to 2 x NTC*	up to 3 x NTC**	up to 3 x NTC**
Digital inputs	up to 1 x configurable	up to 1 x configurable	up to 2 x configurable	up to 2 x configurable
Relay outputs	20A	20A + 8A	16 + 8 + 8A 20 + 8 + 5A	16 + 8 + 8 + 5A
External port	HOT KEY	HOT KEY	HOT KEY	HOT KEY
Terminals	screw or plug-in	screw or plug-in	screw or plug-in	screw or plug-in
Buzzer	optional	optional	optional	optional

* Up to 2 NTC when the digital input is configured as probe

** Up to 3 NTC when the digital inputs are configured as probe

Main accessories



MDP/CX, MDP/E-CX

Plastic anti-condensing protection cover for terminal block.



HOT KEY

Key for a quick and easy parameter update.



USB type C connector available; please contact Copeland Controls S.r.l.



PROG KEY

(only for XRB-CH Enhanced)

Key for a quick and easy firmware update.

XRB-CH enhanced controllers



- 6 keys
- 3 digits large display with dedicated icons
- Dedicated key for energy saving activation/deactivation
- Red (standard) white and blue display
- Advanced energy saving algorithms (Patented)
- Automatic defrost management (Patented)
- Pull down time
- Antisweat heaters management
- Condenser monitor for maintenance management
- Multi map
- Real time clock
- Service counters (relay activation, working hours)
- Firmware update via special Prog key
- Modbus serial communication

MODELS	XRB30CH	XRB60CH	XRB70CH	XRB77CH
Case	standard	standard	standard	standard
Display	± 3 d.p.	± 3 d.p.	± 3 d.p.	± 3 d.p.
Power supply	110, 230Vac	110, 230Vac	110, 230Vac	12 Vac/dc, 110, 230Vac
Probe inputs	up to 4 x NTC*	up to 4 x NTC*	up to 4 x NTC*	up to 4 x NTC*
Digital inputs	up to 2 x configurable	up to 2 x configurable	up to 2 x configurable	up to 2 x configurable
Relay outputs	16 + 8A	16 + 8 + 8A 20 + 8 + 5A	16 + 8 + 8 + 5A	16+16+7+5A
External port	HOT KEY, TTL	HOT KEY, TTL	HOT KEY, TTL	HOT KEY
Serial output				RS485, 2 wires
Terminals	screw or plug-in	screw or plug-in	screw or plug-in	screw or plug-in
Buzzer	optional	optional	optional	optional
Real time clock	optional	optional	optional	optional

* Up to 4 NTC when the digital inputs are configured as probe



XJ485USB-KIT

(only for XRB-CH Enhanced)

USB to RS485 serial converter (2 wires) to interface any computer, equipped with Wizmate® software and a USB port, to a network of instruments.

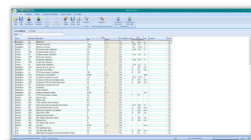

WIZMATE PROG-TOOL KIT

Programming tool for a quick and easy parameter update.



X-MOD

(only for XRB-CH Enhanced)

Motion sensor, with connection cable, able to detect the presence of human beings without any physical contact.



Copeland Controls S.r.l. | Z.I. Via dell'Industria, 27
32016 Alpago (BL) ITALY - dixell@copeland.com
Release 4.0 - 1582006010-GB

To learn more, visit [copeland.com](https://www.copeland.com)

©2024 Copeland LP

COPELAND
Engineered for Sustainability